

General Catalogue 2023/24

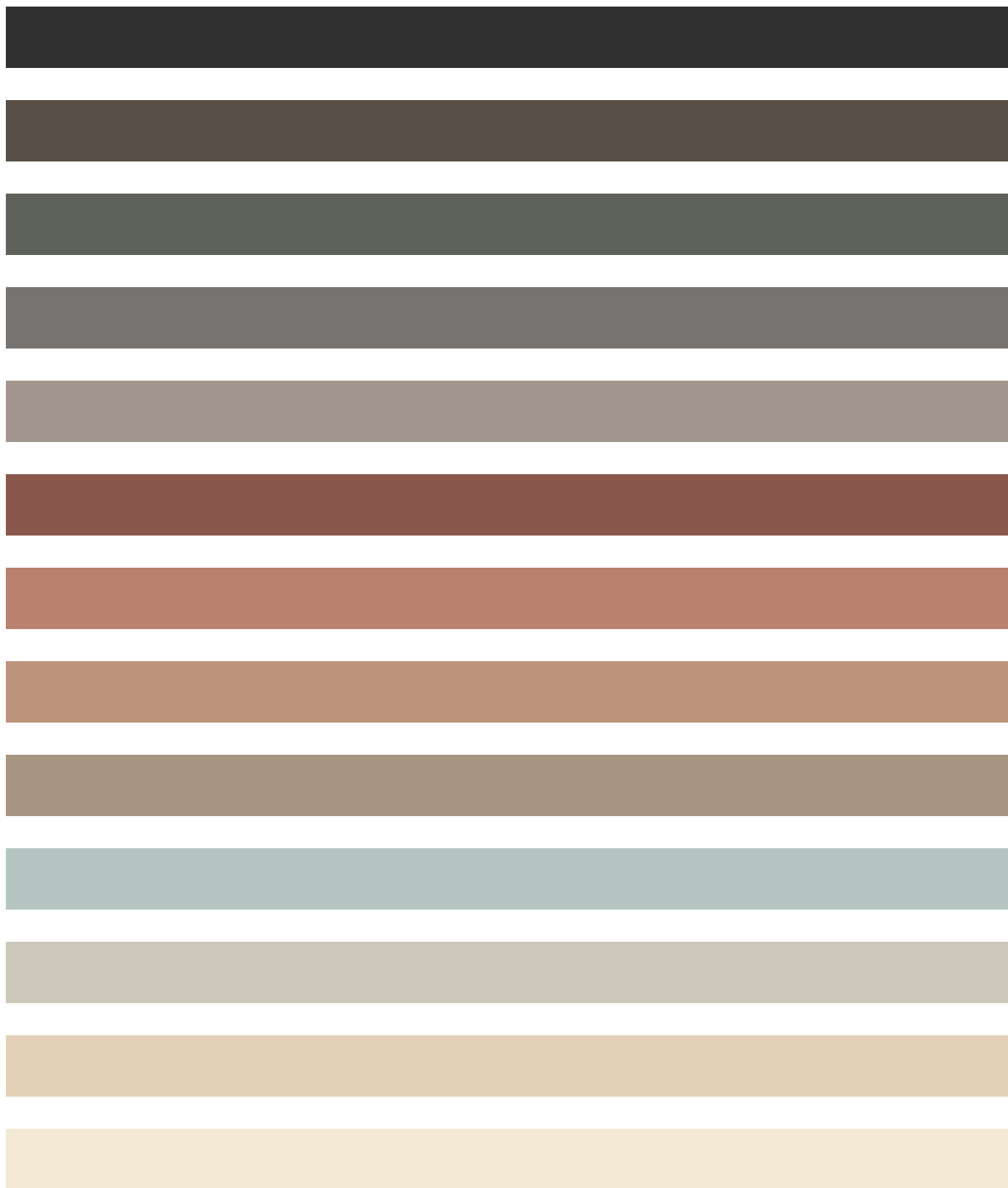

Micro.

ITA **Micro.** è un progetto.

Un progetto aperto e in continuo sviluppo che ricerca l'essenza, il minimo comun denominatore. Cerchiamo l'ergonomia, la sintesi, quella piccola cosa che può cambiare davvero la nostra vita in meglio. Hai presente? Un materiale più leggero e resistente, un rivestimento modellabile, non mettendo mai da parte la bellezza, la comodità e l'uso che ne farai. Collaboriamo con i migliori designer al mondo per portare avanti questo progetto perché ci piace sognare un futuro prossimo dove tutto quello che abbiamo intorno sia così.

ENG **Micro.** is an open project, a work in progress.

We search for the essence, the lowest common denominator. We search for ergonomics and synthesis, the little thing that can change our lives for the better. Do you know what we mean? A more lightweight and resistant material, a moldable coat, for example. Beauty, comfort and the use you're going to make of our products is our primary target. We work with the best designers in the world to carry out this project. We dream of a future where all you have around is better than ever.

ITA Il nostro cuore verde. Terratinta Group è impegnata ad integrare la sostenibilità nelle proprie attività d'impresa attraverso azioni concrete di miglioramento ambientale, sociale e di governance. L'azienda ha sviluppato un approccio strategico al tema a partire dal 2019 con il progetto CHANGE, per poi strutturare un percorso evolutivo che l'ha portata ad adottare la forma giuridica di Società Benefit (SB) e a definire un preciso set di obiettivi di miglioramento descritti nel nostro Report di Sostenibilità.

Dal 2020 l'azienda ha raggiunto il traguardo della Carbon Neutrality, compensando le emissioni climalteranti dirette ed indirette energetiche. Dopo un approfondito processo di analisi delle performance aziendali portato avanti nel corso degli ultimi 3 anni da parte di B Lab, Terratinta Group ha ottenuto la Certificazione B Corp. Le aziende B Corp sono realtà che si impegnano volontariamente a rispettare elevati standard di trasparenza e sostenibilità per migliorare e certificare il proprio impatto positivo verso l'ambiente, gli stakeholders, i lavoratori e la comunità per dare vita a un'economia più inclusiva e sostenibile. Terratinta Group vuole farsi portavoce di questo modo di fare impresa con un'attitudine positiva, con esempi concreti e piccole azioni quotidiane. L'impegno di Terratinta Group non si limita a generare profitto per l'azienda, ma aspira a perseguire il bene comune dei principali portatori di interesse dell'azienda stessa: i fornitori, i dipendenti, i clienti, la comunità. Infine, un tema cardine per Terratinta Group rimane sempre il welfare aziendale: un'attenzione particolare rivolta ai propri collaboratori e alla realizzazione di un equilibrio tra vita lavorativa e vita privata, coinvolgendo la squadra di lavoro in programmi di tutela della salute a riprova di un progetto che guarda al futuro.

ENG Our green heart. Terratinta Group is committed to integrating Sustainability approaches in its business activities through tangible actions of environmental, social and governance improvement. The company developed a strategic approach to the issue starting in 2019 with the CHANGE project and then built an evolution path that led it to adopt the legal form of a Benefit Company (SB) and to define a detailed set of improvement targets, described in our Sustainability Report. Since 2020, the company has also achieved Carbon Neutrality, compensating for direct and indirect energy greenhouse gas emissions.

After an in-depth process of corporate performance analysis carried out over the last three years by B Lab, Terratinta Group has obtained the B Corp Certification. B Corp companies are realities that voluntarily commit to comply with high standards of transparency and sustainability to improve and certify their positive impact on the environment, stakeholders, workers and the community to create a more inclusive and sustainable economy. Terratinta Group wants to be a spokesperson for this way of doing business with a positive attitude, concrete examples and small daily actions. Terratinta Group's commitment is not limited to generating profit for the company but aspires to pursue the common good of the company's main stakeholders: suppliers, employees, customers, and the community. Lastly, a pivotal theme for Terratinta Group always remains corporate welfare: a special focus on its employees and on achieving a work-life balance, involving the work team in health protection programs as proof of a project that looks to the future.

General Catalogue 2023

3D Forms Cross 010
Design Paolo Cappello e Simone Sabatti

3D Forms Fluted 018
Design D-Segno Studio

Typic 026
Design D-Segno Studio

Cluster 036
Design D-Segno Studio

Joint 052
Design Roberto Cicchinè

Familiar 064
Design Roberto Cicchinè

Perlinato 076
Design Roberto Cicchinè

Microtiles 090
Design Roberto Cicchinè / Giampaolo Benedini

Micropapers 134
Design Roberto Cicchinè

Micromosaics 148

3D Forms

Cross & Fluted collections

ITA 3D Forms raggruppa le nuove collezioni di piastrelle tridimensionali di Micro. Le prime due proposte sono “Cross” e “Fluted”, che permettono di giocare con la direzione della posa per creare una moltitudine di patterns in una ripetizione continua o in infinite combinazioni, consentendo di esprimersi con flessibilità e individualità. Una raccolta di proposte che celebra il movimento, i volumi e i colori, declinata nelle 13 tonalità cromatiche del progetto.

ENG 3D Forms bring together Micro.'s new three-dimensional tile collections. The first two proposals are ‘Cross’ and ‘Fluted’, which allow you to play with the direction of laying to create a multitude of patterns in a continuous repetition or infinite combinations, allowing for flexibility and individuality. A collection of designs celebrating movement, volume and colour, declined in the 13 colour shades of the project.

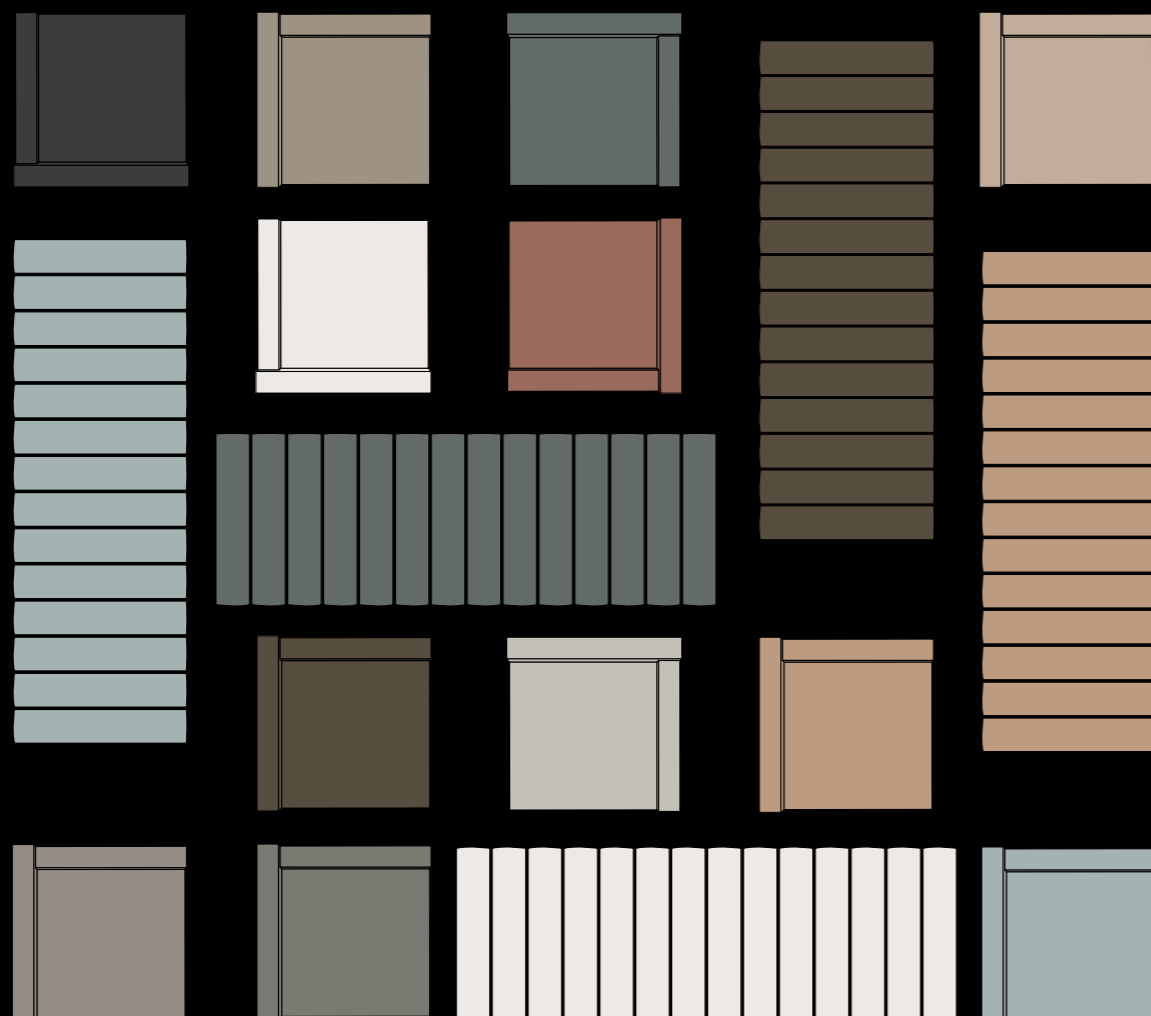

Cross handmade

Design
Paolo Cappello
Simone Sabatti

ITA Cross: una collezione di quadrati 10x10 in pasta bianca nei 13 colori Micro. che porta sulla superficie la contaminazione tridimensionale, trasformando la forma più tradizionale in un'esperienza sensoriale dove gli spessori diversi, i bordi e le ombre creano giochi geometrici in rilievo con combinazioni cromatiche quasi infinite.

ENG Cross: a collection of 10x10 white-body squares in the 13 Micro. colours that bring three-dimensional contamination to the surface, transforming the most traditional shape into a sensorial experience where different thicknesses, edges and shadows create geometric relief effects with almost infinite colour combinations.



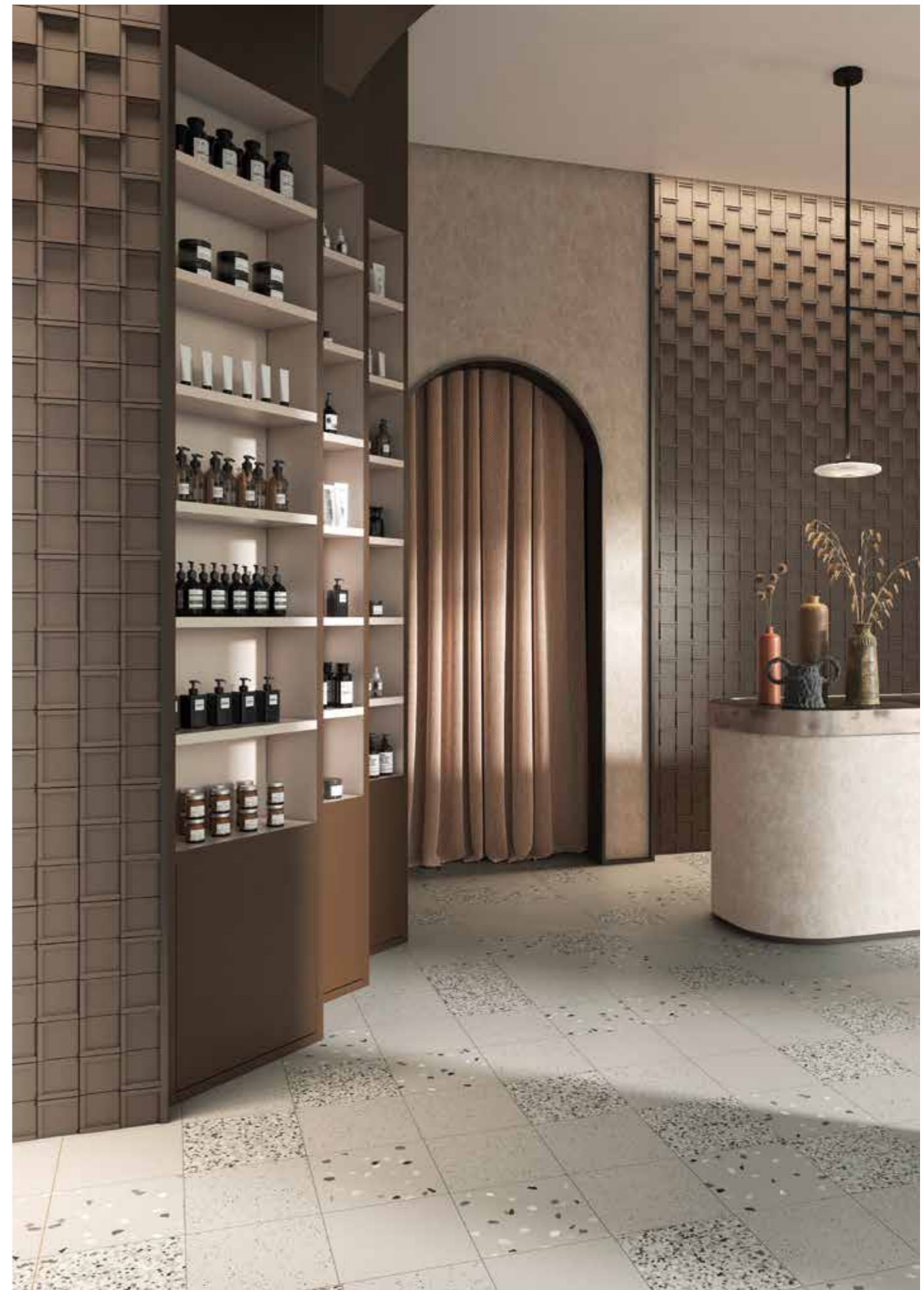



Cross handmade

10x10 cm / 4x4 inches

Design
Paolo Cappello
Simone Sabatti

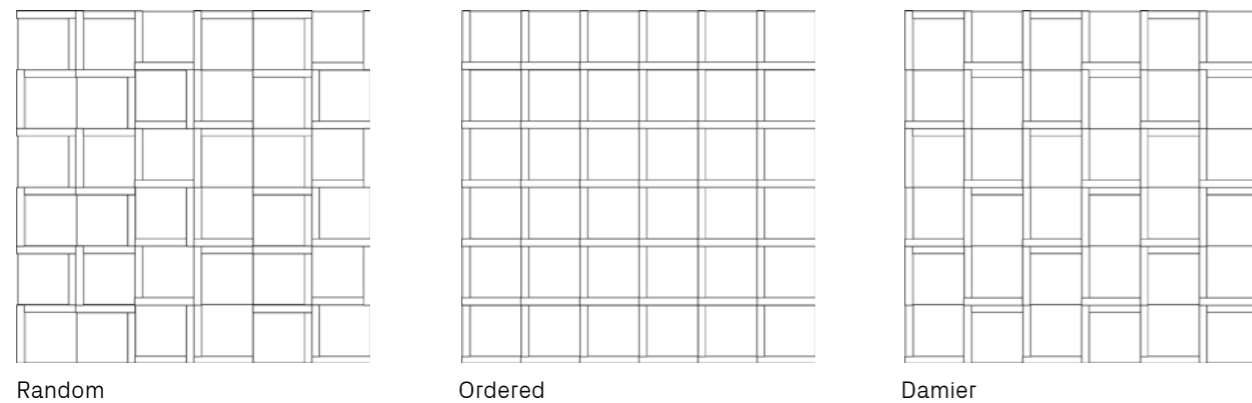
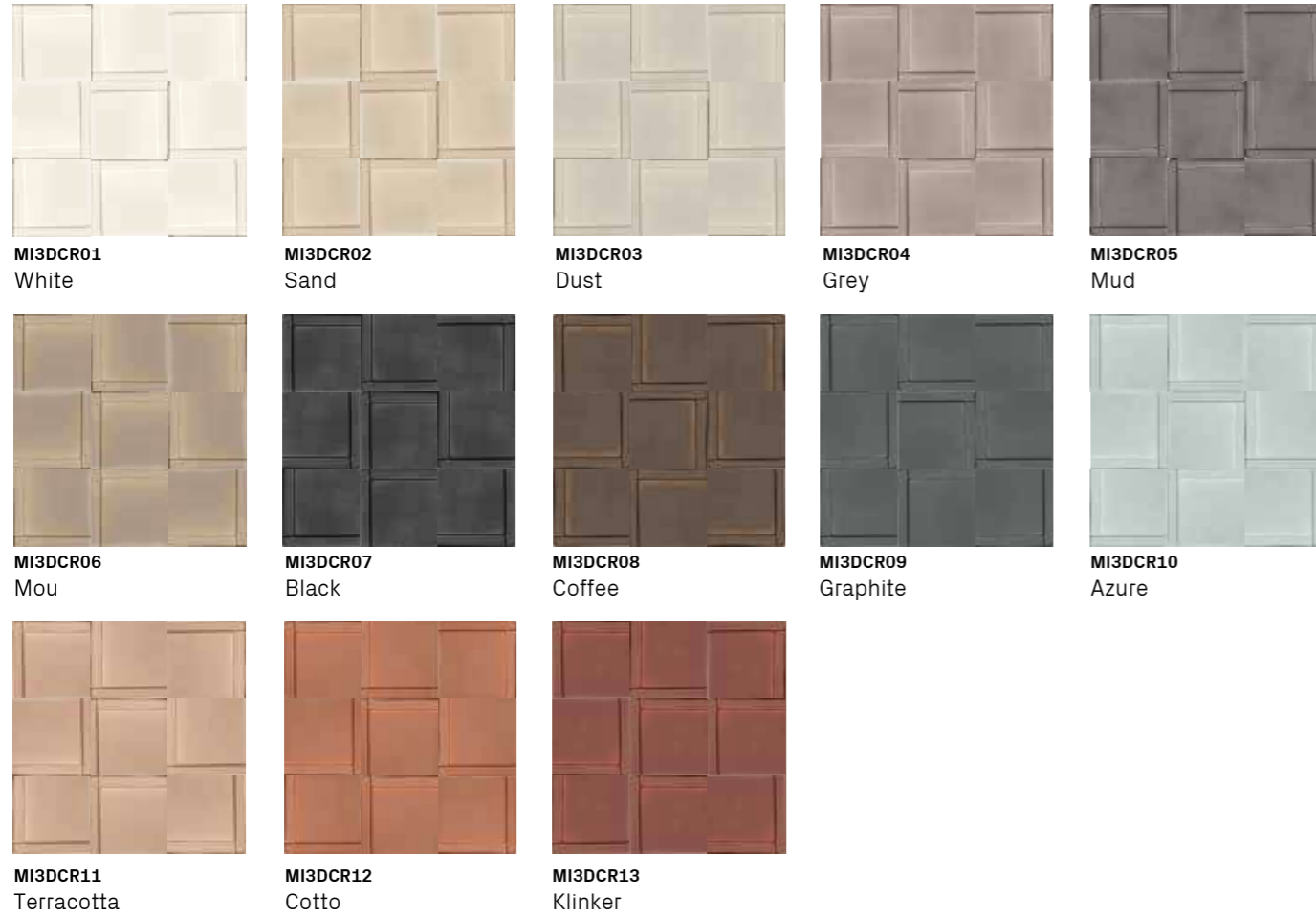
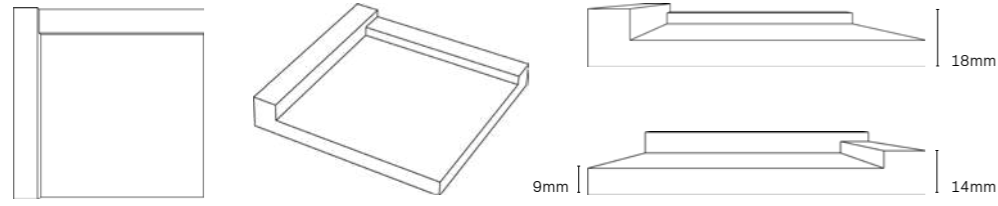

Cross handmade

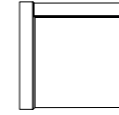

STUCCO
CONSIGLIATO
SUGGESTED
GROUT

MI3DCR01	White	102	
MI3DCR02	Sand	205	
MI3DCR03	Dust	110	
MI3DCR04	Grey	215	
MI3DCR05	Mud	120	
MI3DCR06	Mou	225	
MI3DCR07	Black	140	
MI3DCR08	Coffee	232	
MI3DCR09	Graphite	130	
MI3DCR10	Azure	105	
MI3DCR11	Terracotta	110	
MI3DCR12	Cotto	110	
MI3DCR13	Klinker	110	

Fluted

ITA Fluted è un elemento di design decorativo che accosta cromie e forme 3d. Una collezione di piastrelle in pasta bianca che dona al rivestimento la sua sinfonia di 13 colori avvolgenti che garantiscono continuità visiva.

ENG Fluted is a decorative design element that combines colours and 3D shapes. A collection of white-body tiles that gives the wall covering its symphony of 13 all-embracing colours that guarantee visual continuity.

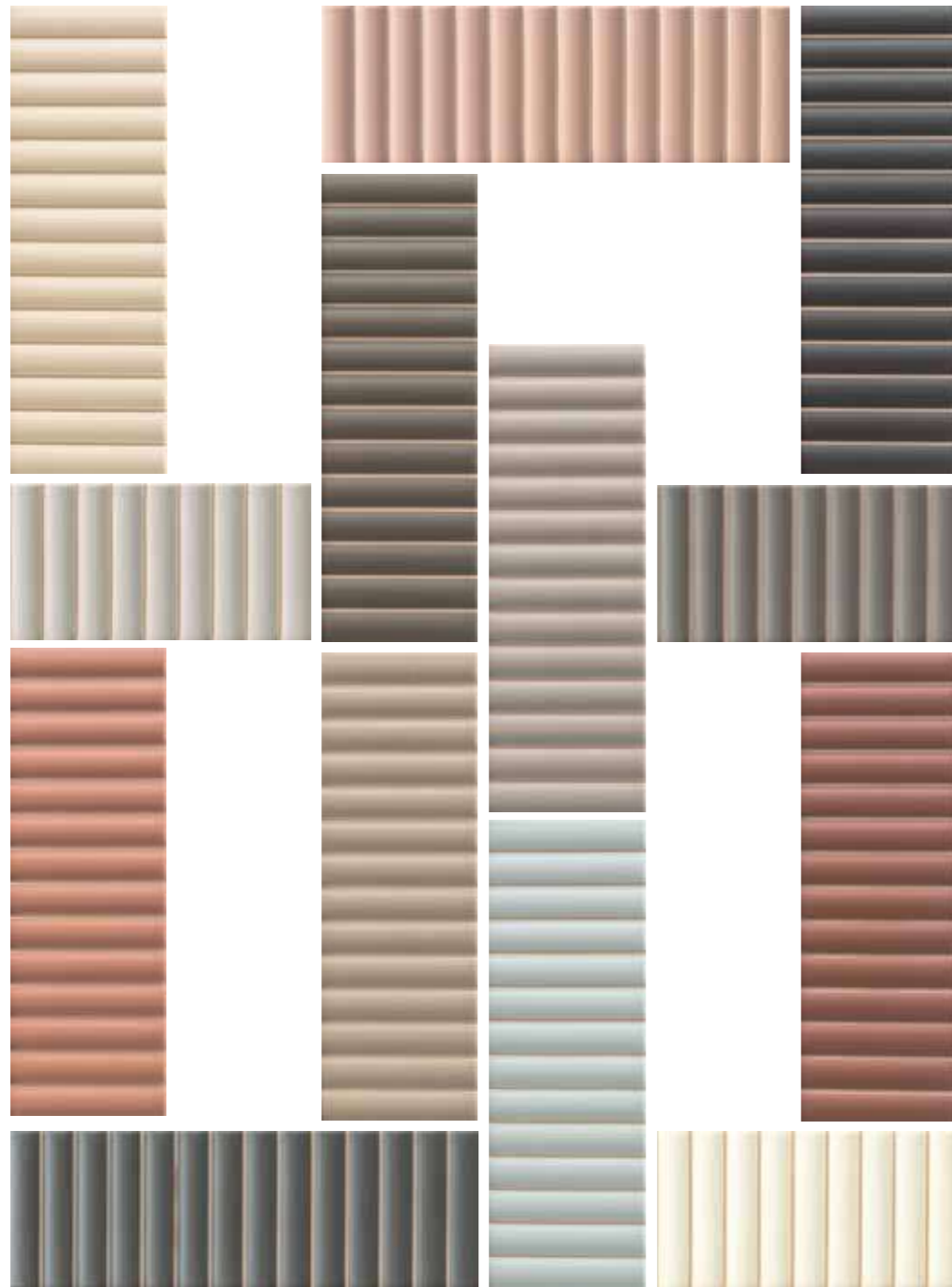

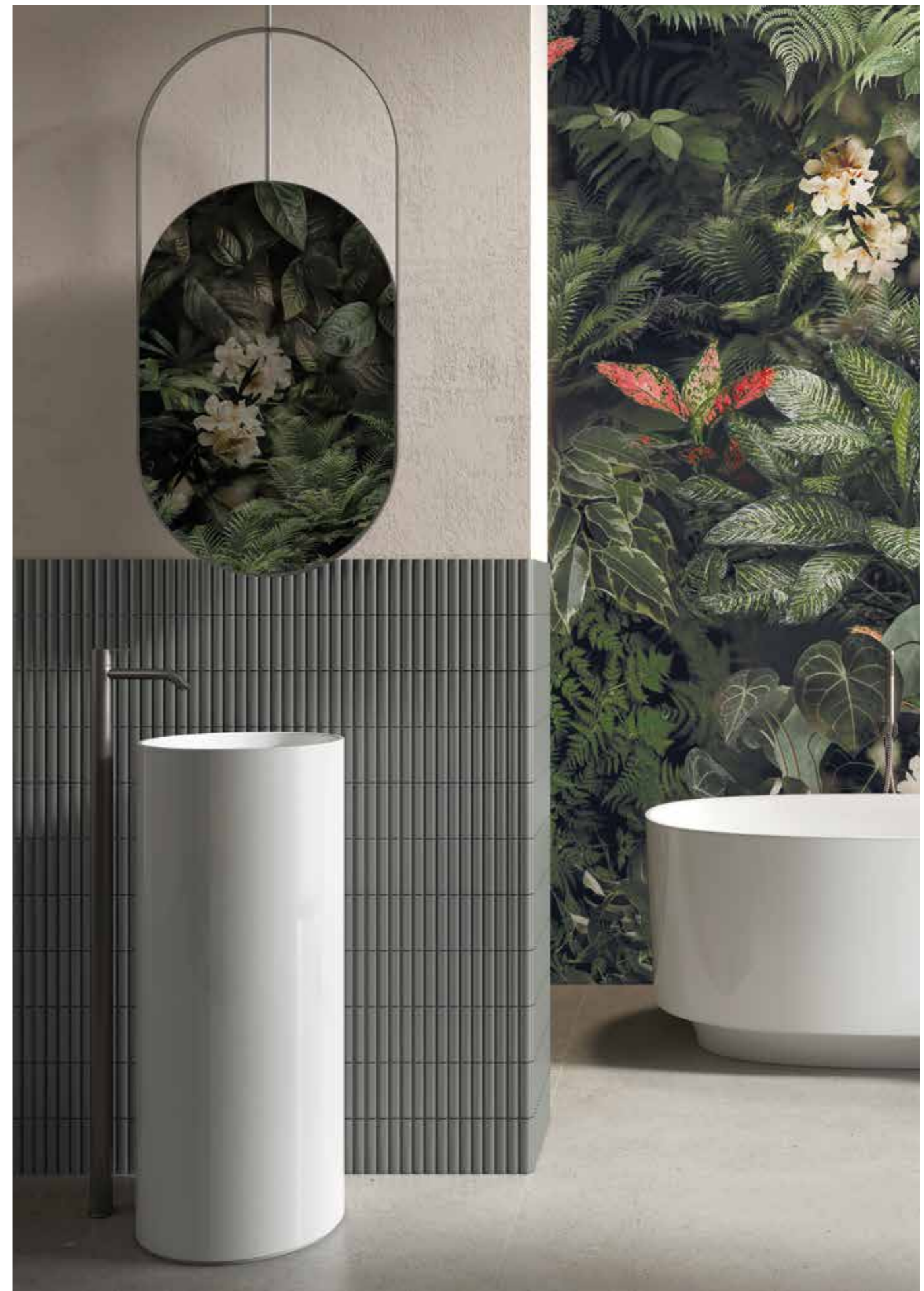



Fluted

10x30 cm / 4x12 inches

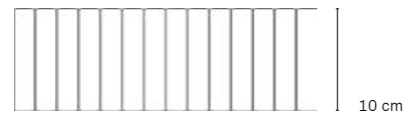

10 cm

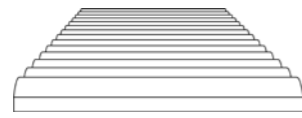

30 cm



MI3DFL01
White



MI3DFL02
Sand



MI3DFL03
Dust



MI3DFL04
Grey



MI3DFL05
Mud



MI3DFL06
Mou



MI3DFL07
Black



MI3DFL08
Coffee



MI3DFL09
Graphite



MI3DFL10
Azure



MI3DFL11
Terracotta



MI3DFL12
Cotto



MI3DFL13
klinker

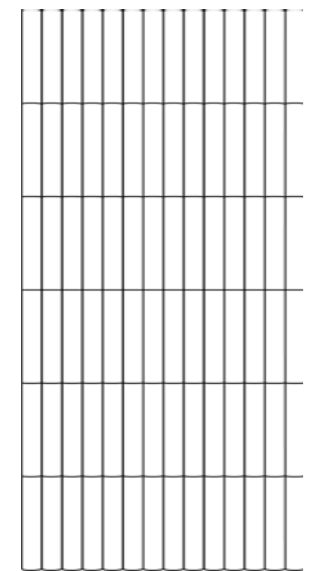

Vertical

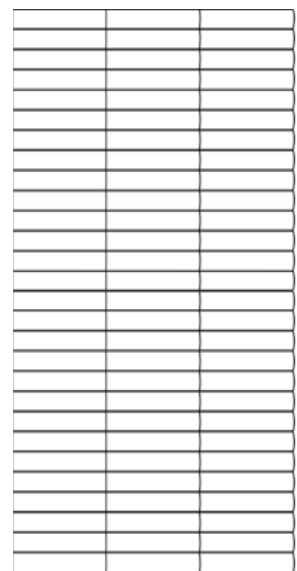

Vertical

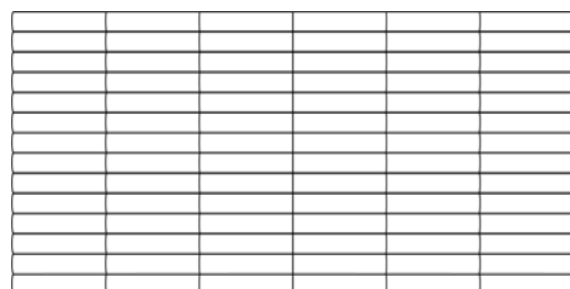

Horizontal

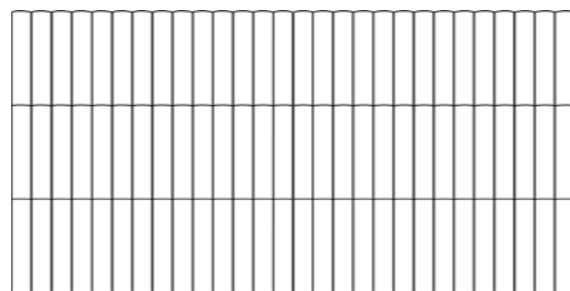

Horizontal

Fluted

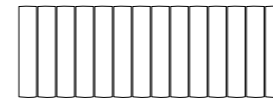

STUCCO
CONSIGLIATO
SUGGESTED
GROUT

MI3DFL01	White	102	
MI3DFL02	Sand	205	
MI3DFL03	Dust	110	
MI3DFL04	Grey	215	
MI3DFL05	Mud	120	
MI3DFL06	Mou	225	
MI3DFL07	Black	140	
MI3DFL08	Coffee	232	
MI3DFL09	Graphite	130	
MI3DFL10	Azure	105	
MI3DFL11	Terracotta	110	
MI3DFL12	Cotto	110	
MI3DFL13	Klinker	110	



Typic

Design
D-Segno Studio

ITA Typic è un progetto che trae ispirazione dal mondo dell'artigianato. Una superficie “perfettamente imperfetta” che combina vecchio e nuovo, tradizionale e sperimentale. Quadrati colorati compongono quinte a rivestimento che riflettono una nuova percezione degli spazi che abbiamo intorno: la parola d'ordine è flessibilità, le stanze diventano spazi programmabili per servire a molteplici scopi. Il risultato compositivo offre superfici colorate che esprimono atmosfere diverse creando molteplici combinazioni nei 13 toni cromatici del progetto.

ENG Typic is a project that draws inspiration from the world of craftsmanship. A “perfectly imperfect” surface that is the result of a montage of influences: old and new, traditional and experimental. Coloured squares make up wall panels that reflect a new perception of the surrounding space: the watchword is “flexibility”, the rooms become programmable spaces to serve multiple purposes. The compositional result offers coloured surfaces that express different atmospheres by creating multiple combinations in the 13 chromatic tones of the project.



Discover more
SCOPRI DI PIÙ





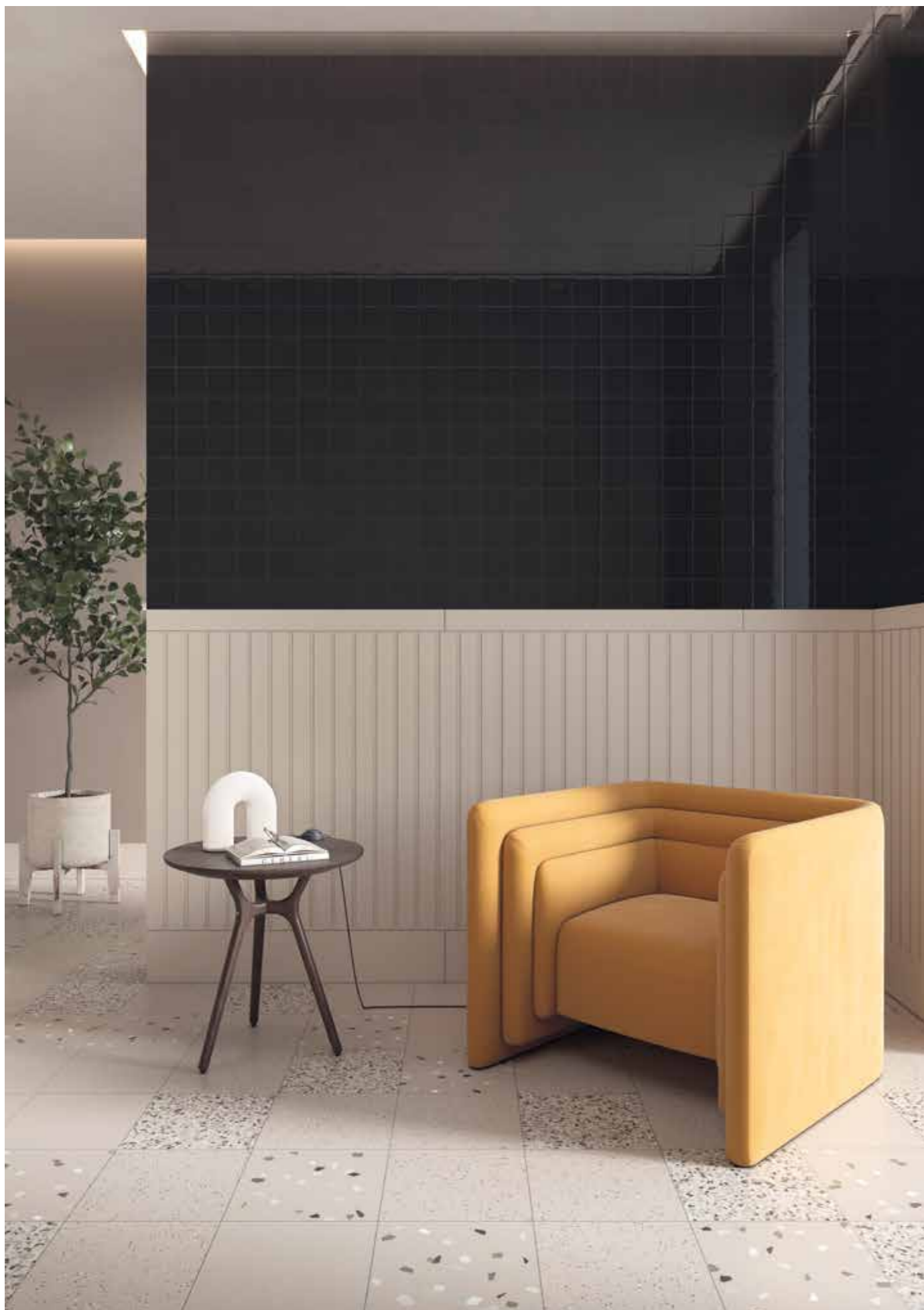

Typic

10x10 cm / 4x4 inches

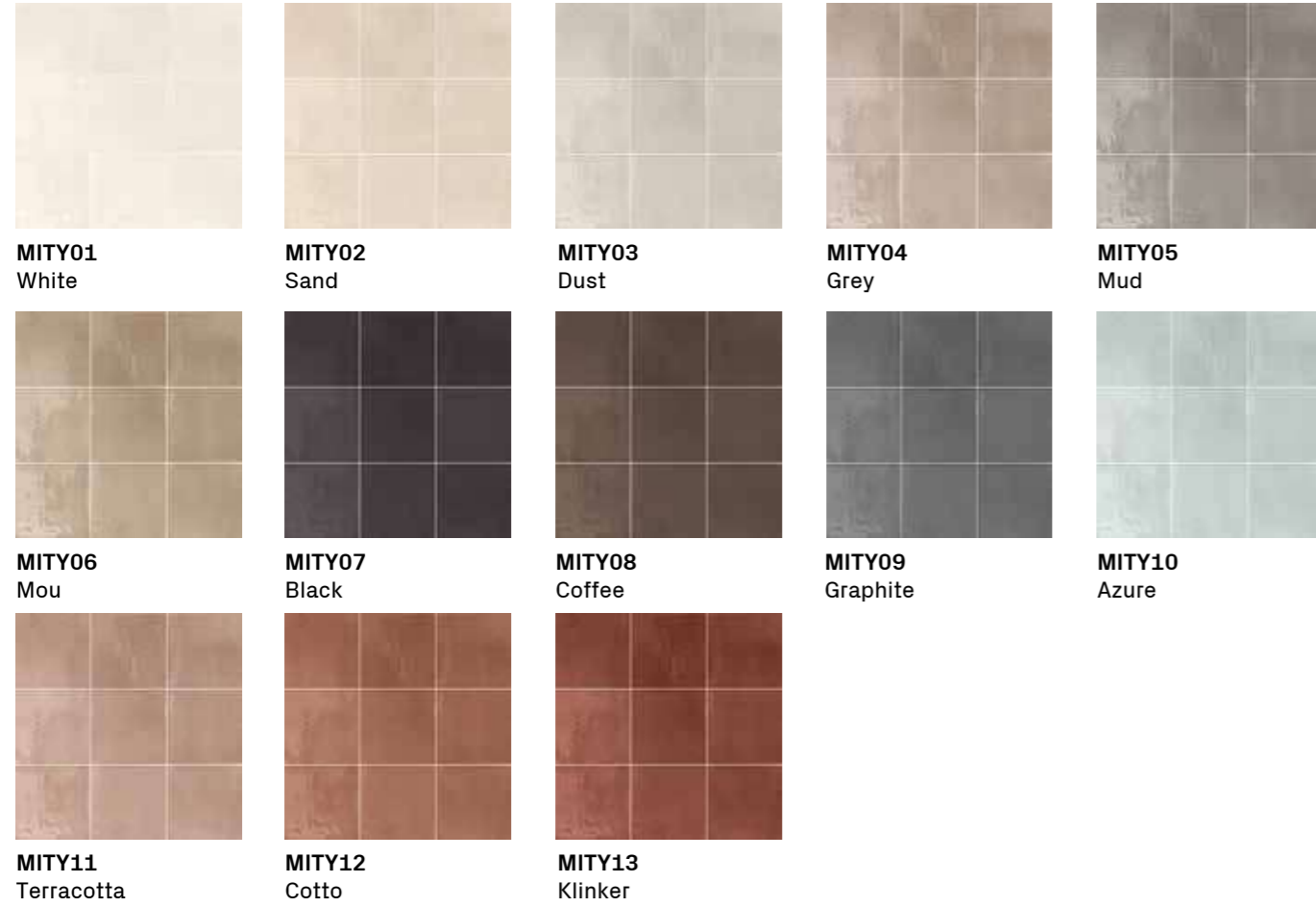

MITY01
White

MITY02
Sand

MITY03
Dust

MITY04
Grey

MITY05
Mud

MITY06
Mou

MITY07
Black

MITY08
Coffee

MITY09
Graphite

MITY10
Azure

MITY11
Terracotta

MITY12
Cotto

MITY13
Klinker

Typic

STUCCO
CONSIGLIATO
SUGGESTED
GROUT

MITY01	White	102	
MITY02	Sand	205	
MITY03	Dust	110	
MITY04	Grey	215	
MITY05	Mud	120	
MITY06	Mou	225	
MITY07	Black	140	
MITY08	Coffee	232	
MITY09	Graphite	130	
MITY10	Azure	105	
MITY11	Terracotta	110	
MITY12	Cotto	110	
MITY13	Klinker	110	

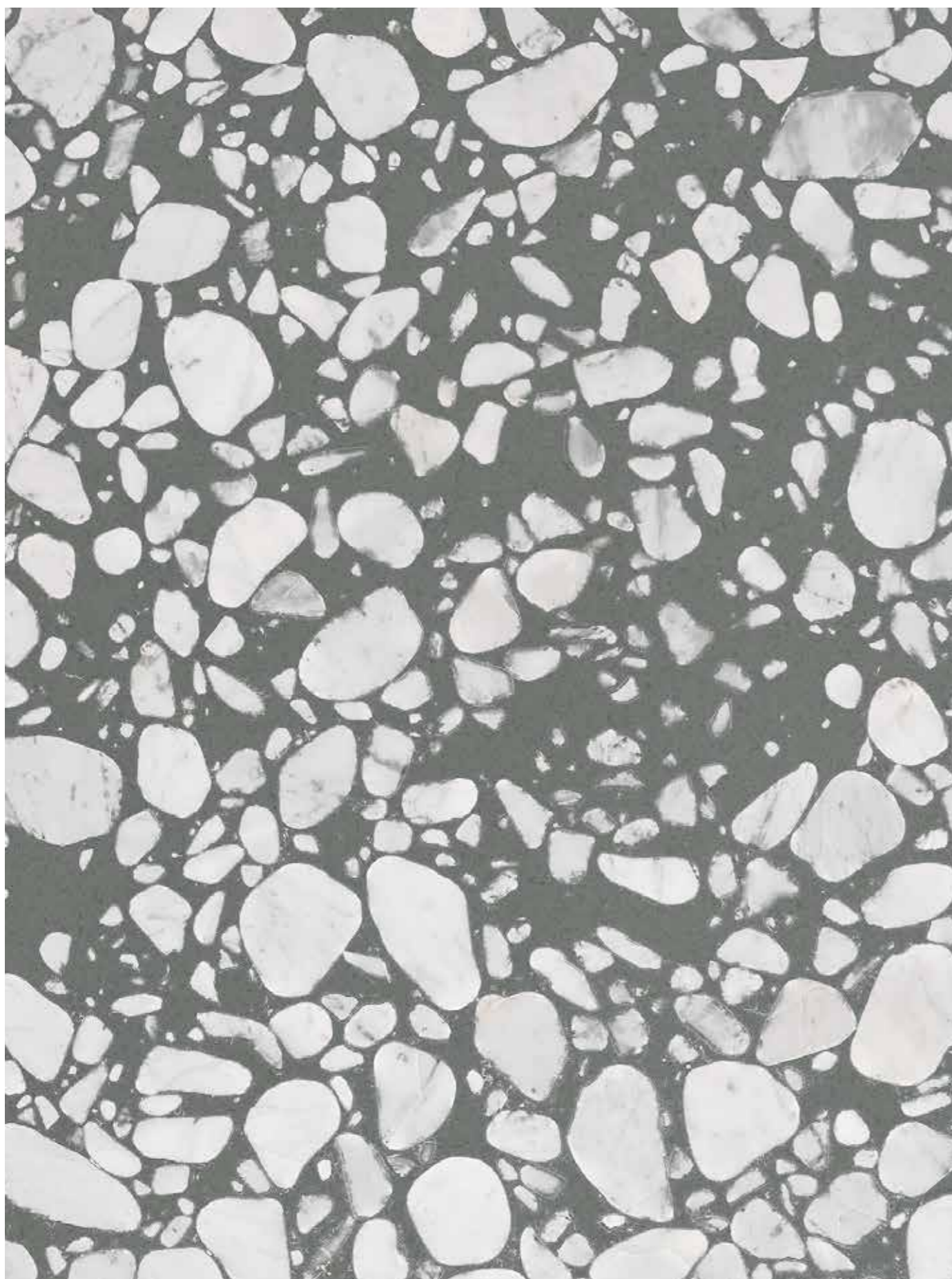

Cluster

Design
D-Segno Studio

ITA Cluster nasce ispirandosi alla palladiana veneziana tradizionale formata da scaglie di marmi pregiati, tra cui il Marmo di Carrara. Un prodotto che rientra tra i macro trends che stanno vivendo un'onda lunga: il terrazzo. Innovativo è sicuramente l'aspetto grafico, con le tessere solitamente "spigolose" che si fanno più organiche, diventano ciottoli che vanno a posizionarsi in maniera casuale sulla base conferendogli un'estetica più contemporanea. La collezione si sviluppa in 120x120 e 60x120 e in quattro toni cromatici abbinabili ai 13 colori del progetto Micro, che esplorano la gamma dei neutri partendo dal bianco per arrivare fino al Graphite.

ENG Cluster is inspired by the traditional Venetian Palladiana made of chips of precious marble, including the Carrara Marble. A product that is part of those macro trends that are experiencing a long wave: the terrazzo. The graphic aspect is certainly innovative with the usually "angular" tesserae that are now more organic, becoming pebbles that are randomly placed on the base, giving it a more contemporary look. The collection is developed in sizes 120x120 and 60x120 and in four colour tones that can be matched with the 13 colours of the Micro project which explores the range of neutrals starting from White to reach Graphite.



Discover more
SCOPRI DI PIÙ







Cluster White

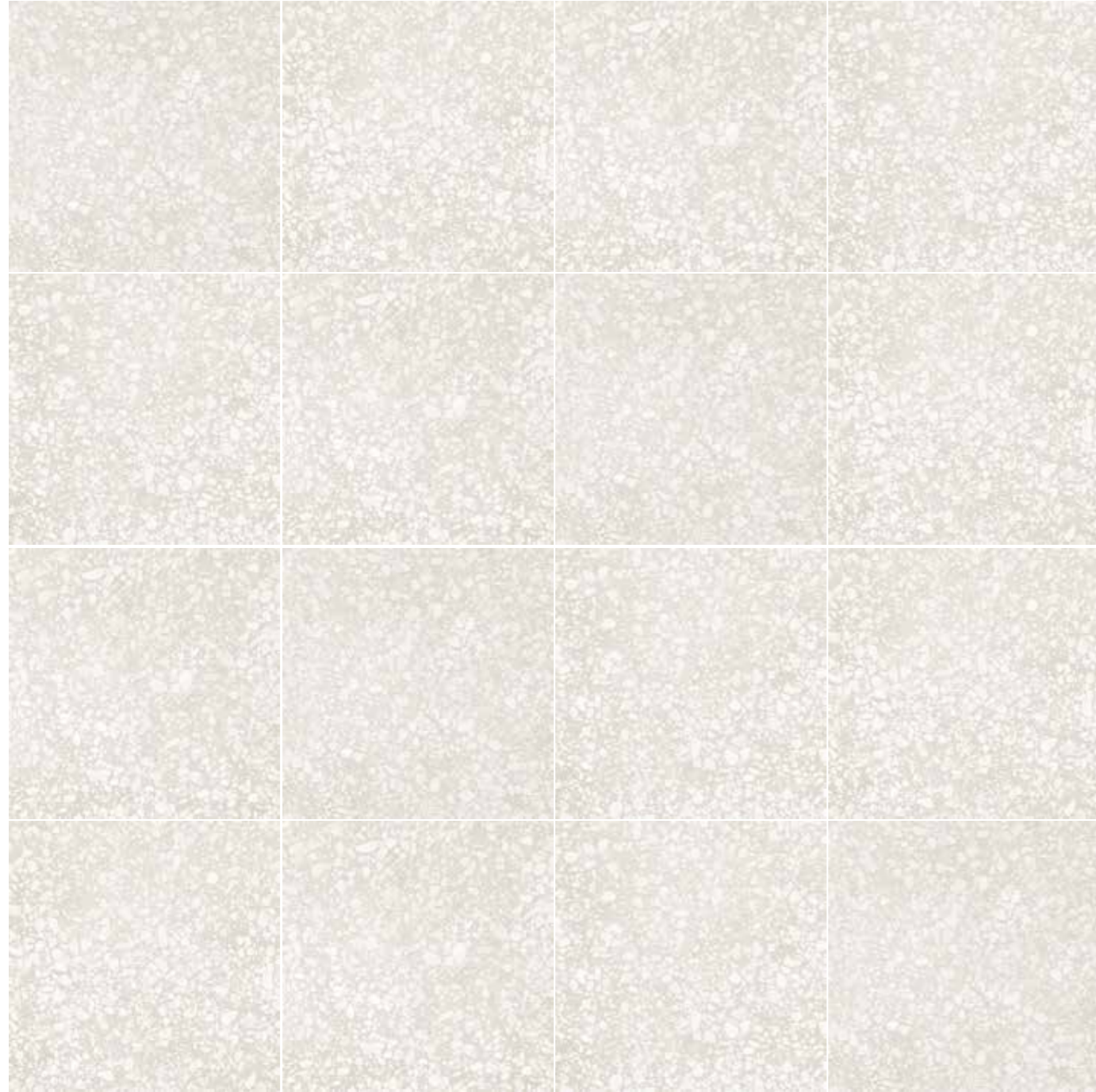

120x120 **MICLU01120N**
White

STUCCO
CONSIGLIATO
SUGGESTED
GROUT

210

Cluster

120x120 cm / 48x48 inches
60x120 cm / 24x48 inches
rettificato / rectified



120X120 **MICLU01120N**
White



60X120 **MICLU01612N**
White

Cluster Dust

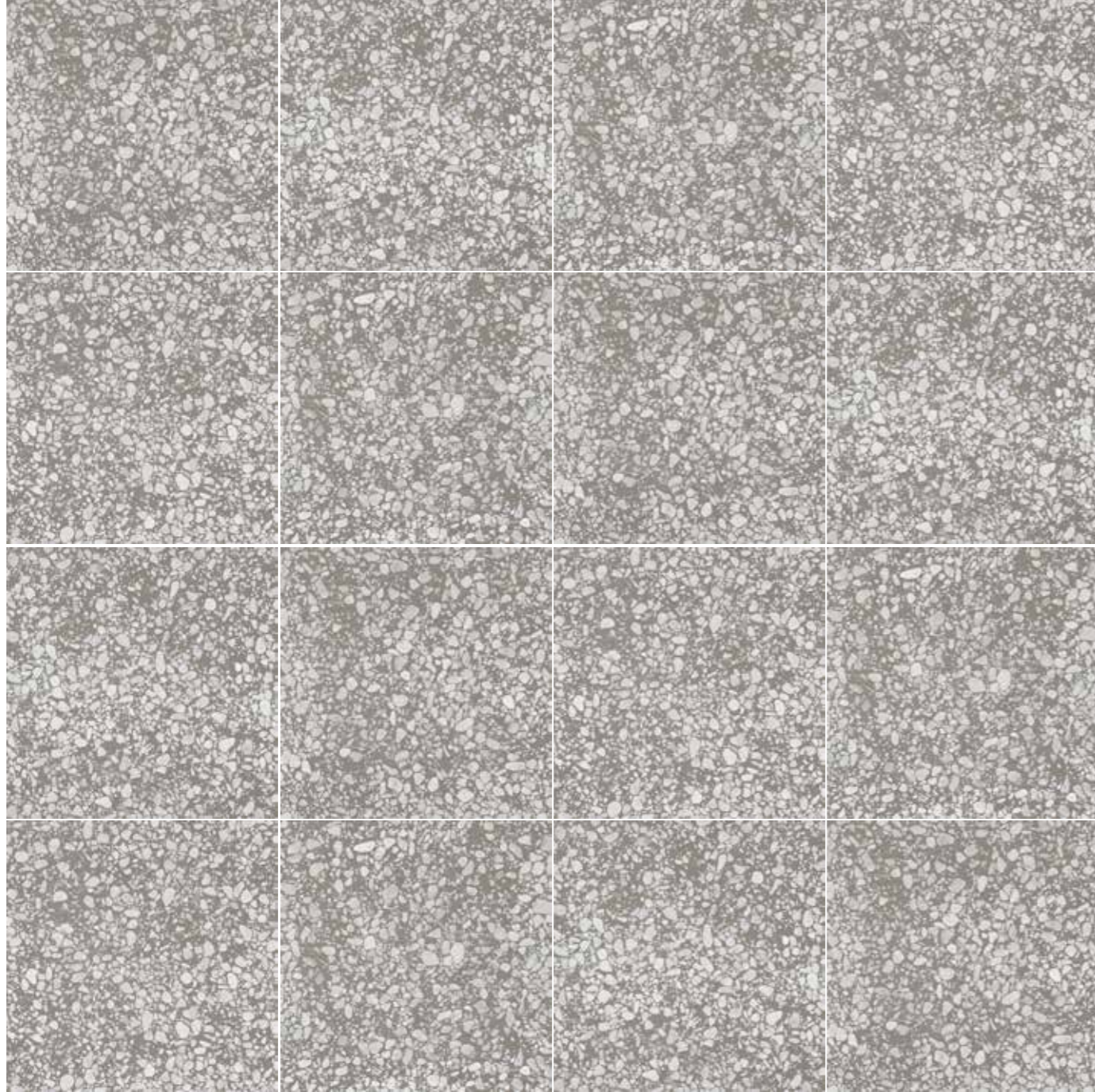

120x120 **MICLU03120N**
Dust

STUCCO
CONSIGLIATO
SUGGESTED
GROUT

215

Cluster

120x120 cm / 48x48 inches
60x120 cm / 24x48 inches
rettificato / rectified

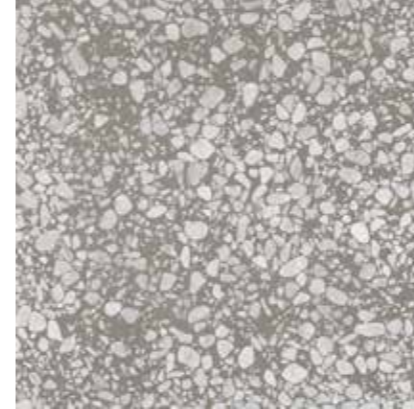

120x120 **MICLU03120N**
Dust



60x120 **MICLU03612N**
Dust

Cluster Cotto

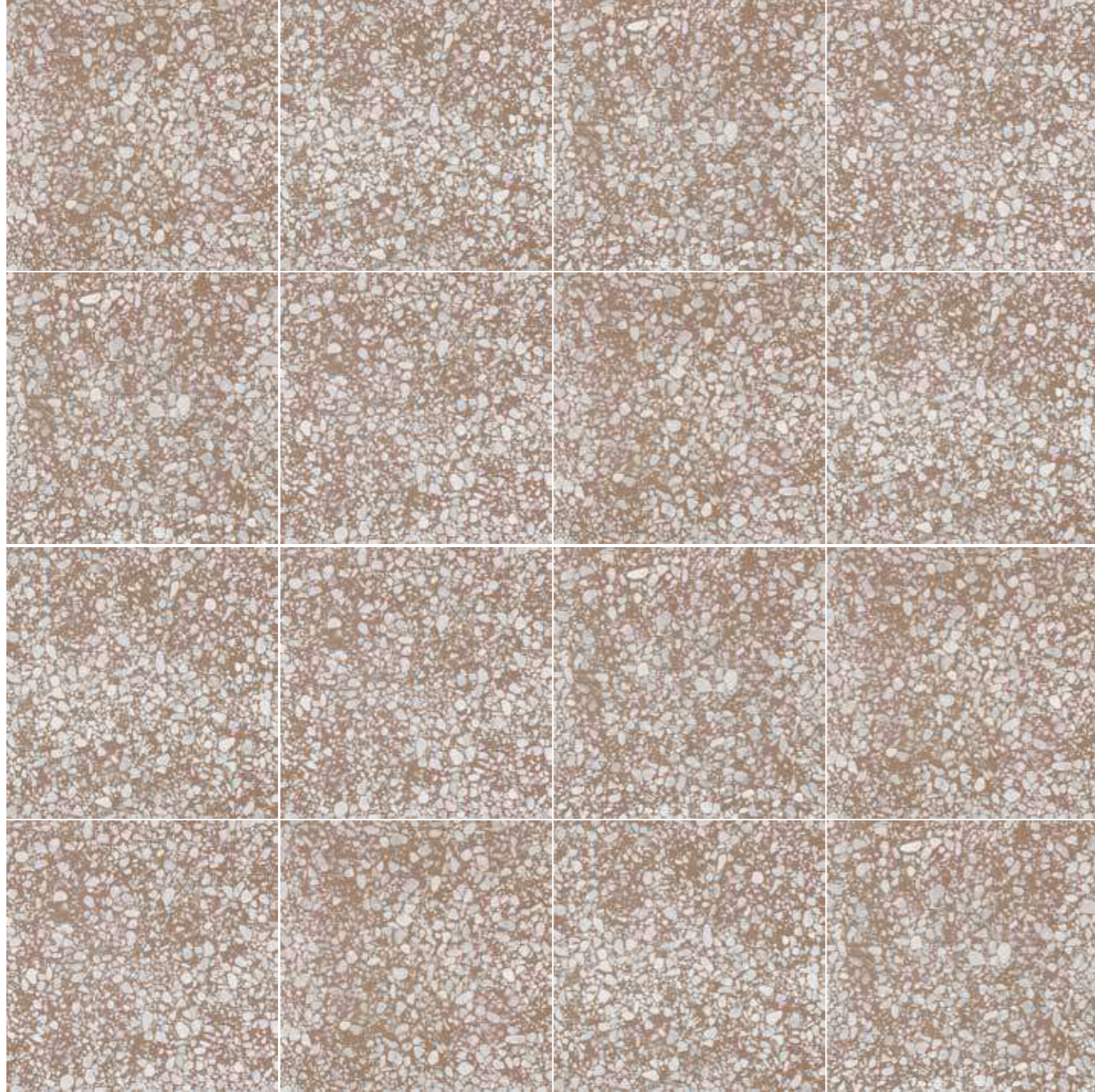

120x120 **MICLU12120N**
Cotto

STUCCO
CONSIGLIATO
SUGGESTED
GROUT

110

Cluster

120x120 cm / 48x48 inches
60x120 cm / 24x48 inches
rettificato / rectified

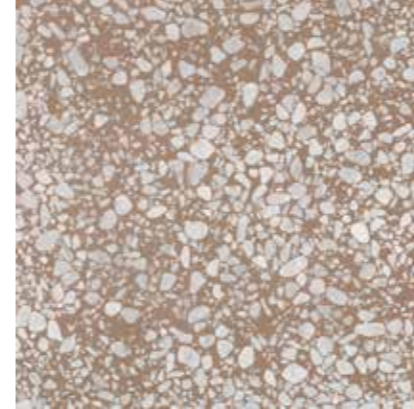

120x120 **MICLU12120N**
Cotto

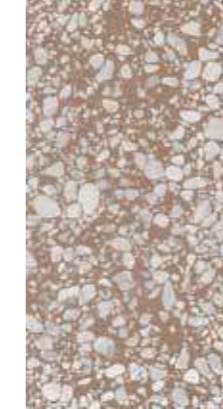

60x120 **MICLU12612N**
Cotto

Cluster Graphite

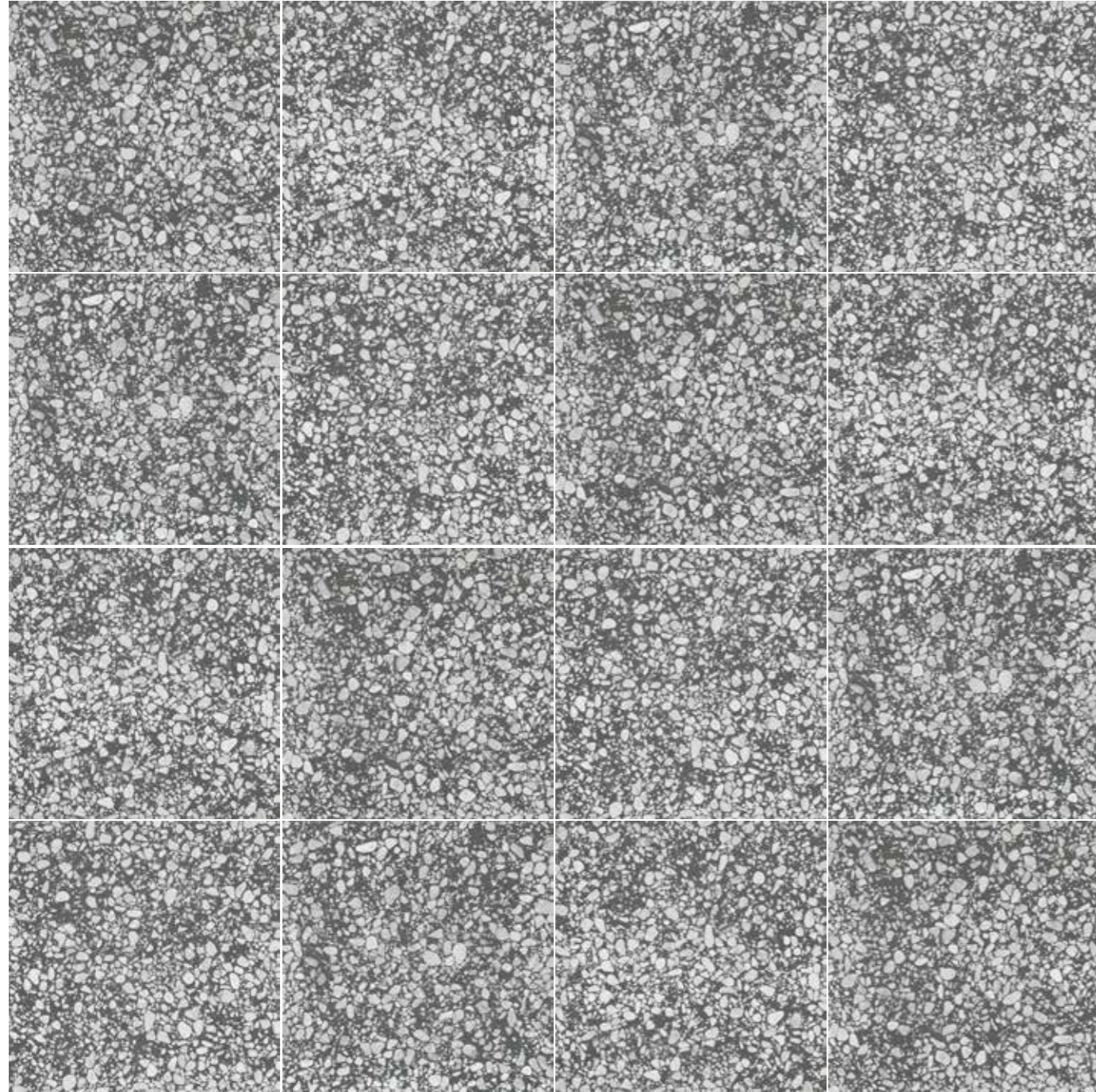

120x120 **MICLU09120N**
Graphite

STUCCO
CONSIGLIATO
SUGGESTED
GROUT

125

Cluster

120x120 cm / 48x48 inches
60x120 cm / 24x48 inches
rettificato / rectified

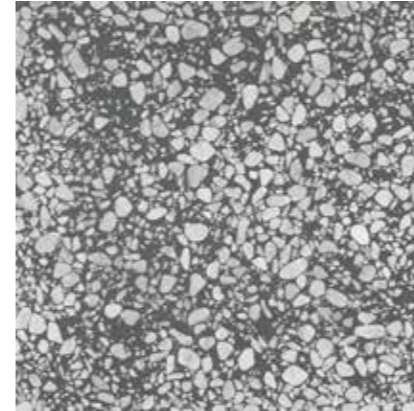

120x120 **MICLU09120N**
Graphite

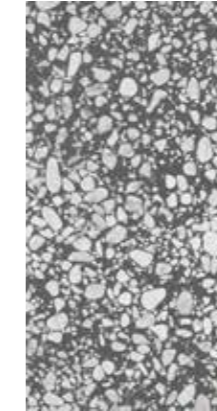

60x120 **MICLU09612N**
Graphite



Joint

Design
Roberto Cicchinè

ITA Un listello rettangolare in grès nei 13 colori Micro. disegna, attraverso molteplici schemi di posa, pavimentazioni e rivestimenti. Utilizzato nei mix cromatici oppure nelle tinte unite, Joint crea atmosfere differenti che si adattano ai vari stili ed ambienti dell'abitare. Uno studio accurato sulle fughe e l'utilizzo di stucchi dai colori abbinabili crea un'ulteriore opportunità estetica che acquista quel sapore senza tempo caro alle collezioni Micro.

ENG A porcelain stoneware rectangular listel in the 13 Micro. colours, designs floor and wall coverings through a variety of laying patterns. Used in chromatic mixes rather than solid colours, Joint creates different atmospheres that adapt to the various living styles and environments. A careful study of the joints and the use of sealant in matching colours creates an additional aesthetic opportunity that acquires that timeless flavour so dear to the Micro collections.



Discover more
SCOPRI DI PIÙ







Joint

7x28 cm / 3x11 inches



STUCCO
CONSIGLIATO
SUGGESTED
GROUT

MIJNT01	Joint White	102	
MIJNT02	Joint Sand	205	
MIJNT03	Joint Dust	110	
MIJNT04	Joint Grey	215	
MIJNT05	Joint Mud	120	
MIJNT06	Joint Mou	225	
MIJNT07	Joint Black	140	
MIJNT08	Joint Coffee	232	
MIJNT09	Joint Graphite	130	
MIJNT10	Joint Azure	105	
MIJNT11	Joint Terracotta	110	
MIJNT12	Joint Cotto	110	
MIJNT13	Joint Klinker	110	

Joint Mix

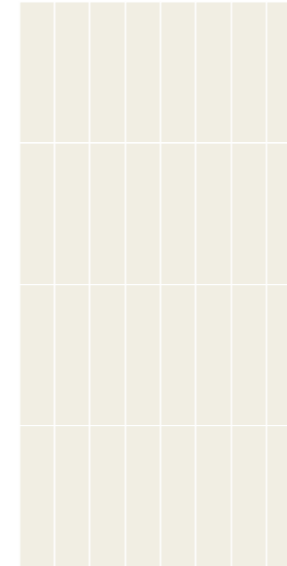

MIJNT01
Joint White
Colors. White 100%

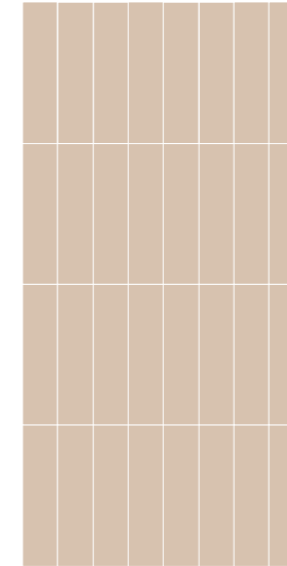

MIJNT11
Joint Terracotta
Colors. Terracotta 100%

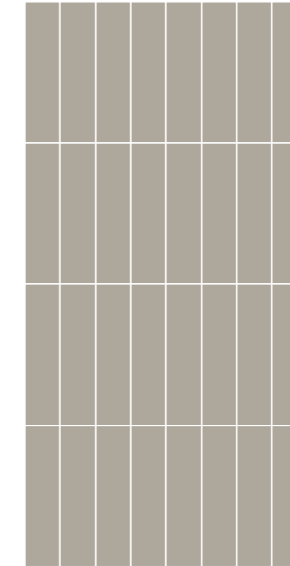

MIJNT04
Joint Grey
Colors. Grey 100%

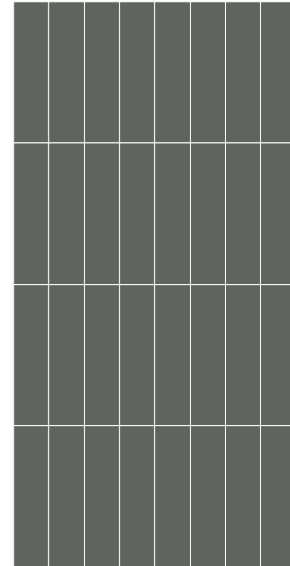

MIJNT09
Joint Graphite
Colors. Graphite 100%

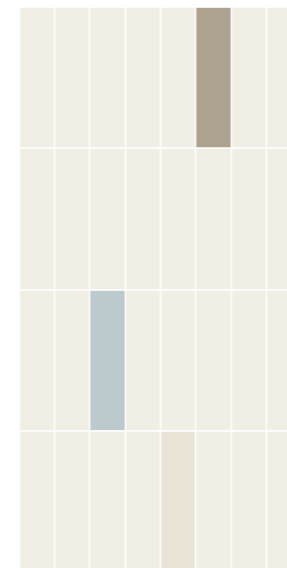

MIJNTMXL01
Joint White Light Mix
Colors. White 91%
Sand 3%
Mou 3%
Azure 3%

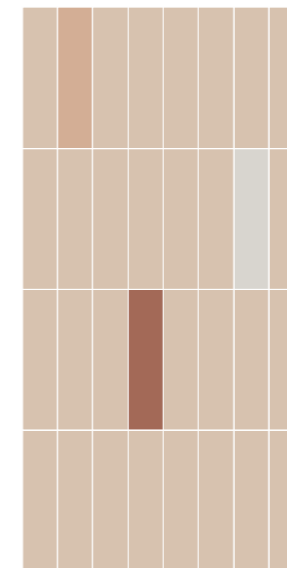

MIJNTMXL11
Joint Terracotta Light Mix
Colors. Terracotta 91%
Dust 3%
Cotto 3%
Klinker 3%

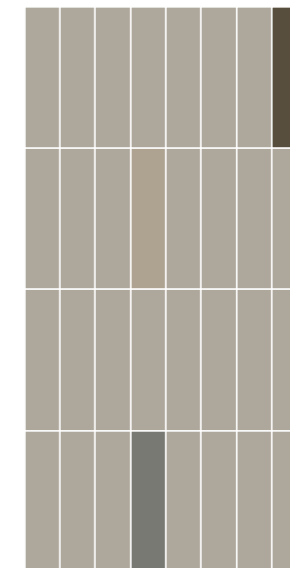

MIJNTMXL04
Joint Grey Light Mix
Colors. Grey 91%
Mud 3%
Cotto 3%
Coffee 3%

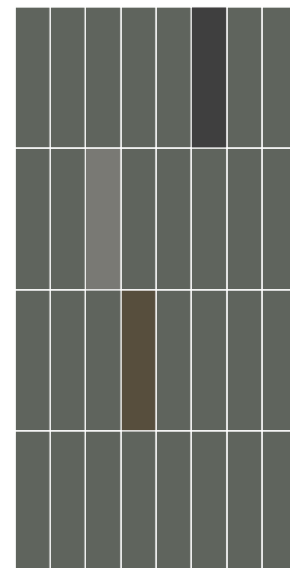

MIJNTMXL09
Joint Graphite Light Mix
Colors. Graphite 91%
Grey 3%
Black 3%
Coffee 3%

Joint Mix

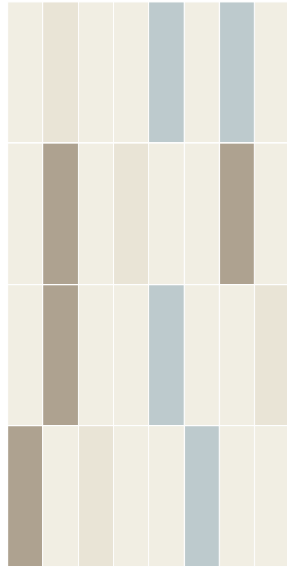

MIJNTMXM01
Joint White Medium Mix
Colors. White 61,5%
Sand 12,5%
Mou 12,5%
Azure 12,5%

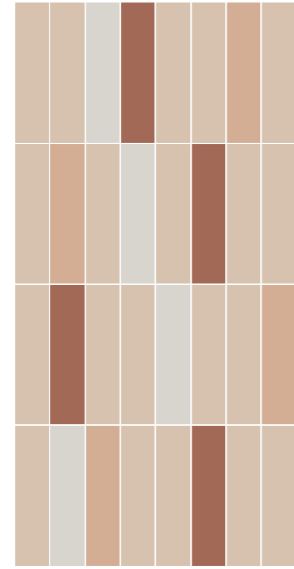

MIJNTMXM11
Joint Terracotta Medium Mix
Colors. Terracotta 61,5%
Dust 12,5%
Cotto 12,5%
Klinker 12,5%

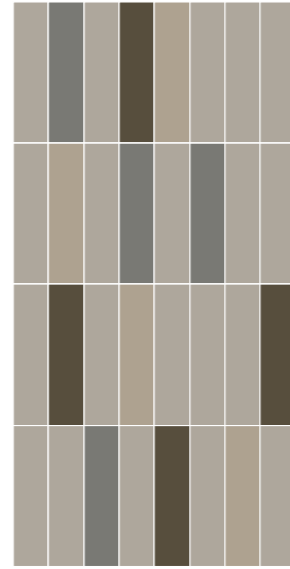

MIJNTMXM04
Joint Grey Medium Mix
Colors. Grey 61,5%
Mud 12,5%
Mou 12,5%
Coffee 12,5%

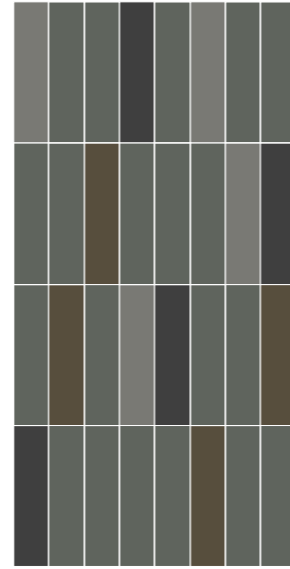

MIJNTMXM09
Joint Graphite Medium Mix
Colors. Graphite 61,5%
Grey 12,5%
Black 12,5%
Coffee 12,5%

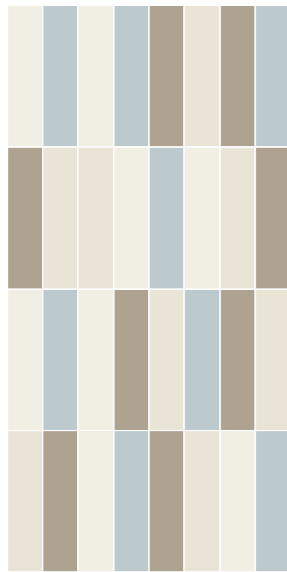

MIJNTMXS01
Joint White Strong Mix
Colors. White 25%
Sand 25%
Mou 25%
Azure 25%

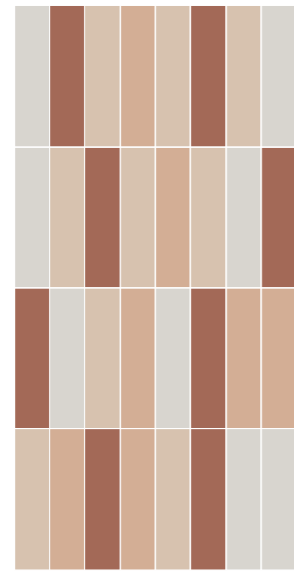

MIJNTMXS11
Joint Terracotta Strong Mix
Colors. Terracotta 25%
Dust 25%
Cotto 25%
Klinker 25%

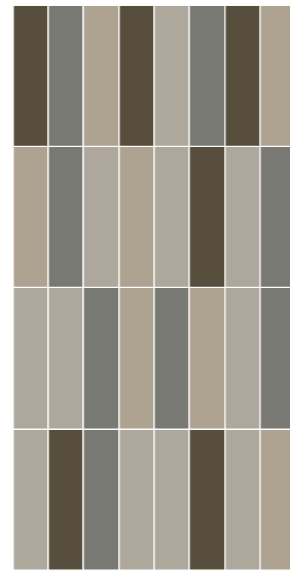

MIJNTMXS04
Joint Grey Strong Mix
Colors. Grey 25%
Mud 25%
Mou 25%
Coffee 25%

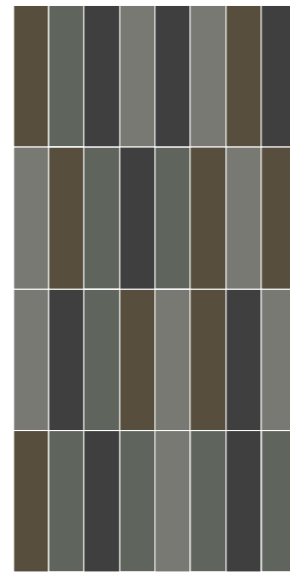

MIJNTMXS09
Joint Graphite Strong Mix
Colors. Graphite 25%
Grey 25%
Black 25%
Coffee 25%

Joint Seventies

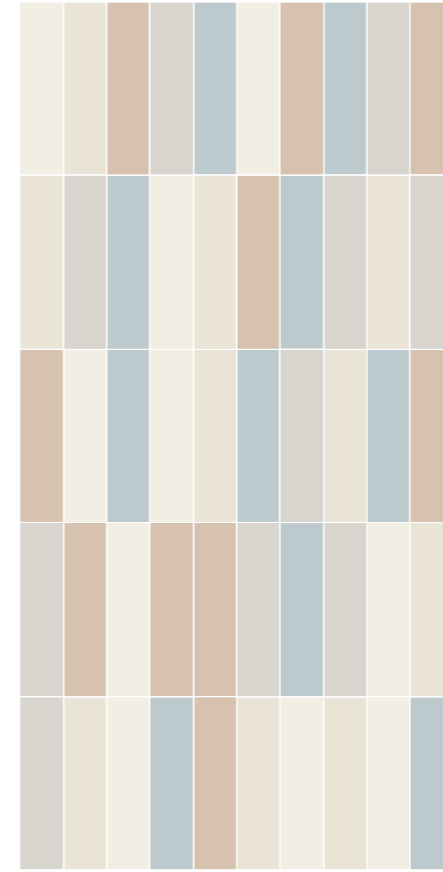

MIJNT70.01
Joint Seventies White
Colors. White 20%
Sand 20%
Dust 20%
Terracotta 20%
Azure 20%

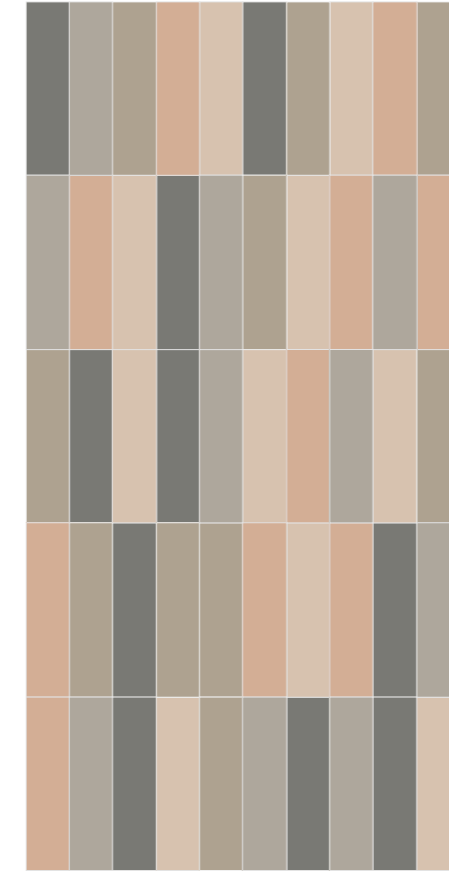

MIJNT70.04
Joint Seventies Grey
Colors. Grey 20%
Mud 20%
Mou 20%
Terracotta 20%
Cotto 20%

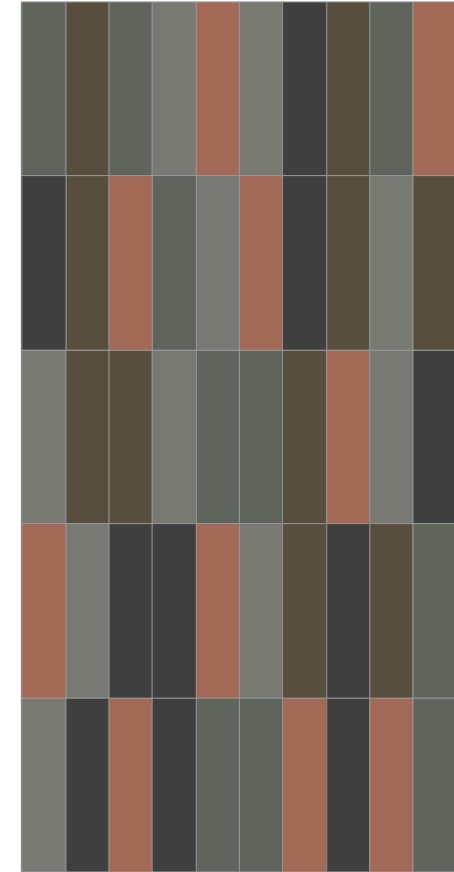

MIJNT70.09
Joint Seventies Graphite
Colors. Graphite 20%
Mud 20%
Black 20%
Coffee 20%
Klinker 20%

STUCCO
CONSIGLIATO
SUGGESTED
GROUT

102

STUCCO
CONSIGLIATO
SUGGESTED
GROUT

110

STUCCO
CONSIGLIATO
SUGGESTED
GROUT

215



Familiar

Design
Roberto Cicchinè

ITA Familiar è un progetto che nasce dal desiderio di confrontarsi con il mondo delle “graniglie”. Il grande rispetto che la filosofia Micro. ha verso le materie naturali ha portato a realizzare un prodotto che si distanzia volutamente dalla simulazione dell’originale. L’utilizzo di un filtro digitale dona alla superficie un sapore fortemente contemporaneo mantenendo vivo il ricordo del prodotto autentico. Le quattro tipologie di superfici realizzate con diverse granulometrie su 4 toni cromatici abbinabili ai 13 colori del progetto Micro. permettono un utilizzo versatile del prodotto, dal rimando elegante e più classico del monotinta sino alla giocosità della proposta mix.

ENG Familiar is a project born from the desire to deal with the world of “grits”. The great respect that Micro. philosophy has towards natural materials has led to the realization of a product that deliberately distances itself from the imitation of the original. The use of a digital filter gives the surface a highly contemporary flavour while keeping alive the memory of the authentic product. The four types of surfaces are realized with different granulometry on 4 chromatic tones which can be combined with the 13 colours of Micro., allowing a versatile use of the product, from the elegant and classic evenness of the plain colour up to the playfulness of the mix proposal.



Discover more
SCOPRI DI PIÙ

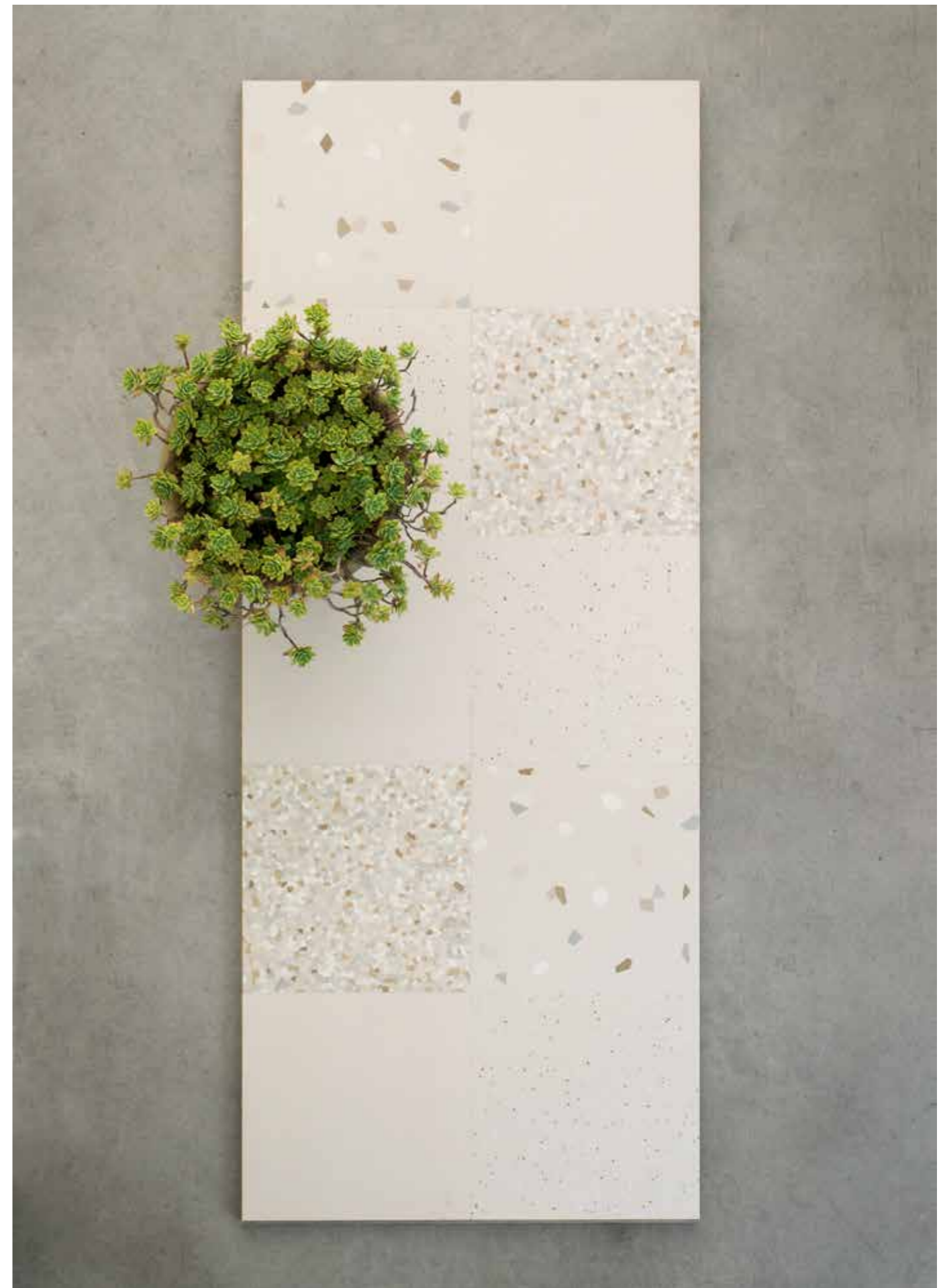

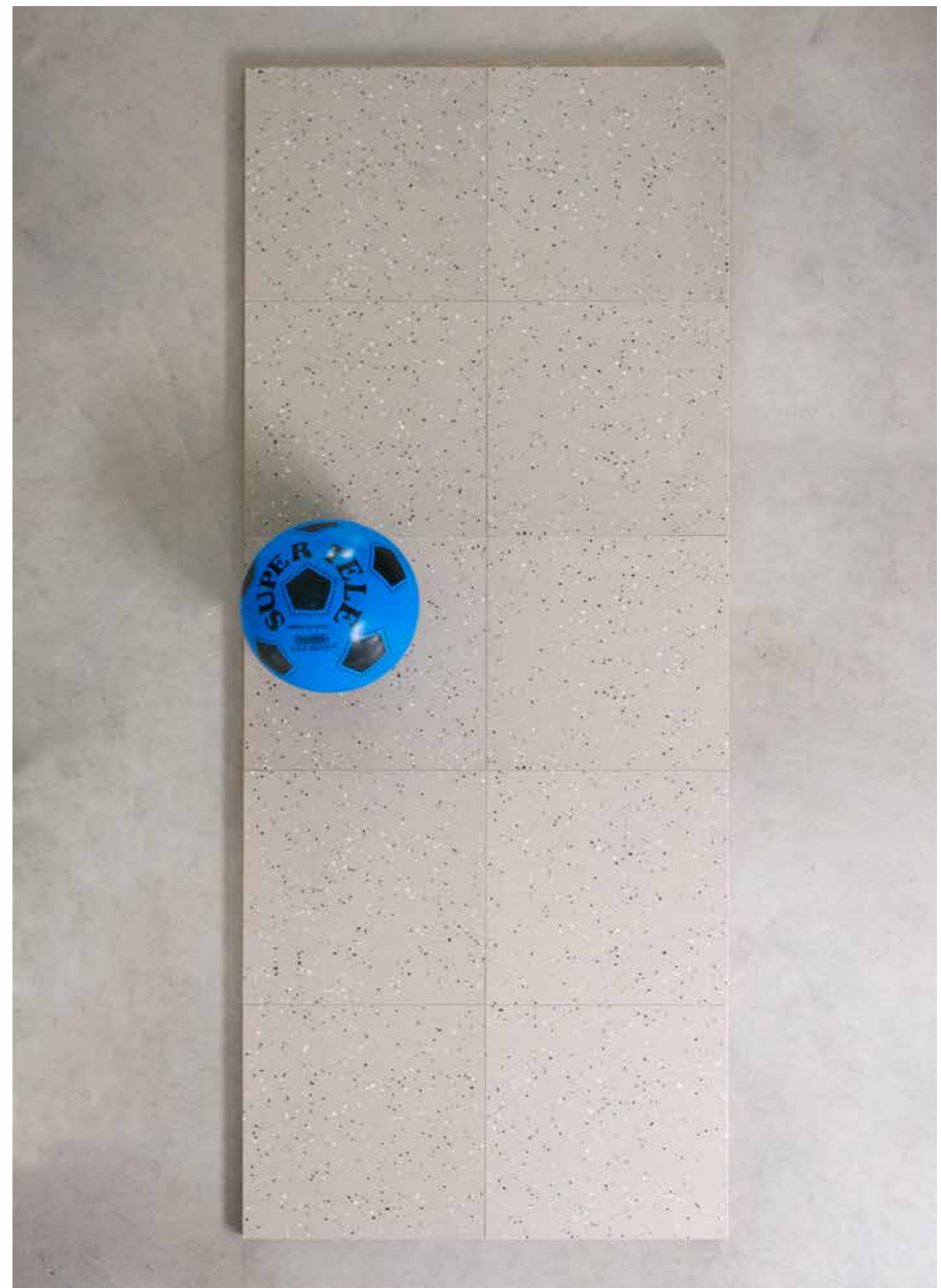

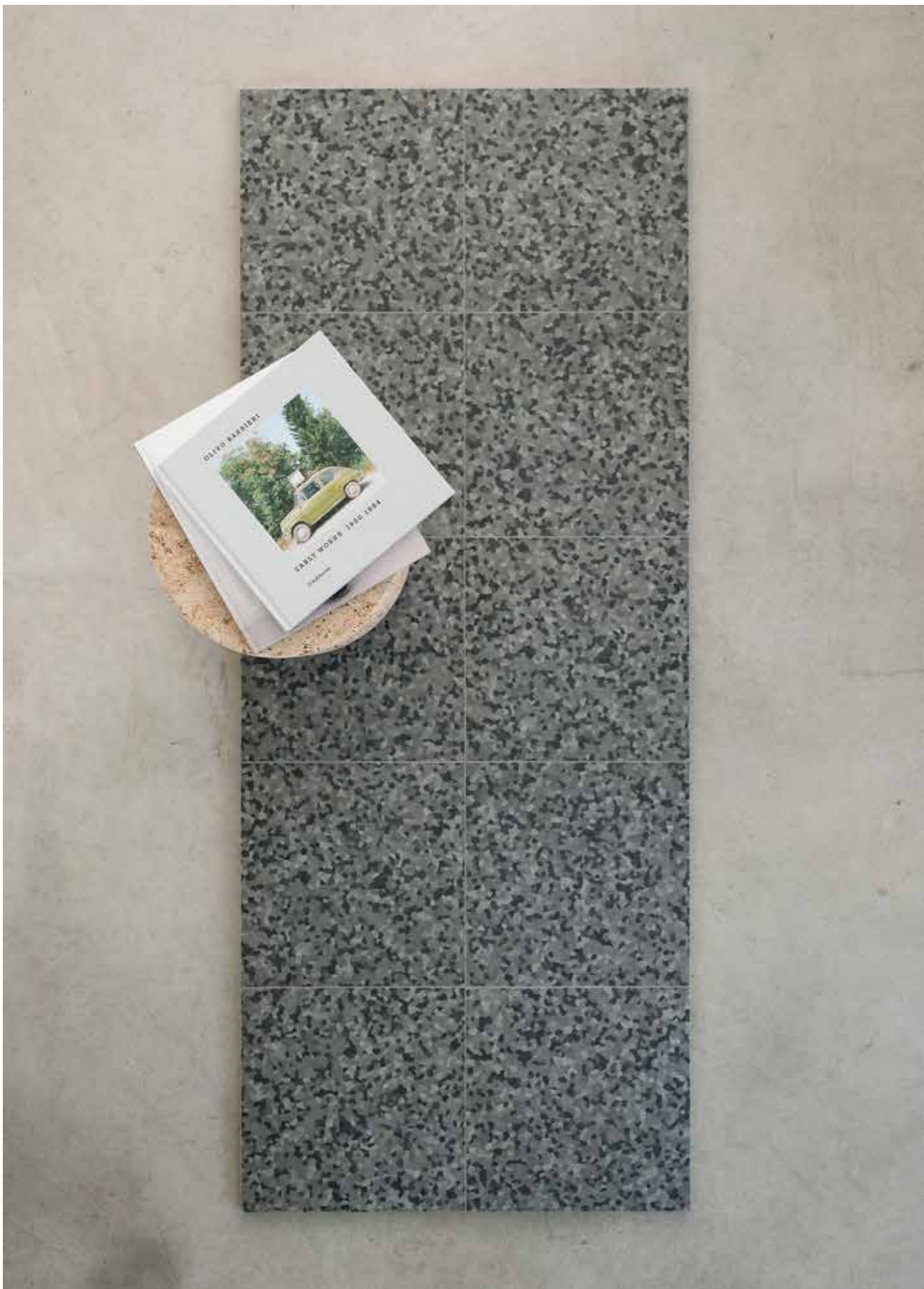

Familiar
Graphite Medium
Dust/Mud/Graphite/Coffee/Black

070



Familiar
Terracotta Large
White/Terracotta/Cotto/Klinker

071

Familiar White



MIFA01
Familiar White

MIFAS01
Familiar White Small

MIFAM01
Familiar White Medium

MIFAL01
Familiar White Large

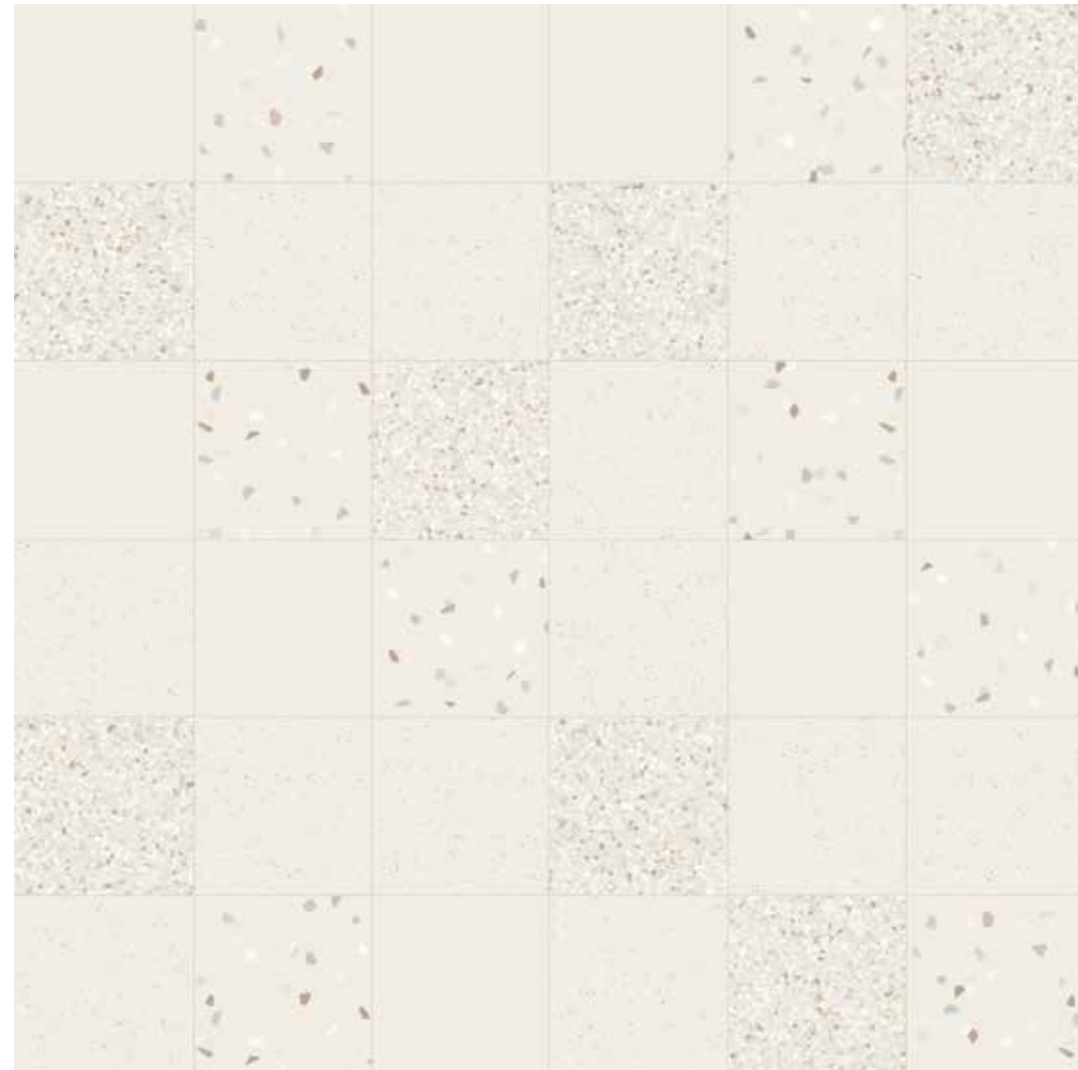

MIFAX01
Familiar White Mix
Colors. White/Sand/Dust/Azure/Mou

STUCCO
CONSIGLIATO
SUGGESTED
GROUT

110

Familiar Terracotta

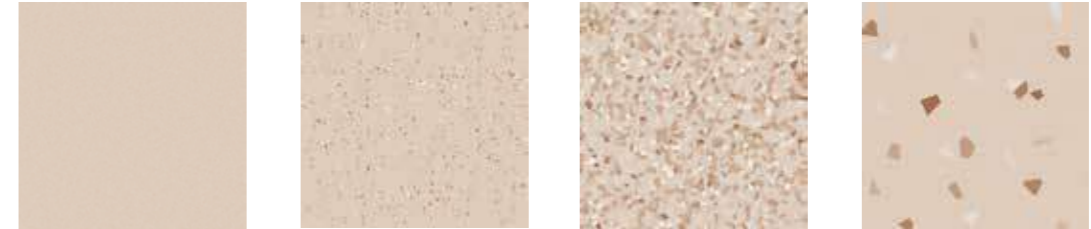

MIFA11
Familiar Terracotta

MIFAS11
Familiar Terracotta
Small

MIFAM11
Familiar Terracotta
Medium

MIFAL11
Familiar Terracotta
Large

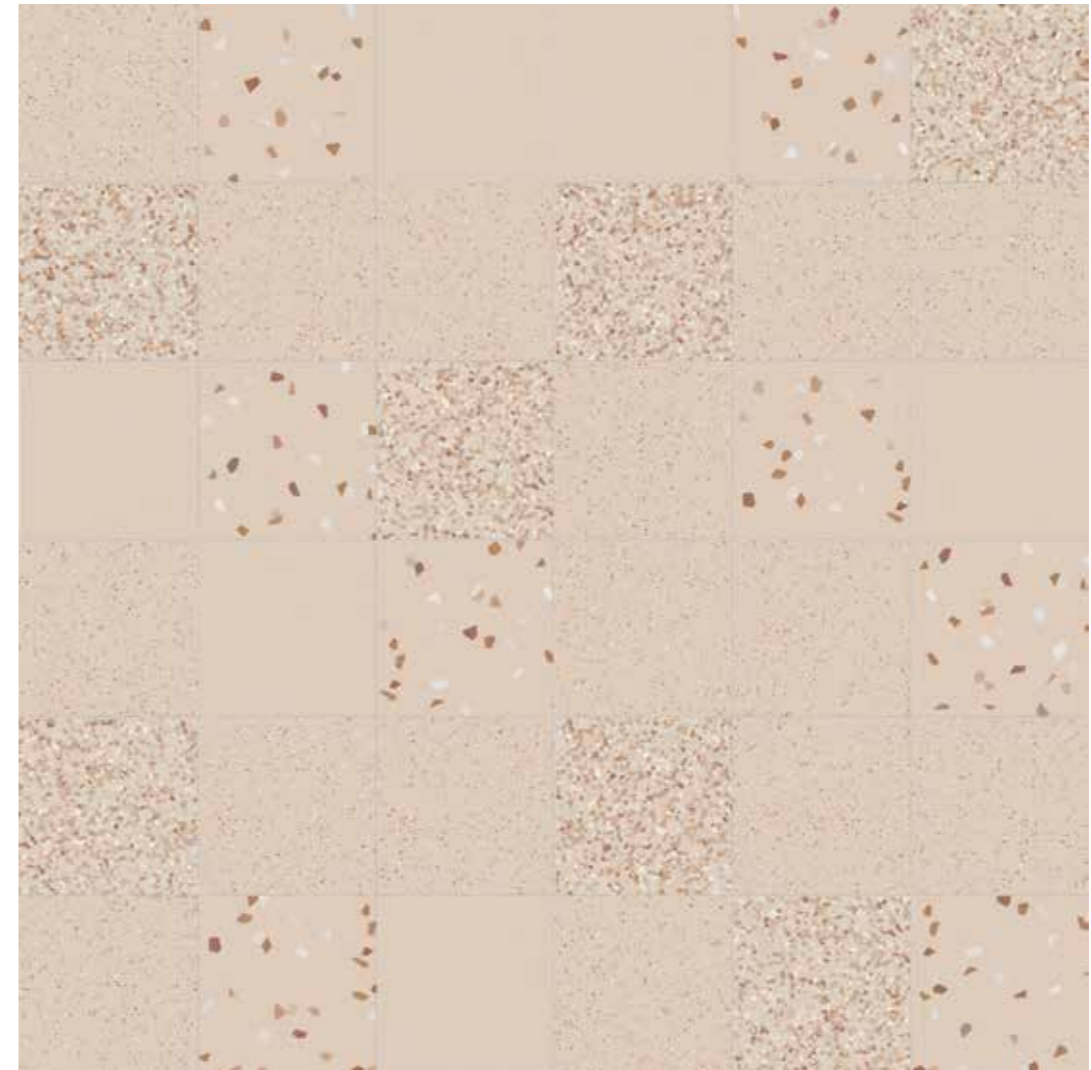

MIFAX11
Familiar Terracotta Mix
Colors. White/Terracotta/Cotto/Klinker

STUCCO
CONSIGLIATO
SUGGESTED
GROUT

110

Familiar Grey

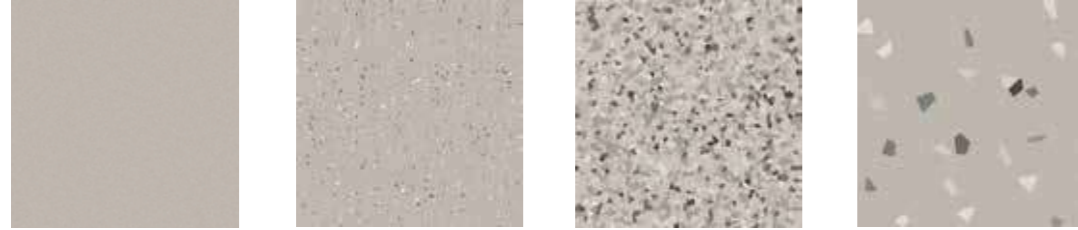

MIFA04 Familiar Grey
 MIFAS04 Familiar Grey Small
 MIFAM04 Familiar Grey Medium
 MIFAL04 Familiar Grey Large

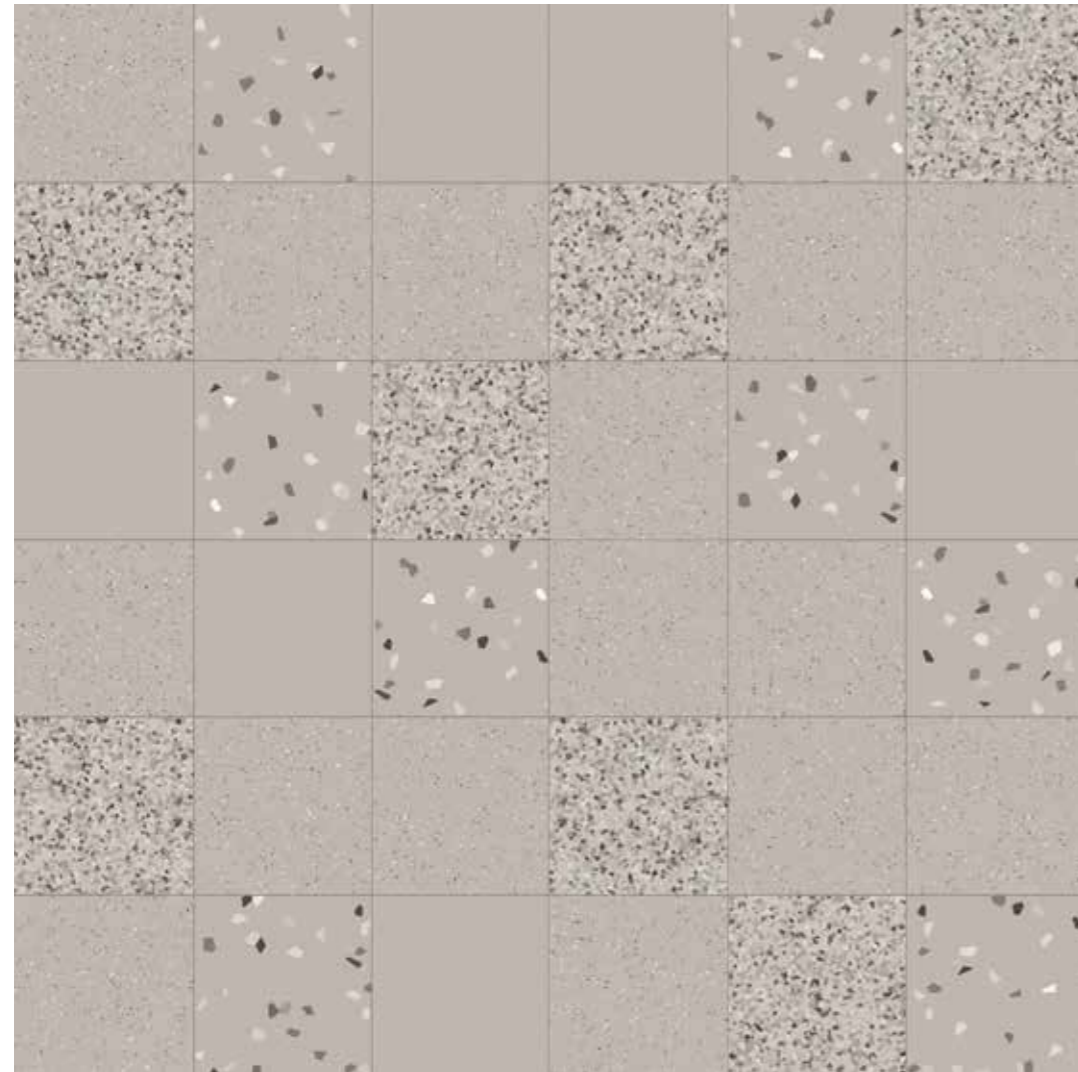

MIFAX04 Familiar Grey Mix
 Colors. Dust/Grey/Mud/Coffee/Black

STUCCO
 CONSIGLIATO
 SUGGESTED
 GROUT

215

Familiar Graphite

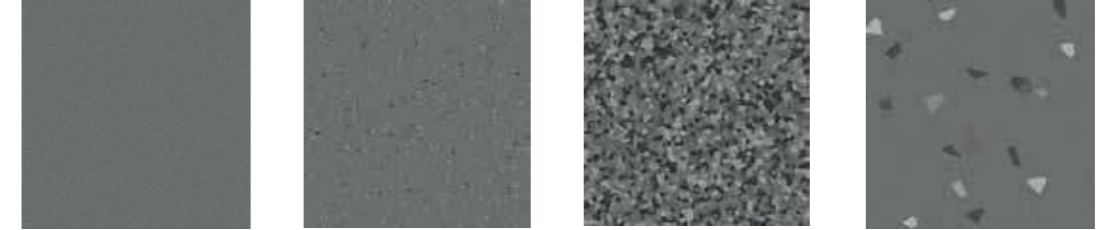

MIFA09 Familiar Graphite
 MIFAS09 Familiar Graphite Small
 MIFAM09 Familiar Graphite Medium
 MIFAL09 Familiar Graphite Large

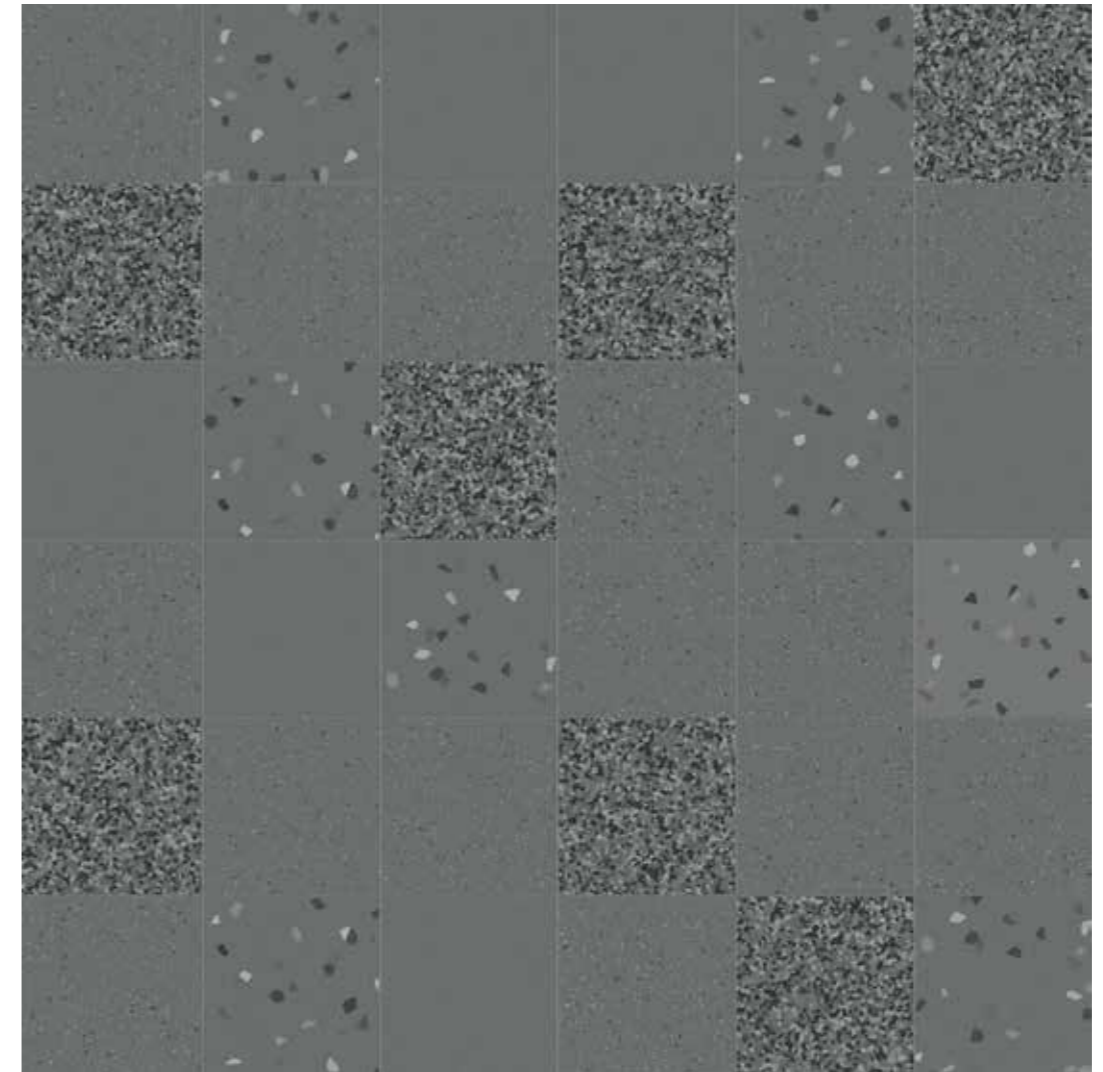

MIFAX09 Familiar Graphite Mix
 Colors. Dust/Mud/Graphite/Coffee/Black

STUCCO
 CONSIGLIATO
 SUGGESTED
 GROUT

125



Perlinato

Design
Roberto Cicchinè

ITA Perlinato è un progetto che si ispira alle superfici in legno tipiche in edilizia particolarmente utilizzate negli anni '70 come rivestimenti decorativi. Doghe ceramiche create per trafilatura e realizzate con maschiature sui lati lunghi permettono l'incastro degli elementi a creare una superficie monolitica senza l'utilizzo dello stucco tra una doga e l'altra. Prendendo in prestito dall'originale il sapore démodé, questo perlinato ceramico, con l'aiuto di elementi angolari e di chiusura, decora pareti con zoccolature o campiture piene nei vari ambienti della casa. L'utilizzo nei 13 toni cromatici rafforza la capacità del progetto di adattarsi a molteplici atmosfere da creare e condividere con le altre collezioni del progetto Micro.

ENG Perlinato is a project inspired by the typical wooden surfaces characteristic of construction, particularly used in the '70s as decorative coverings. Ceramic slats created through a die and made with tapping on the long sides allow the joints of the elements to create a monolithic surface without the use of grout between one slat and the other. Borrowing the old-fashioned flavour from the original inspiration, this ceramic Perlinato (matchboarding), with the help of angular elements and closure, decorates walls with plinths or full coverings in the various spaces of the house. The use of the 13 chromatic tones reinforces the ability of the project to adapt to multiple atmospheres to be created and shared with the other Micro.'s collections.



Discover more
SCOPRI DI PIÙ



Familiar Terracotta Medium
White/Terracotta
Cotto/Klinker

Perlinato Klinker
Small Board Klinker
Large Board Klinker

078



Micro. Familiar Grey Large
Dust/Grey/Mud/Coffee/Black

Perlinato Graphite
Small Board Graphite

Micropapers Blends
Graphite/Joint Mud

079





Perlinato
Klinker
Small Board Klinker

Micropapers
Oddfellow Mix
Grey/Mud/Klinker



Perlinato White
Perlinato Small Board White
Perlinato Large Board White



Perlinato Graphite
Small Board Graphite
Large Board Graphite

Micropapers
Grid x4 Black/Joint
Graphite

084



Perlinato
Azure

085

Perlinato

7,5x100 cm / 3x40 inches

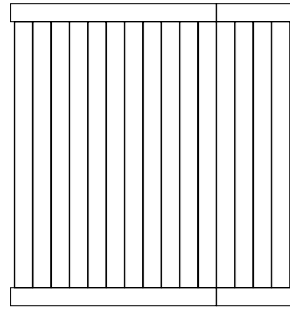

STUCCO
CONSIGLIATO
SUGGESTED
GROUT

MIPE01	Perlinato White	102	
MIPE02	Perlinato Sand	205	
MIPE03	Perlinato Dust	110	
MIPE04	Perlinato Grey	215	
MIPE05	Perlinato Mud	120	
MIPE06	Perlinato Mou	225	
MIPE07	Perlinato Black	140	
MIPE08	Perlinato Coffee	232	
MIPE09	Perlinato Graphite	130	
MIPE10	Perlinato Azure	105	
MIPE11	Perlinato Terracotta	110	
MIPE12	Perlinato Cotto	110	
MIPE13	Perlinato Klinker	110	

Perlinato Small Board

7x100 cm / 3x40 inches

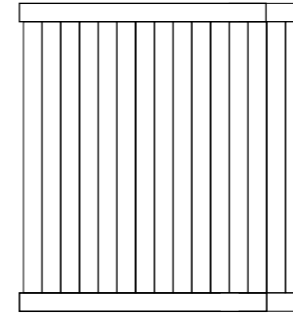

MIPES01	Perlinato Small Board White
MIPES02	Perlinato Small Board Sand
MIPES03	Perlinato Small Board Dust
MIPES04	Perlinato Small Board Grey
MIPES05	Perlinato Small Board Mud
MIPES06	Perlinato Small Board Mou
MIPES07	Perlinato Small Board Black
MIPES08	Perlinato Small Board Coffee
MIPES09	Perlinato Small Board Graphite
MIPES10	Perlinato Small Board Azure
MIPES11	Perlinato Small Board Terracotta
MIPES12	Perlinato Small Board Cotto
MIPES13	Perlinato Small Board Klinker

Perlinato Large Board

17x100 cm / 7x40 inches

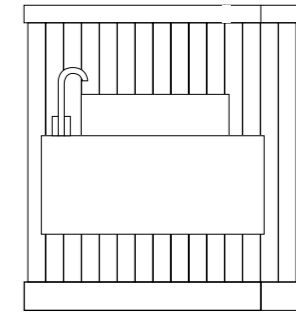

MIPEL01	Perlinato Large Board White
MIPEL02	Perlinato Large Board Sand
MIPEL03	Perlinato Large Board Dust
MIPEL04	Perlinato Large Board Grey
MIPEL05	Perlinato Large Board Mud
MIPEL06	Perlinato Large Board Mou
MIPEL07	Perlinato Large Board Black
MIPEL08	Perlinato Large Board Coffee
MIPEL09	Perlinato Large Board Graphite
MIPEL10	Perlinato Large Board Azure
MIPEL11	Perlinato Large Board Terracotta
MIPEL12	Perlinato Large Board Cotto
MIPEL13	Perlinato Large Board Klinker

Perlinato Small Corner

7 cm / 3 inches

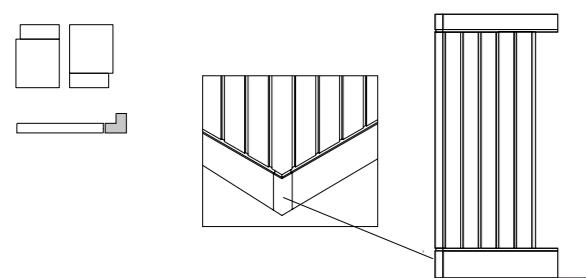

- MIPESC01 Perlinato Small Corner White
- MIPESC02 Perlinato Small Corner Sand
- MIPESC03 Perlinato Small Corner Dust
- MIPESC04 Perlinato Small Corner Grey
- MIPESC05 Perlinato Small Corner Mud
- MIPESC06 Perlinato Small Corner Mou
- MIPESC07 Perlinato Small Corner Black
- MIPESC08 Perlinato Small Corner Coffee
- MIPESC09 Perlinato Small Corner Graphite
- MIPESC10 Perlinato Small Corner Azure
- MIPESC11 Perlinato Small Corner Terracotta
- MIPESC12 Perlinato Small Corner Cotto
- MIPESC13 Perlinato Small Corner Klinker

Perlinato Large Corner

17 cm / 7 inches

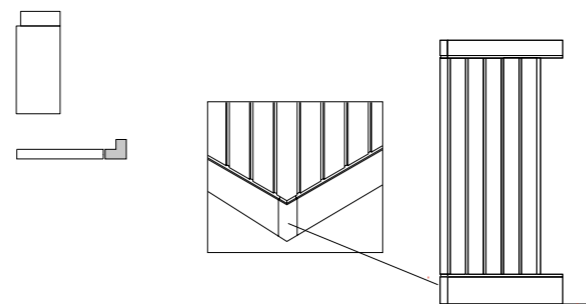

- MIPELC01 Perlinato Large Corner White
- MIPELC02 Perlinato Large Corner Sand
- MIPELC03 Perlinato Large Corner Dust
- MIPELC04 Perlinato Large Corner Grey
- MIPELC05 Perlinato Large Corner Mud
- MIPELC06 Perlinato Large Corner Mou
- MIPELC07 Perlinato Large Corner Black
- MIPELC08 Perlinato Large Corner Coffee
- MIPELC09 Perlinato Large Corner Graphite
- MIPELC10 Perlinato Large Corner Azure
- MIPELC11 Perlinato Large Corner Terracotta
- MIPELC12 Perlinato Large Corner Cotto
- MIPELC13 Perlinato Large Corner Klinker

Perlinato Corner

100 cm / 40 inches

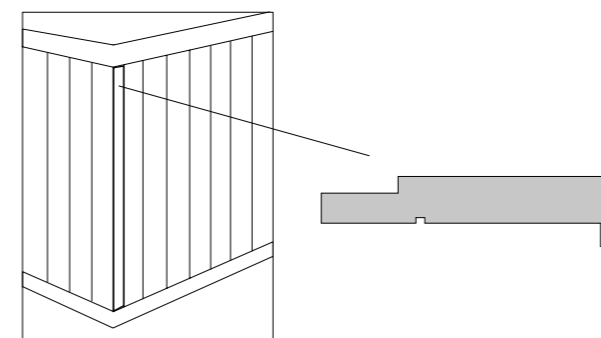

- MIPEC01 Perlinato Corner White
- MIPEC02 Perlinato Corner Sand
- MIPEC03 Perlinato Corner Dust
- MIPEC04 Perlinato Corner Grey
- MIPEC05 Perlinato Corner Mud
- MIPEC06 Perlinato Corner Mou
- MIPEC07 Perlinato Corner Black
- MIPEC08 Perlinato Corner Coffee
- MIPEC09 Perlinato Corner Graphite
- MIPEC10 Perlinato Corner Azure
- MIPEC11 Perlinato Corner Terracotta
- MIPEC12 Perlinato Corner Cotto
- MIPEC13 Perlinato Corner Klinker

Perlinato Border

3,5x100 / 1,5x7 inches

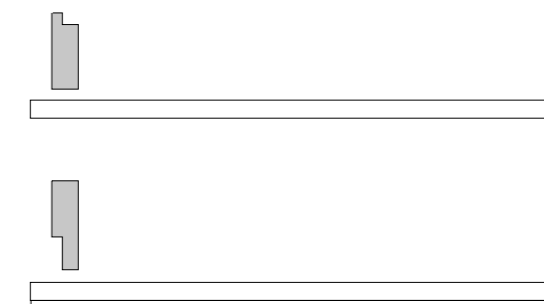

- MIPECSR01.AB Perlinato Border White
- MIPECSR02.AB Perlinato Border Sand
- MIPECSR03.AB Perlinato Border Dust
- MIPECSR04.AB Perlinato Border Grey
- MIPECSR05.AB Perlinato Border Mud
- MIPECSR06.AB Perlinato Border Mou
- MIPECSR07.AB Perlinato Border Black
- MIPECSR08.AB Perlinato Border Coffee
- MIPECSR09.AB Perlinato Border Graphite
- MIPECSR10.AB Perlinato Border Azure
- MIPECSR11.AB Perlinato Border Terracotta
- MIPECSR12.AB Perlinato Border Cotto
- MIPECSR13.AB Perlinato Border Klinker

Microtiles

Design
Roberto Cicchinè

ITA Mattonelle di piccole dimensioni disegnano, con trame e colori, infinite suggestioni. Pareti e pavimenti accolgono forme semplici sospese tra memoria e presente.

ENG Small tiles draw infinite suggestions with textures and colours. Walls and floors welcome simple shapes suspended between memory and present.



Microtiles Dimensions



Microtiles Dimensions

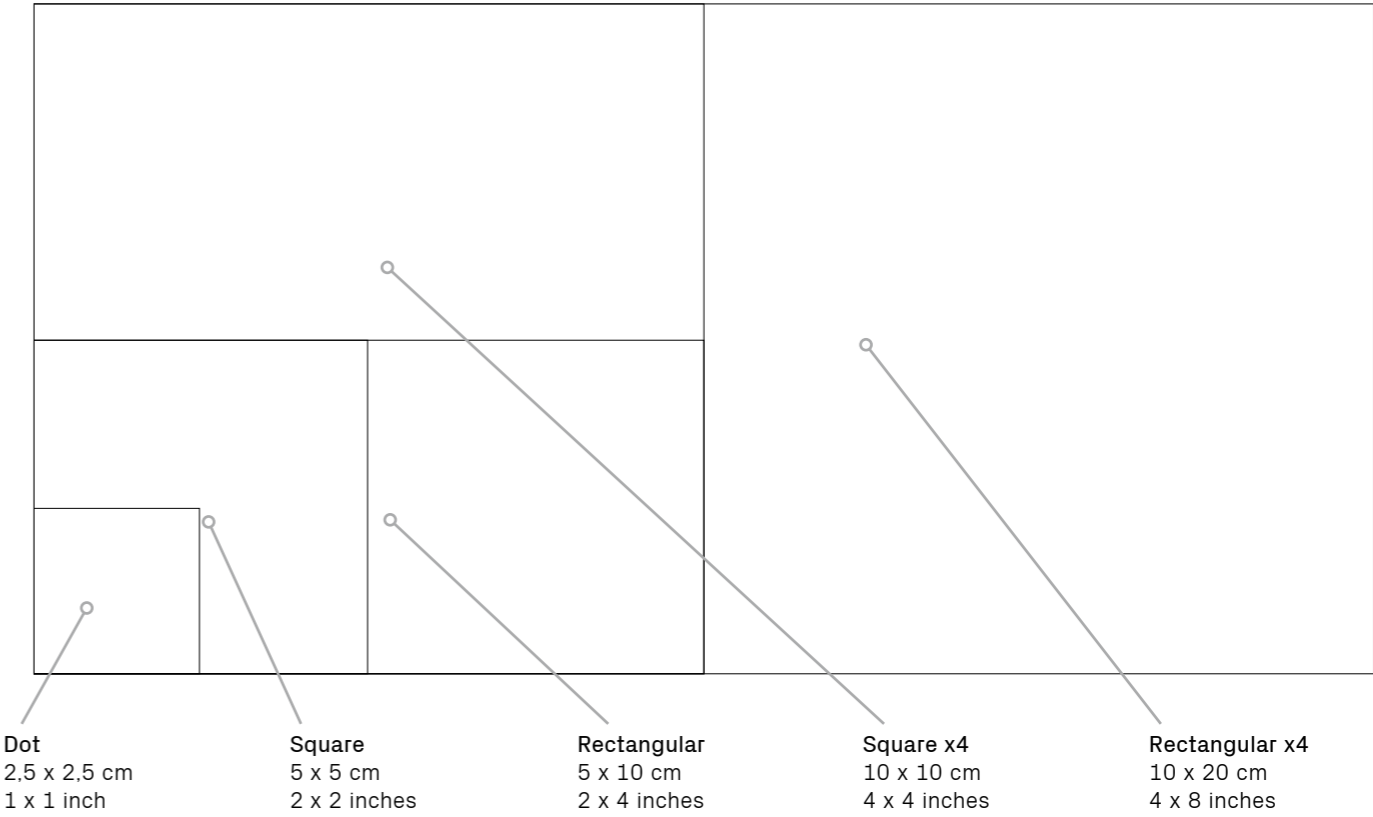

Microtiles Color Palette



White Sand Dust Grey Mud

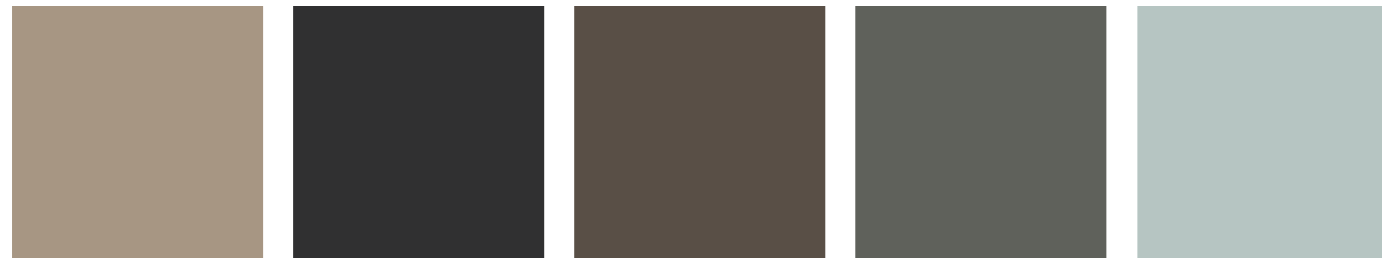

Mou Black Coffee Graphite Azure



Terracotta Cotto Klinker

Schemes

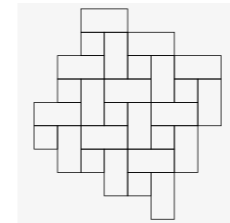

Spiral
Matt
x4 Matt
Glaze
x4 Glaze
Mix Glaze
x4 Mix Glaze

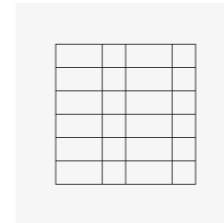

Knit
Matt
x4 Matt
Glaze
x4 Glaze
Mix Glaze
x4 Mix Glaze

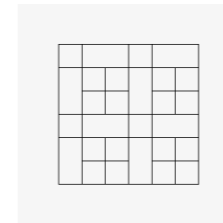

Plaid
Matt
x4 Matt
Glaze
x4 Glaze
Mix Glaze
x4 Mix Glaze

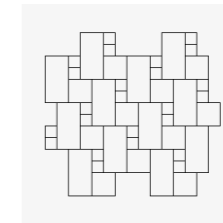

Offset
Matt
x4 Matt
Glaze
x4 Glaze
Mix Glaze
x4 Mix Glaze

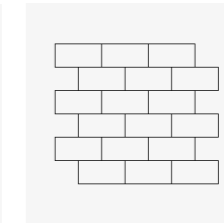

Subway
Matt
Glaze
Mix Glaze

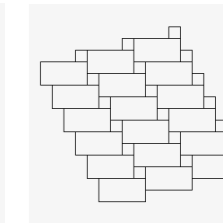

Old
Matt
x4 Matt
Glaze
x4 Glaze
Mix Glaze
x4 Mix Glaze

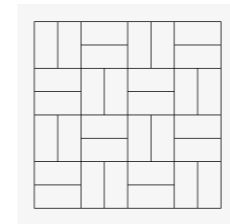

Basket
Matt
x4 Matt
Glaze
x4 Glaze
Mix Glaze
x4 Mix Glaze

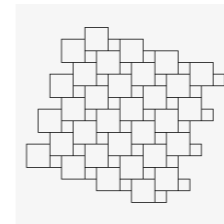

Oddfellow
Matt
x4 Matt
Glaze
x4 Glaze
Mix Glaze
x4 Mix Glaze

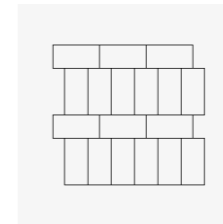

Rough
Matt
Glaze
Mix Glaze

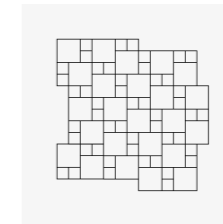

Double
Matt
x4 Matt
Glaze
x4 Glaze
Mix Glaze
x4 Mix Glaze

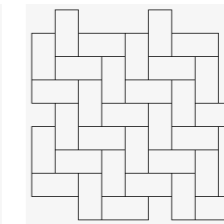

Herringbone
Matt
Glaze
Mix Glaze

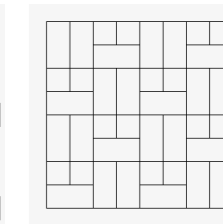

Modern
Matt
x4 Matt
Glaze
x4 Glaze
Mix Glaze
x4 Mix Glaze

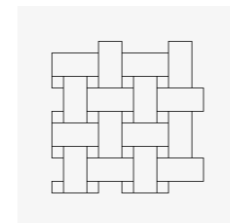

Ancient
Matt
x4 Matt
Glaze
x4 Glaze
Mix Glaze
x4 Mix Glaze

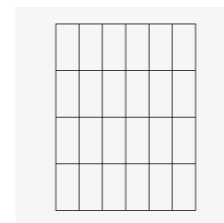

Grid
Matt
x4 Matt
Glaze
x4 Glaze
Mix Glaze
x4 Mix Glaze
Campiture
Campiture x4

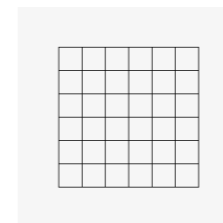

Blends
Matt
x4 Matt
Glaze
x4 Glaze
Mix Glaze
x4 Mix Glaze
Campiture
Campiture x4

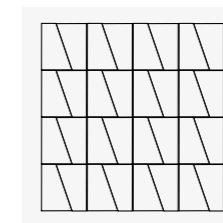

Trapezi
Matt
Glaze
Mix Glaze
Mix



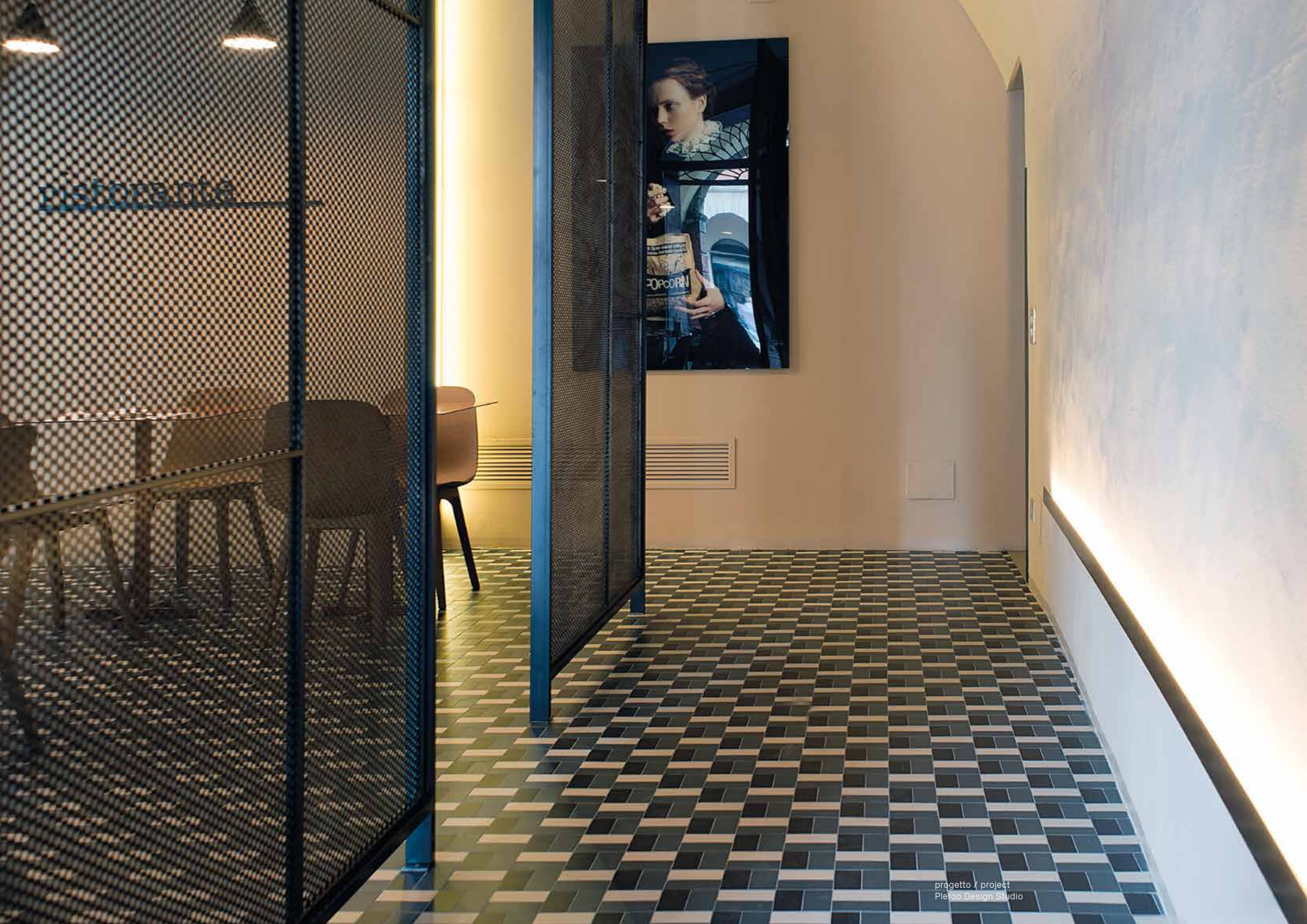

ristorante





SBIZZURÀ















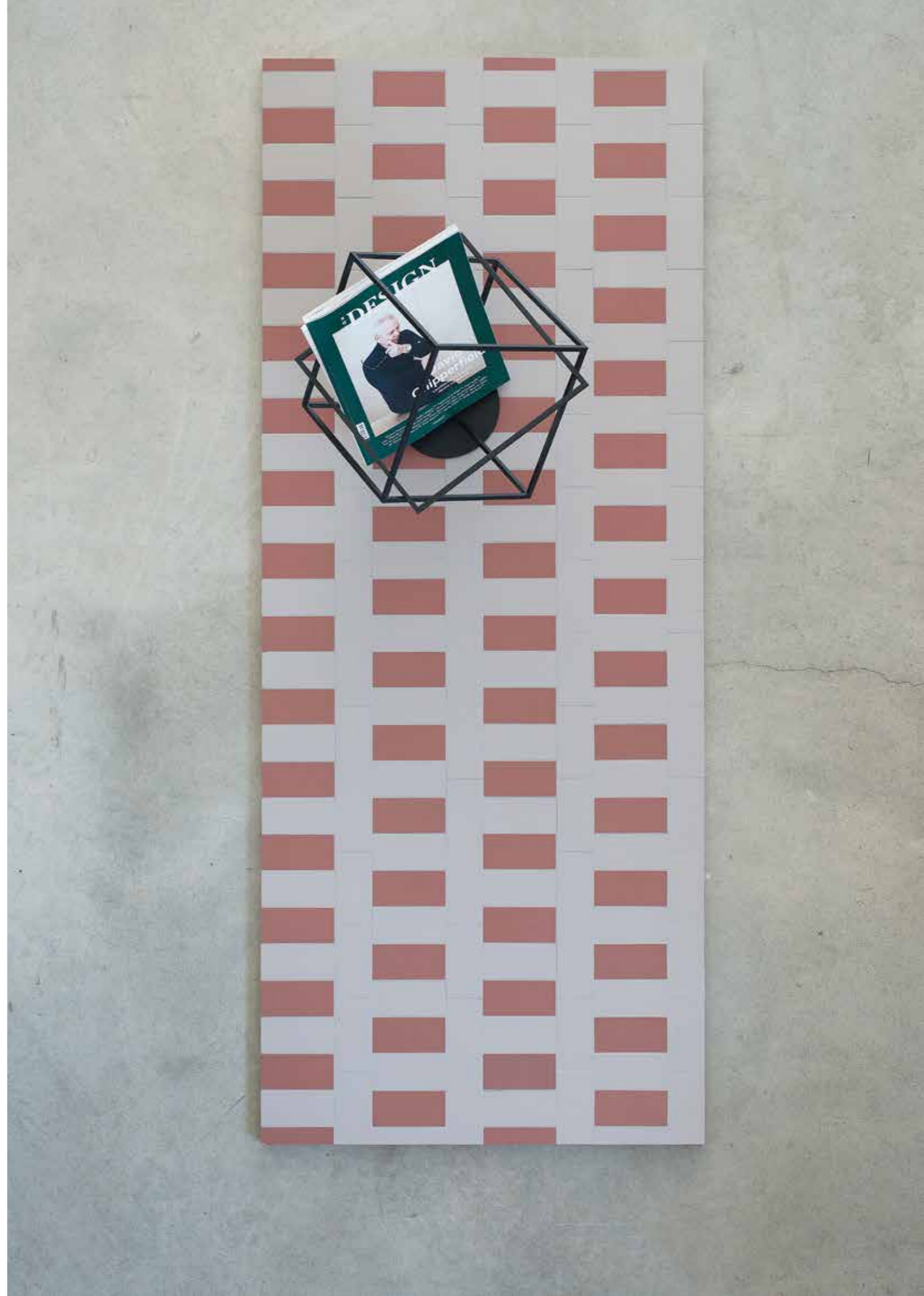

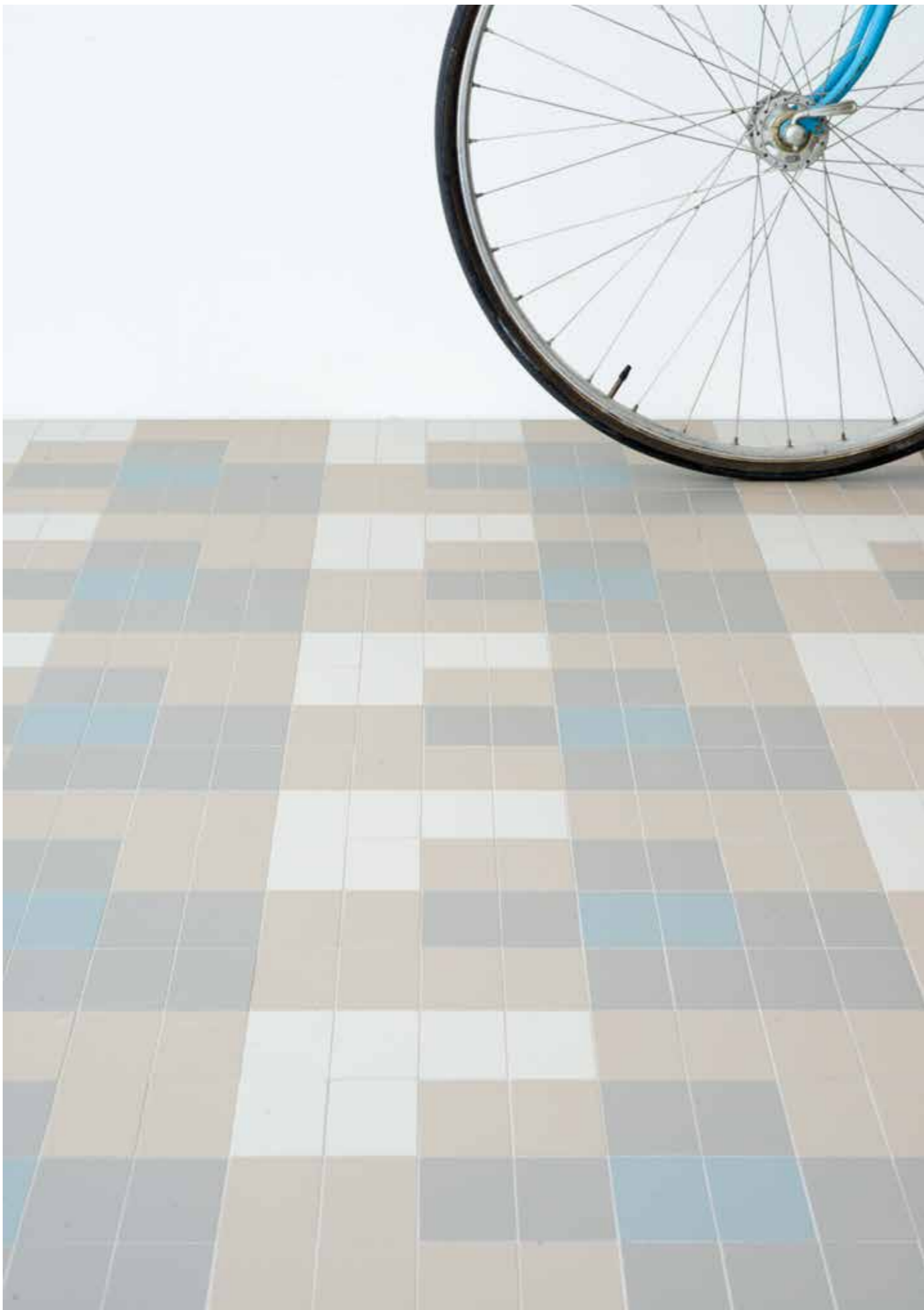









Scheme: Herringbone Mix
Mud/Graphite

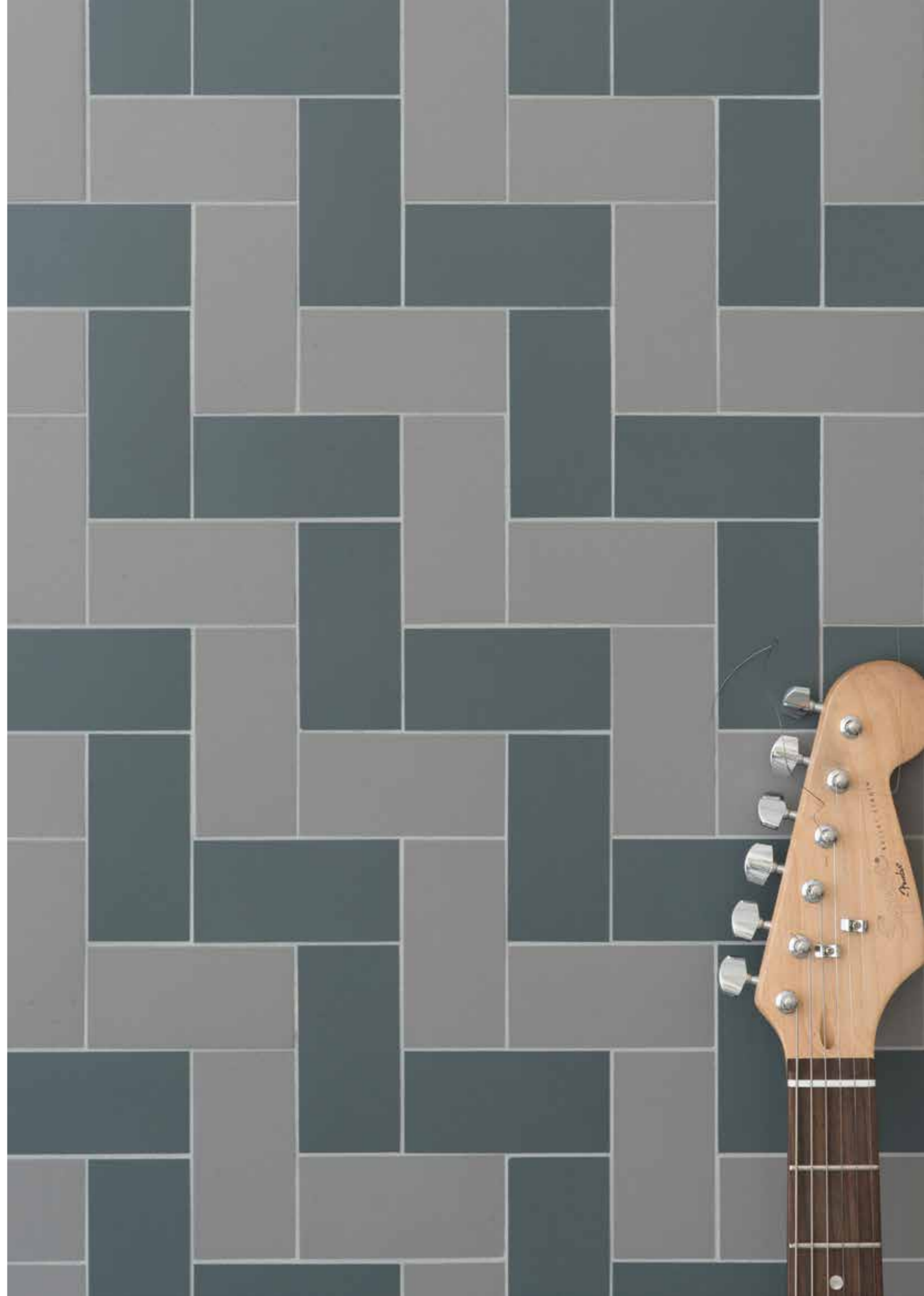







Micropapers

Design
Roberto Cicchinè

ITA Trame geometriche di piccole dimensioni
disegnano sulla carta suggestioni colorate.

ENG Small geometric textures draw colourful
suggestions on paper.

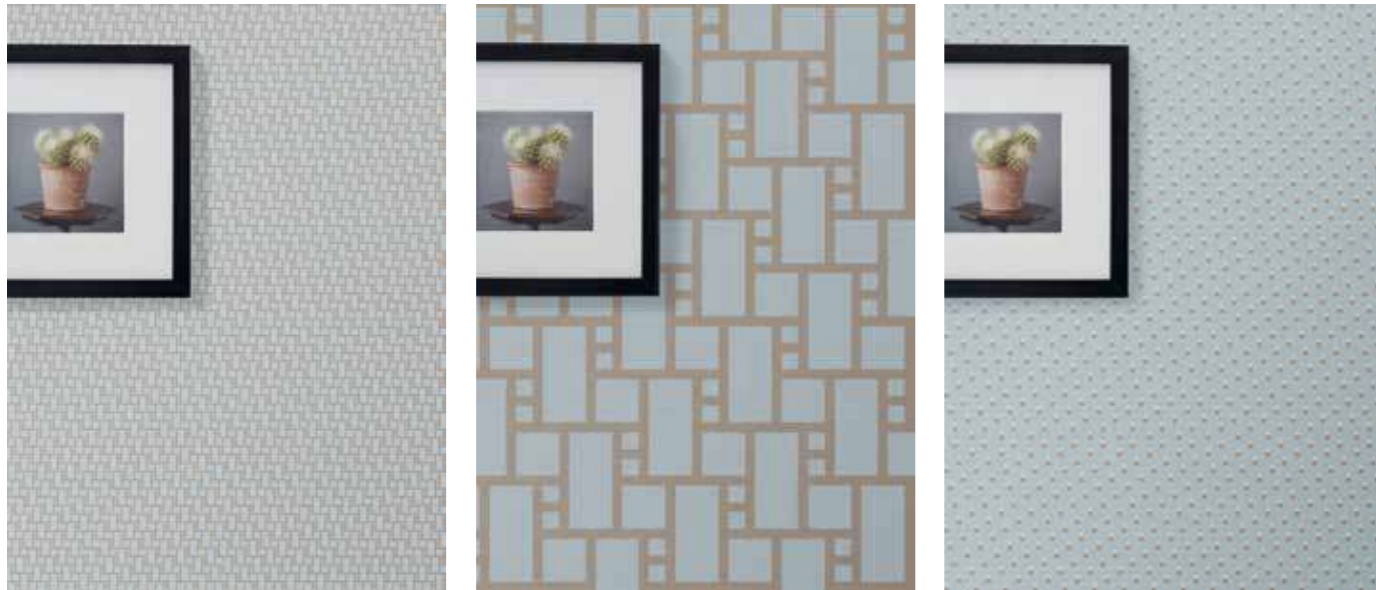



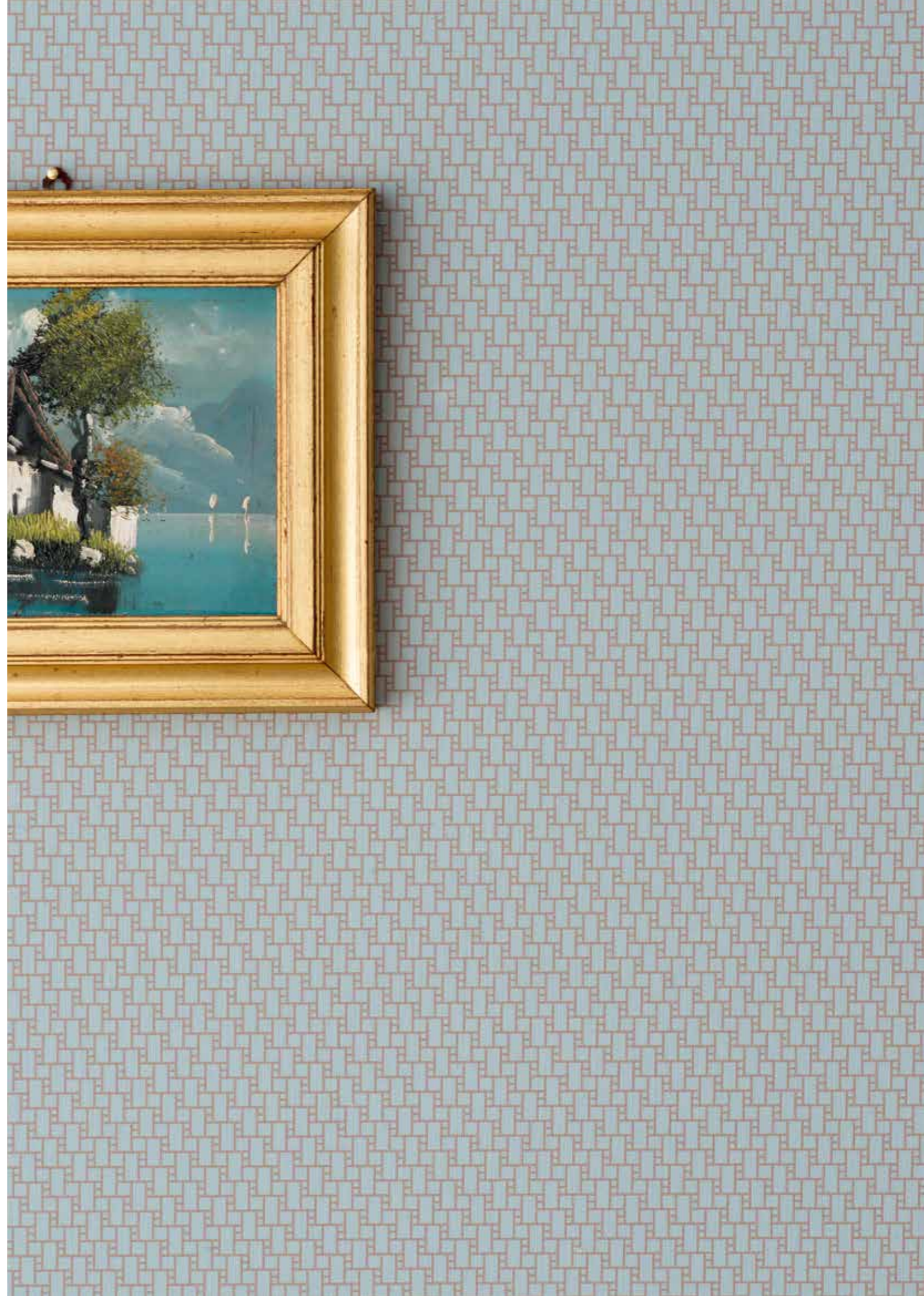





Micropapers

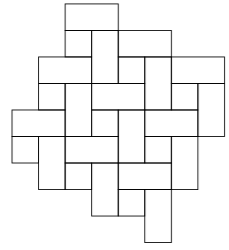

Spiral
48 x 300 cm
19 x 118 inches

100 x 300 cm
40 x 118 inches



MP01J02.901
Spiral
White/Joint Sand

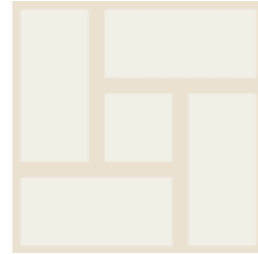

MPX01J02.901
Spiral x4
White/Joint Sand



MPS02R01.901
Spiral Mix
White/Sand

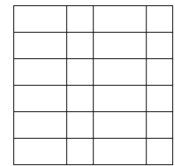

Knit
48 x 300 cm
19 x 118 inches

100 x 300 cm
40 x 118 inches

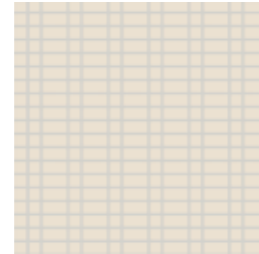

MP02J03.902
Knit
Sand/Joint Dust

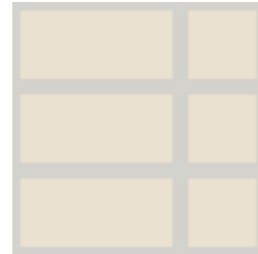

MPX02J03.902
Knit x4
Sand/Joint Dust

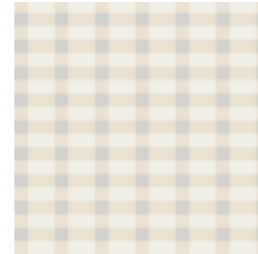

MPS02S03R01R02.902
Knit Mix
White/Sand/Dust

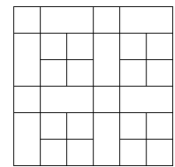

Plaid
48 x 300 cm
19 x 118 inches

100 x 300 cm
40 x 118 inches

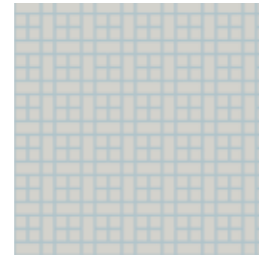

MP03J10.903
Plaid
Dust/Joint Azure



MPX03J10.903
Plaid x4
Dust/Joint Azure

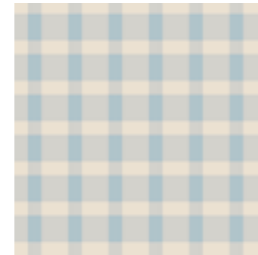

MPS03S10R02R10.903
Plaid Mix
Sand/Dust/Azure

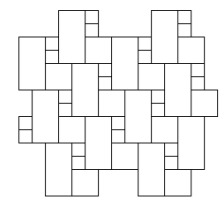

Offset
48 x 300 cm
19 x 118 inches

100 x 300 cm
40 x 118 inches



MP10J06.904
Offset
Azure/Joint Mou



MPX10J06.904
Offset x4
Azure/Joint Mou



MPD03D06S10R10.904
Offset Mix
Dust/Mou/Azure

Micropapers

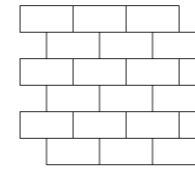

Subway
48 x 300 cm
19 x 118 inches

100 x 300 cm
40 x 118 inches

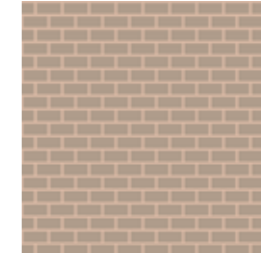

MP06J10.905
Subway
Mou/Joint Terracotta



MPX06J10.905
Subway x4
Mou/Joint Terracotta

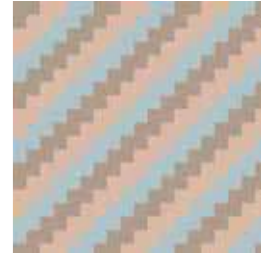

MPR06R10R11.905
Subway Mix
Mou/Azure/Terracotta

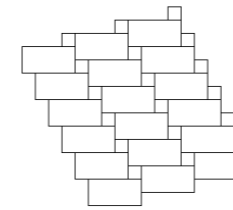

Old
48 x 300 cm
19 x 118 inches

100 x 300 cm
40 x 118 inches

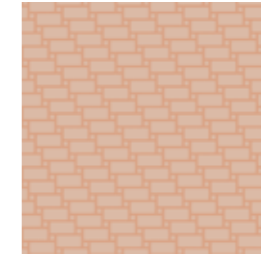

MP10J11.906
Old
Terracotta/Joint Cotto



MPX10J11.906
Old x4
Terracotta/Joint Cotto

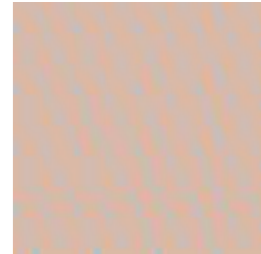

MPD10R11.906
Old Mix
Azure/Terracotta

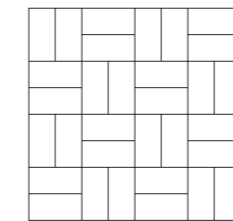

Basket
48 x 300 cm
19 x 118 inches

100 x 300 cm
40 x 118 inches

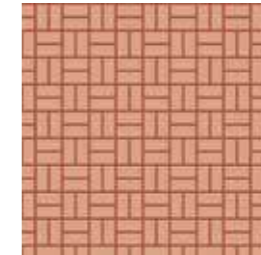

MP11J13.907
Basket
Cotto/Joint Klinker

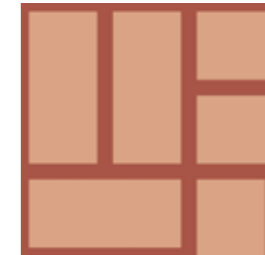

MPX11J12.907
Basket x4
Cotto/Joint Terracotta



MPR06R12R13.907
Basket Mix
Mou/Cotto/Klinker

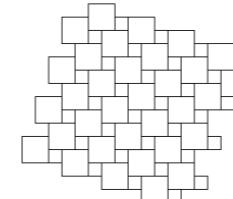

Oddfellow
48 x 300 cm
19 x 118 inches

100 x 300 cm
40 x 118 inches



MP13J04.908
Oddfellow
Klinker/Joint Grey



MPX13J04.908
Oddfellow x4
Klinker/Joint Grey

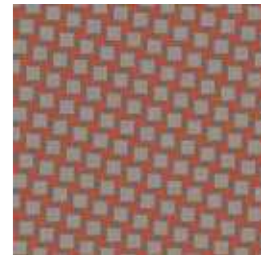

MPD05S04S13.908
Oddfellow Mix
Grey/Mud/Klinker

Micropapers

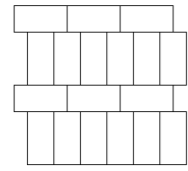

Rough
48 x 300 cm
19 x 118 inches

100 x 300 cm
40 x 118 inches

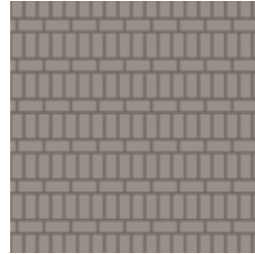

MP04J05.909
Rough
Grey/Joint Mud



MPX04J05.909
Rough x4
Grey/Joint Mud

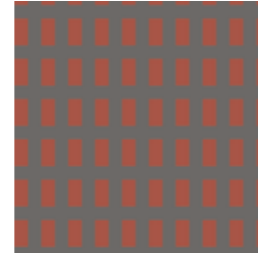

MPD05S04S13.908
Rough Mix
Mud/Klinker

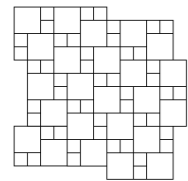

Double
48 x 300 cm
19 x 118 inches

100 x 300 cm
40 x 118 inches

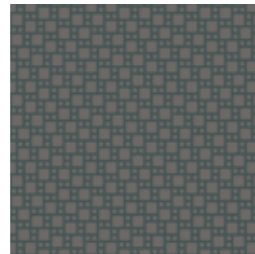

MP05J09.910
Double
Mud/Joint Graphite



MPX05J09.910
Double x4
Mud/Joint Graphite



MPD04D05S09.910
Double Mix
Grey/Mud/Graphite

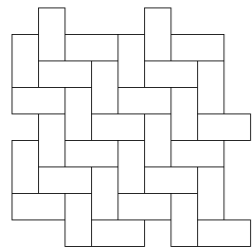

Herringbone
48 x 300 cm
19 x 118 inches

100 x 300 cm
40 x 118 inches

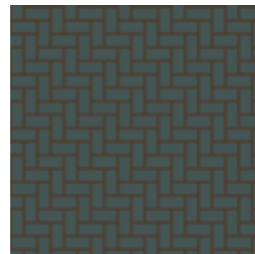

MP09J08.911
Herringbone
Graphite/Joint Coffee



MPX09J08.911
Herringbone x4
Graphite/Joint Coffee



MPR08R09.911
Herringbone Mix
Coffee/Graphite

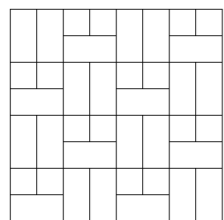

Modern
48 x 300 cm
19 x 118 inches

100 x 300 cm
40 x 118 inches



MP08J07.912
Modern
Coffee/Joint Black



MPX08J07.912
Modern x4
Coffee/Joint Black

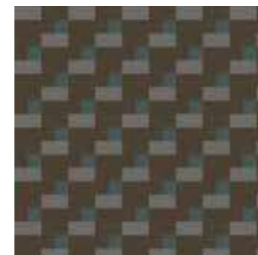

MPS08S09R05R08.912
Modern Mix
Grey/Coffee/Graphite

Micropapers

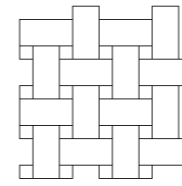

Ancient
48 x 300 cm
19 x 118 inches

100 x 300 cm
40 x 118 inches

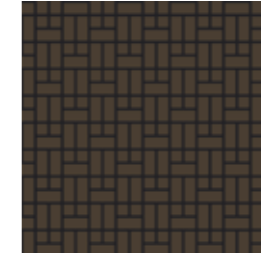

MP07J08.913
Ancient
Black/Joint Coffee



MPX07J08.913
Ancient x4
Black/Joint Coffee

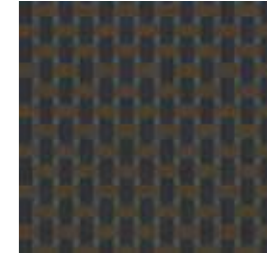

MPD09R07R08.913
Ancient Mix
Black/Coffee/Graphite

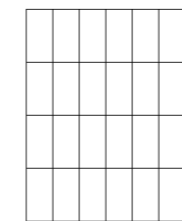

Grid
48 x 300 cm
19 x 118 inches

100 x 300 cm
40 x 118 inches

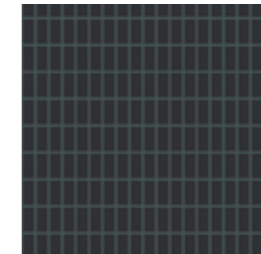

MP07J09.915
Grid
Black/Joint Graphite



MPX07J09.915
Grid x4
Black/Joint Graphite

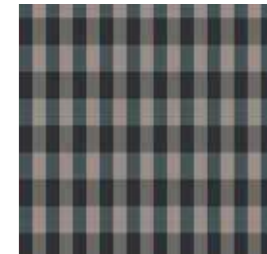

MPR04R05R07R09.915
Grid Mix
Grey/Mud/Black/Graphite

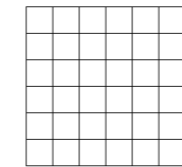

Blends
48 x 300 cm
19 x 118 inches

100 x 300 cm
40 x 118 inches

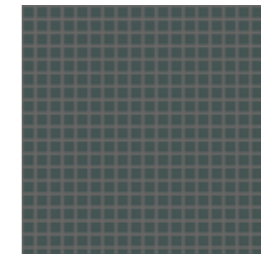

MP09J05.05
Blends
Graphite/Joint Mud



MPX09J05.14
Blends x4
Graphite/Joint Mud



MPS07S08S09.20
Blends Mix
Black/Coffee/Graphite

Micromosaics

Design
Claudio Silvestrin

ITA Pensieri e creatività differenti producono superfici senza tempo con piccole tessere colorate.

ENG Different thoughts and creativity produce coloured surfaces with small, timeless surfaces.





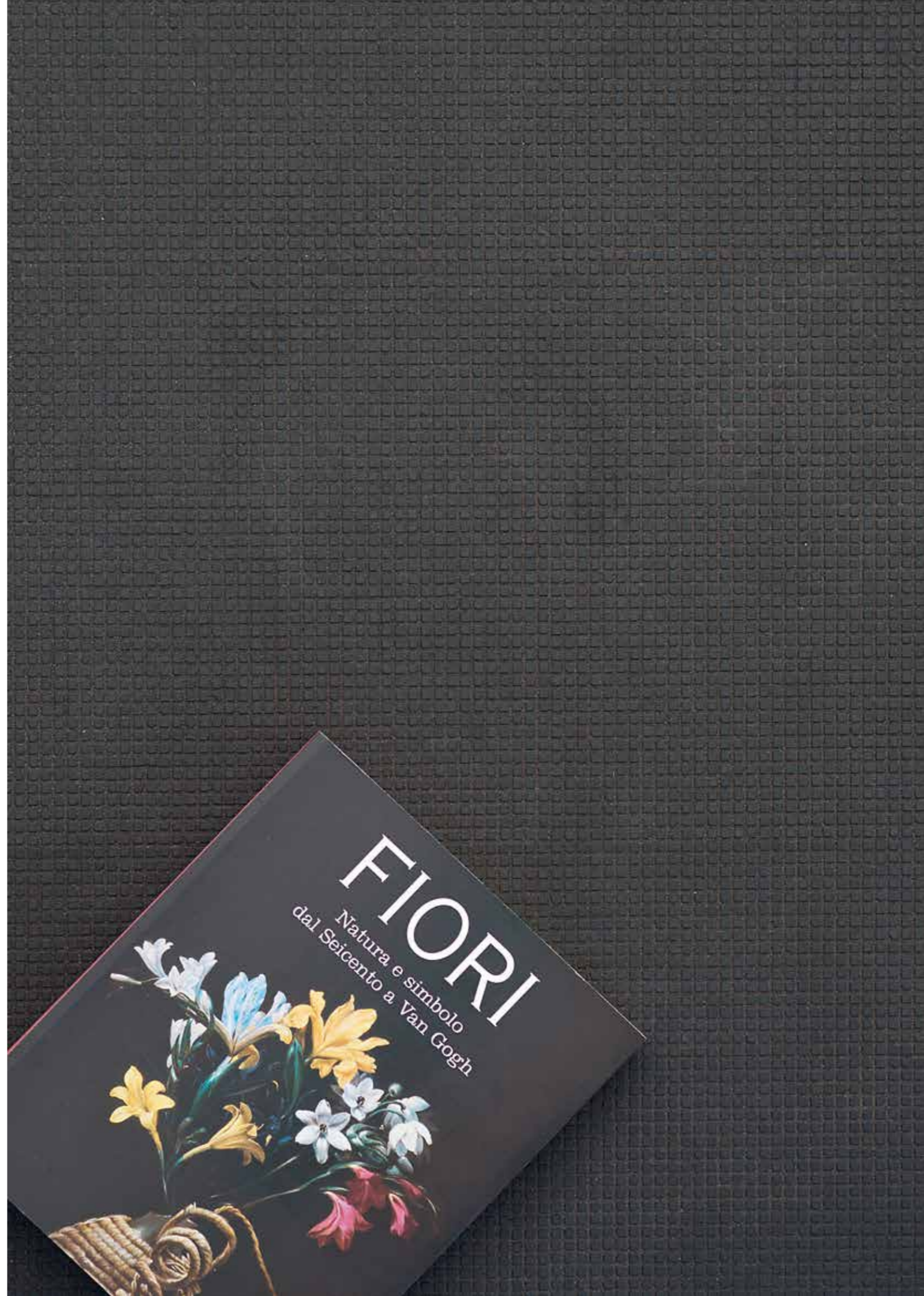

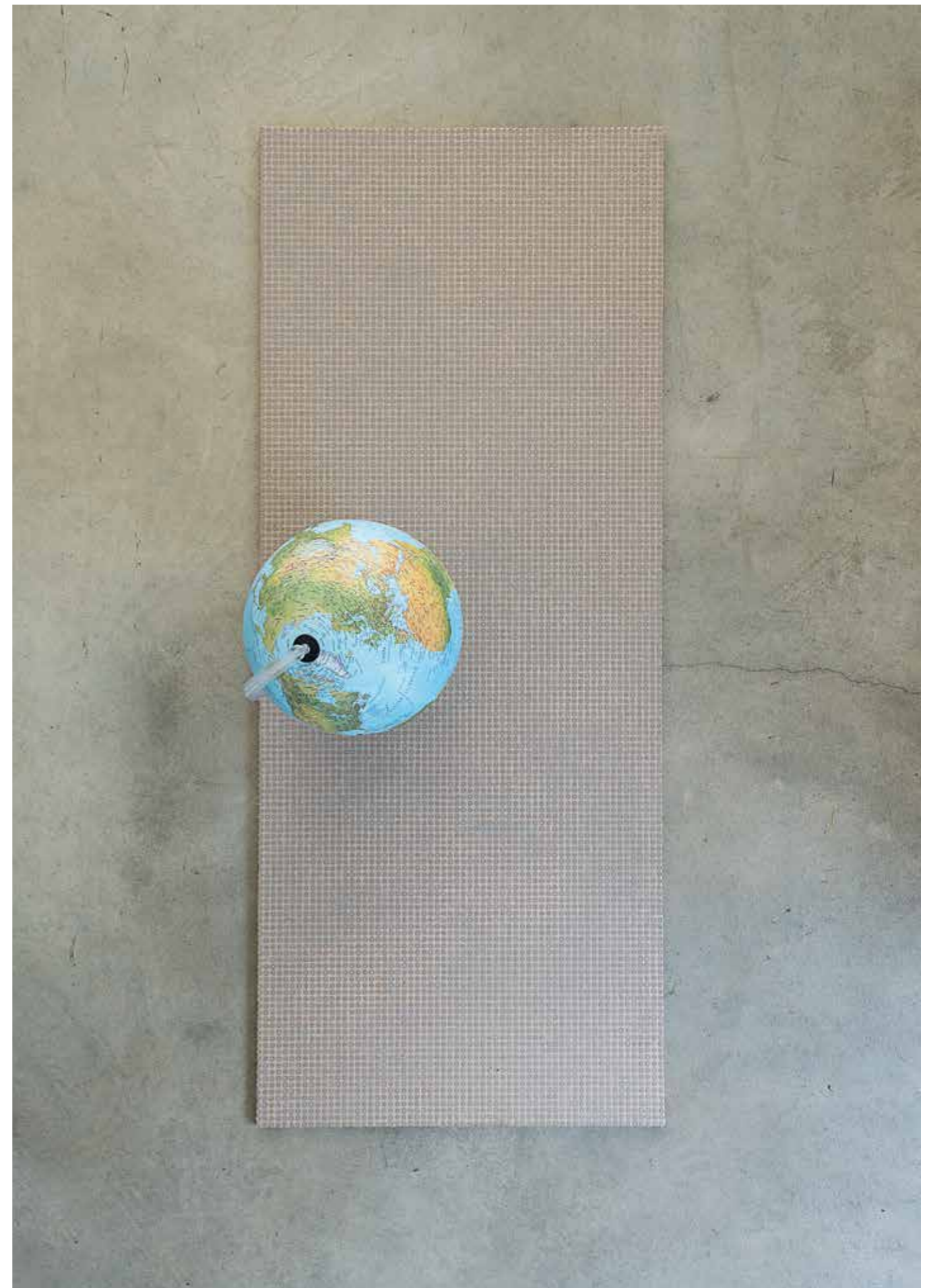

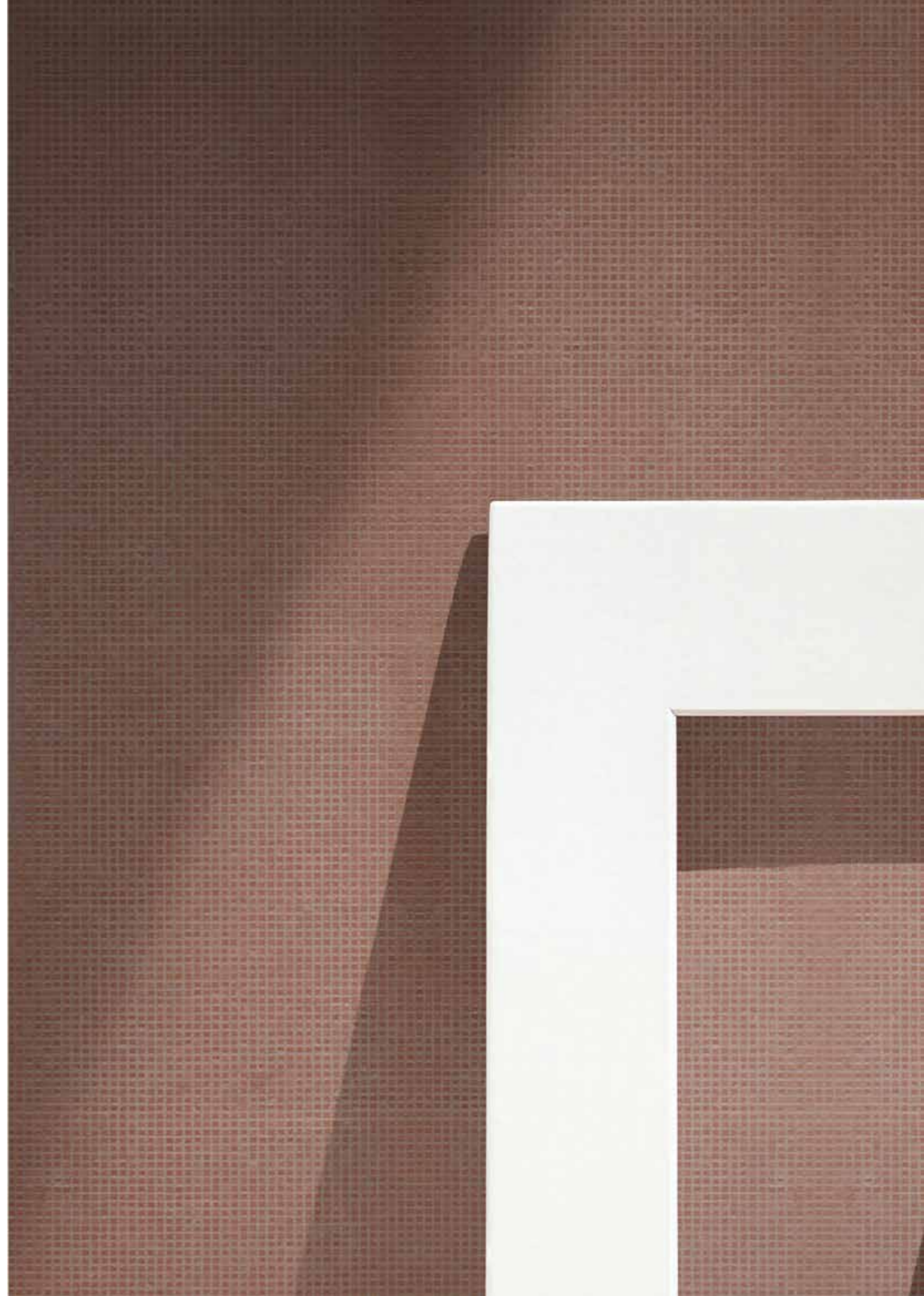
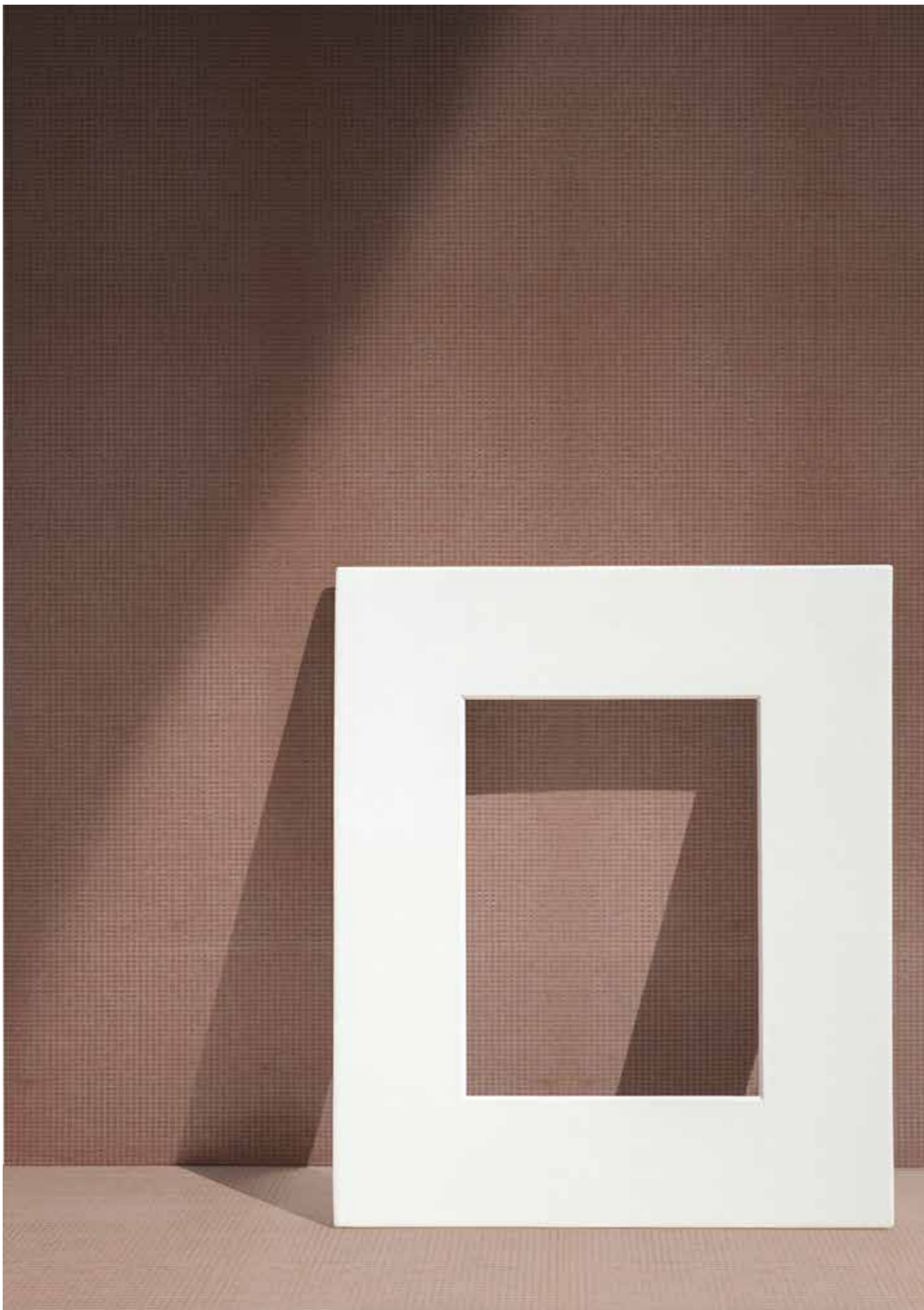





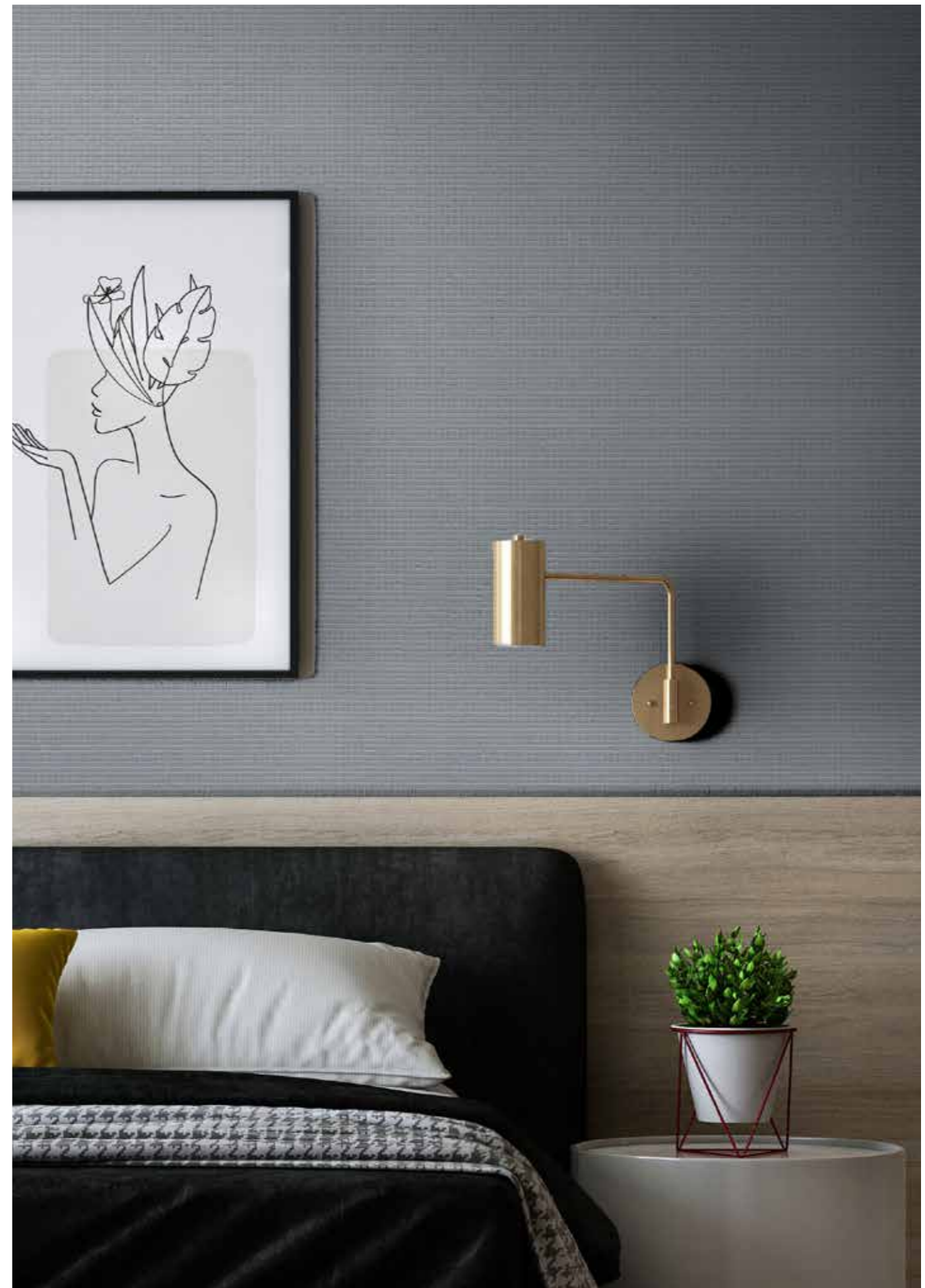

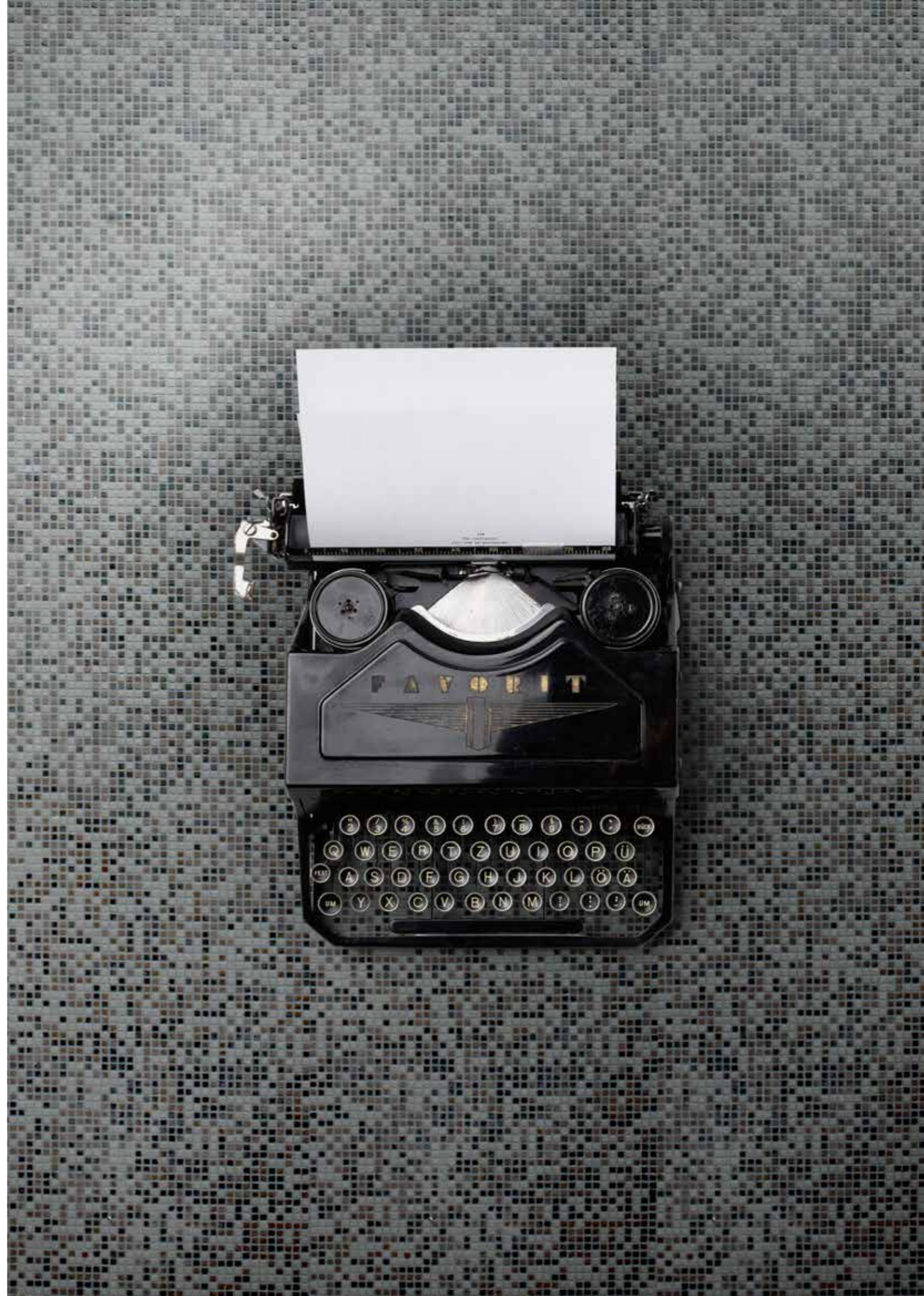

Micromosaics

Matt



Micromosaics

Mix



Glossy



Micromosaics

Alea

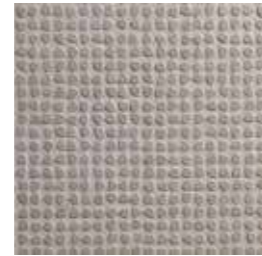
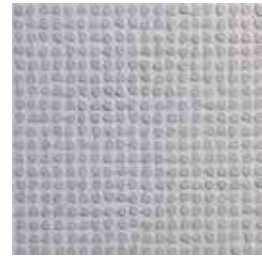
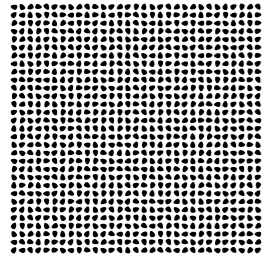

Alea Penna
30 x 30 cm
12 x 12 inches

ALP10
Alea Penna
Bone

ALP60
Alea Penna
Clay

ALP70
Alea Penna
Smoke

ALP167
Alea Mix
Penna

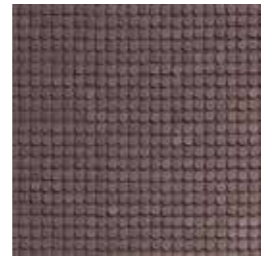
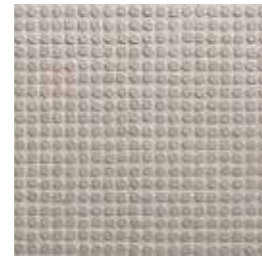
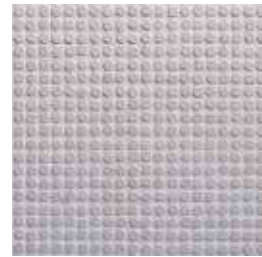
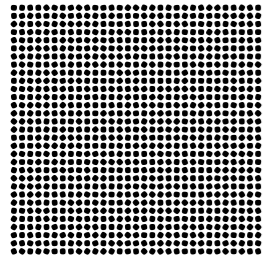

Alea Quadro
30 x 30 cm
12 x 12 inches

ALQ10
Alea Quadro
Bone

ALQ60
Alea Quadro
Clay

ALQ70
Alea Quadro
Smoke

ALQ167
Alea Mix
Quadro

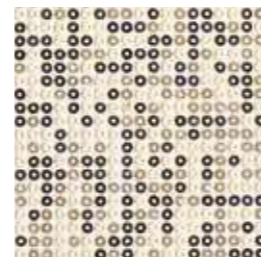
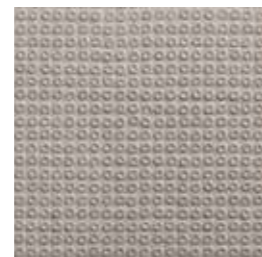
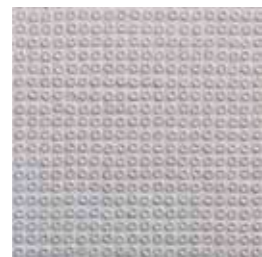
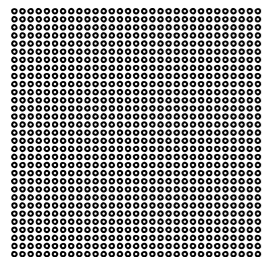

Alea Tondo
30 x 30 cm
12 x 12 inches

ALT10
Alea Tondo
Bone

ALT60
Alea Tondo
Clay

ALT70
Alea Tondo
Smoke

ALT167
Alea Mix
Tondo

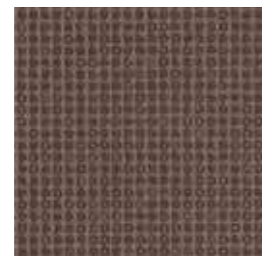
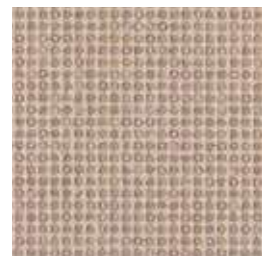

ALM100
Alea Mix
Bone

ALM600
Alea Mix
Clay

ALM700
Alea Mix
Smoke

Micromosaics

Micro-brick

Line

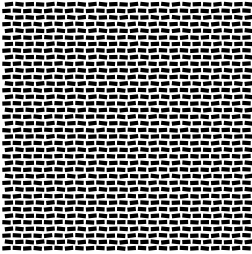

Micro-brick Line
30 x 30 cm
12 x 12 inches



MBL10
Micro-brick Line
White

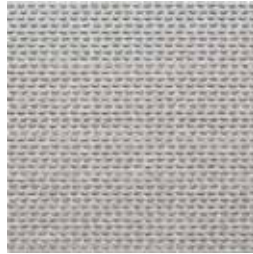

MBL30
Micro-brick Line
Ice

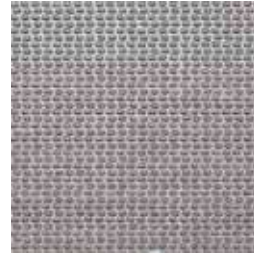

MBL50
Micro-brick Line
Mud



MBL80
Micro-brick Line
Coffee

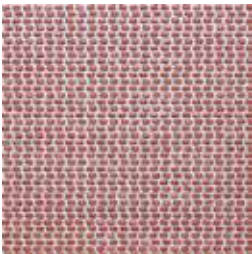

MBL90
Micro-brick Line
Red

Ring

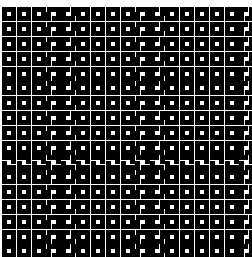

Micro-brick Ring
30 x 30 cm
12 x 12 inches



MBR10
Micro-brick Ring
White



MBR30
Micro-brick Ring
Ice



MBR50
Micro-brick Ring
Mud



MBR80
Micro-brick Ring
Coffee



MBR90
Micro-brick Ring
Red

Micromosaics Micro-brick

Nod

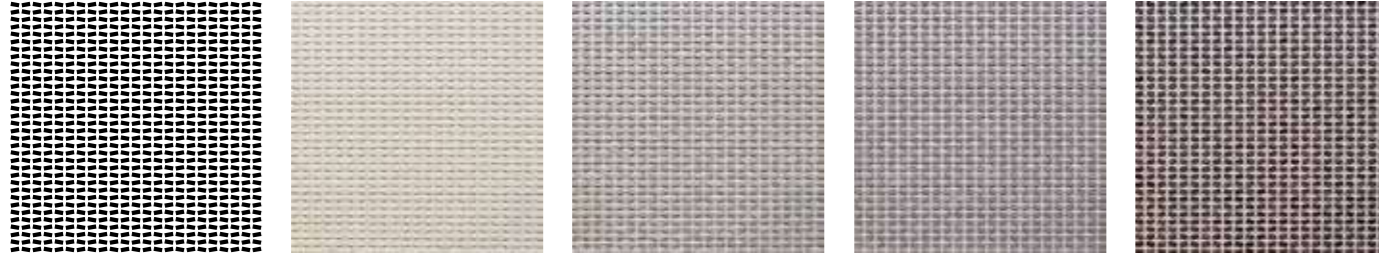

Micro-brick Nod
30 x 30 cm
12 x 12 inches

MBN10
Micro-brick Nod
White

MBN30
Micro-brick Nod
Ice

MBN50
Micro-brick Nod
Mud

MBN80
Micro-brick Nod
Coffee

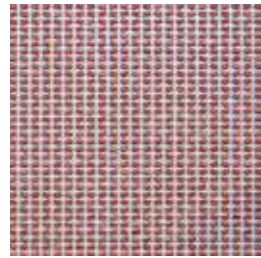

MBN90
Micro-brick Nod
Red

Cross



Micro-brick Cross
30 x 30 cm
12 x 12 inches

MBC10
Micro-brick Cross
White

MBC30
Micro-brick Cross
Ice

MBC50
Micro-brick Cross
Mud

MBC80
Micro-brick Cross
Coffee

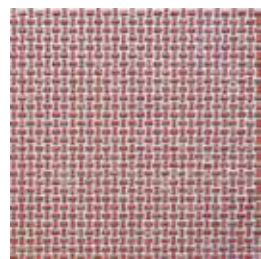

MBC90
Micro-brick Cross
Red

Micromosaics Micro-brick

Pavement



Micro-brick Pavement
30 x 30 cm
12 x 12 inches

MBP10
Micro-brick Pavement
White

MBP30
Micro-brick Pavement
Ice

MBP50
Micro-brick Pavement
Mud

MBP80
Micro-brick Pavement
Coffee



MBP90
Micro-brick Pavement
Red

3D Forms - Cross handmade

Caratteristiche tecniche
Technical features



PIASTRELLE DA RIVESTIMENTO IN PASTA BIANCA
WHITE-BODY WALL TILES



ISO 10545/3 - ASSORBIMENTO ACQUA
ISO 10545/3 - WATER ABSORPTION
> 10%



ISO 10545/13 - RESISTENZA ALL'ATTACCO CHIMICO
ISO 10545/13 - RESISTANCE TO ACIDS AND ALKALIS
Conforme | Compliant



ISO 10545/11 - RESISTENZA AL CAVILLO
ISO 10545/11 - GLAZE CRAZING RESISTANCE
Resistente | Resistance

3D Forms - Fluted



PIASTRELLE DA RIVESTIMENTO IN PASTA BIANCA
WHITE-BODY WALL TILES



ISO 10545/2 - DIMENSIONI
ISO 10545/2 - SIZES
Conforme | Compliant



ISO 10545/3 - ASSORBIMENTO ACQUA
ISO 10545/3 - WATER ABSORPTION
> 10%



ISO 10545/4 - RESISTENZA ALLA FLESSIONE
ISO 10545/4 - MODULUS OF RUPTURE
Conforme | Compliant



ISO 10545/11 - RESISTENZA AL CAVILLO
ISO 10545/11 - GLAZE CRAZING RESISTANCE
Resistente | Resistant



ISO 10545/13 - RESISTENZA ALL'ATTACCO CHIMICO
ISO 10545/13 - CHEMICAL RESISTANCE
Conforme | Compliant

Typic

Caratteristiche tecniche
Technical features



PIASTRELLE DA RIVESTIMENTO IN PASTA BIANCA
WHITE-BODY WALL TILES



ISO 10545/2 - DIMENSIONI
ISO 10545/2 - SIZES
Conforme | Compliant



ISO 10545/3 - ASSORBIMENTO ACQUA
ISO 10545/3 - WATER ABSORPTION
> 10%



ISO 10545/4 - RESISTENZA ALLA FLESSIONE
ISO 10545/4 - MODULUS OF RUPTURE
Conforme | Compliant













ISO 10545/11 - RESISTENZA AL CAVILLO
ISO 10545/11 - GLAZE CRAZING RESISTANCE
Resistente | Resistant



ISO 10545/13 - RESISTENZA ALL'ATTACCO CHIMICO
ISO 10545/13 - CHEMICAL RESISTANCE
Conforme | Compliant









Cluster

Caratteristiche tecniche
Technical features

	<p>GRES PORCELLANATO PORCELAIN STONEWARE</p> <p>ISO 10545/2 - DIMENSIONI ISO 10545/2 - SIZES Conforme Compliant</p>		<p>RESISTENZA ALLO SCIVOLAMENTO SKID RESISTANCE Disponibile su richiesta Available on request</p>
	<p>ISO 10545/3 - ASSORBIMENTO ACQUA ISO 10545/3 - WATER ABSORPTION < 0,5%</p>		<p>10545/12 - RESISTENZA AL GELO ISO 10545/12 - FROST RESISTANCE Conforme Compliant</p>
	<p>ISO 10545/4 - MODULO DI ROTTURA ISO 10545/4 - MODULUS OF RUPTURE Conforme Compliant</p>		<p>ISO 10545/13 - RESISTENZA ALL'ATTACCO CHIMICO ISO 10545/13 - CHEMICAL RESISTANCE Da GLA a GLB From GLA to GLB Da GHA a GHB From GHA to GHB GA</p>
	<p>ISO 10545/4 - RESISTENZA ALLA FLESSIONE ISO 10545/4 - THERMAL EXPANSION COEFFICIENT Conforme Compliant</p>		<p>ISO 10545/14 - RESISTENZA ALLE MACCHIE ISO 10545/14 - STAIN RESISTANCE Classe 3 min Minimum Class 3 Conforme Compliant</p>
	<p>ISO 10545/9 - RESISTENZA AGLI SBALZI TERMICI ISO 10545/9 - THERMAL SHOCK RESISTANCE Resistente - Nessuna alterazione visibile Resistant - No visible alteration</p>		<p>RESISTENZA DEI COLORI ALLA LUCE COLOR RESISTANCE TO LIGHT NESSUNA VARIAZIONE - NO CHANGE OF COLOURS</p>









Joint

Caratteristiche tecniche
Technical features

	<p>GRES PORCELLANATO PORCELAIN STONEWARE</p> <p>ISO 10545/2 - DIMENSIONI ISO 10545/2 - SIZES Conforme Compliant</p>		<p>ISO 10545/12 - RESISTENZA AL GELO ISO 10545/12 - FROST RESISTANCE Resistente - Resistant</p>
	<p>ISO 10545/3 - ASSORBIMENTO DELL'ACQUA ISO 10545/3 - WATER ABSORPTION < 0,5%</p>		<p>ISO 10545/13 - RESISTENZA ALL'ATTACCO CHIMICO ISO 10545/13 - CHEMICAL RESISTANCE Da GLA a GLB From GLA to GLB Da GHA a GHB From GHA to GHB GA</p>
	<p>ISO 10545/9 - RESISTENZA AGLI SBALZI TERMICI ISO 10545/9 - THERMAL SHOCK RESISTANCE Resistente - Nessuna alterazione visibile Resistant - No visible alteration</p>		<p>ISO 10545/14 - RESISTENZA ALLE MACCHIE ISO 10545/14 - STAIN RESISTANCE Classe 3 min Minimum class 3 Conforme Compliant</p>
	<p>RESISTENZA ALLO SCIVOLAMENTO SLIP RESISTANCE DIN 51130 R10 ANSI A137-1 DCOF > 0,42</p>		<p>RESISTENZA DEI COLORI ALLA LUCE COLOR RESISTANCE TO LIGHT NESSUNA VARIAZIONE - NO CHANGE OF COLOURS</p>





Familiar

Caratteristiche tecniche
Technical features

	GRES PORCELLANATO PORCELAIN STONEWARE		ISO 10545/12 - RESISTENZA AL GELO ISO 10545/12 - FROST RESISTANCE Resistente - Nessuna alterazione visibile Resistant - No visible alteration
	ISO 10545/2 - DIMENSIONI ISO 10545/2 - SIZES Conforme / Compliant		ISO 10545/13 - RESISTENZA ALL'ATTACCO CHIMICO ISO 10545/13 - CHEMICAL RESISTANCE Da GLA a GLB From GLA to GLB Da GHA a GHB From GHA to GHB GA
	ISO 10545/3 - ASSORBIMENTO ACQUA ISO 10545/3 - WATER ABSORPTION < 0,5%		ISO 10545/14 - RESISTENZA ALLE MACCHIE ISO 10545/14 - STAIN RESISTANCE Classe 3 min Minimum class 3 Conforme Compliant
	ISO 10545/9 - RESISTENZA AGLI SBALZI TERMICI ISO 10545/9 - THERMAL SHOCK RESISTANCE Resistente - Nessuna alterazione visibile Resistant - No visible alteration		RESISTENZA DEI COLORI ALLA LUCE COLORS RESISTANCE TO LIGHT NESSUNA VARIAZIONE - NO CHANGE OF COLORS
	RESISTENZA ALLO SCIVOLAMENTO SLIP RESISTANCE DIN 51130 R10 ANSI A137-1 DCOF > 0,42		

Perlinato

Caratteristiche tecniche
Technical features









	BICOTTURA IN PASTA BIANCA WHITE BODY DOUBLE FIRING		ISO 10545/14 - RESISTENZA ALLE MACCHIE ISO 10545/14 - STAIN RESISTANCE Classe 3 min Minimum class 3 Conforme Compliant
	ISO 10545/2 - DIMENSIONI ISO 10545/2 - SIZES Conforme / Compliant		RESISTENZA DEI COLORI ALLA LUCE COLORS RESISTANCE TO LIGHT NESSUNA VARIAZIONE - NO CHANGE OF COLORS
	ISO 10545/3 - ASSORBIMENTO ACQUA ISO 10545/3 - WATER ABSORPTION > 10%		
	ISO 10545/9 - RESISTENZA AGLI SBALZI TERMICI ISO 10545/9 - THERMAL SHOCK RESISTANCE Resistente - Nessuna alterazione visibile Resistant - No visible alteration		

I pezzi ceramici contenuti in queste scatole sono il risultato di un prodotto artigianale fabbricato a mano e si caratterizzano per l'esclusività e le piccole variazioni di continuità, tramatura e calibro tra i vari pezzi. Eventuali leggeri difetti superficiali sono da considerarsi parte integrante dell'artigianalità del prodotto. I toni presenti all'interno delle campionature sono da ritenersi indicativi e possono variare leggermente tra una produzione e l'altra. Non si accetteranno reclami una volta posato il prodotto.

The exclusive ceramic products contained in these boxes are handmade and characterized by a slight variation in texture and calibre among different pieces. Any slight surface defects are possible and are considered an inherent characteristic of this handmade product. The shades of samples are indicative as they may vary slightly across production lots. No claims will be accepted once the product has been laid.

Microtiles

Caratteristiche tecniche
Technical features

	GRES PORCELLANATO NON SMALTATO UNGLAZED PORCELAIN STONEWARE Matt and Mix		ISO 10545/12 - RESISTENZA AL GELO ISO 10545/12 - FROST RESISTANCE Resistente - Resistant
	ISO 10545/2 - DIMENSIONI ISO 10545/2 - SIZES Conforme / Compliant		ISO 10545/13 - RESISTENZA ALL'ATTACCO CHIMICO ISO 10545/13 - CHEMICAL RESISTANCE Da ULA a ULB From ULA to ULB Da UHA a UHB From UHA to UHB UA
	ISO 10545/3 - ASSORBIMENTO ACQUA ISO 10545/3 - WATER ABSORPTION < 0,5%		ISO 10545/14 - RESISTENZA ALLE MACCHIE ISO 10545/14 - STAIN RESISTANCE Classe 3 min / Minimum class 3 Conforme Compliant
	ISO 10545/9 - RESISTENZA AGLI SBALZI TERMICI ISO 10545/9 - THERMAL SHOCK RESISTANCE Resistente - Nessuna alterazione visibile Resistant - No visible alteration		RESISTENZA DEI COLORI ALLA LUCE COLORS RESISTANCE TO LIGHT NESSUNA VARIAZIONE - NO CHANGE OF COLORS
	RESISTENZA ALLO SCIVOLAMENTO SLIP RESISTANCE DIN 51130 R10 ANSI A137-1 DCOF > 0,42		

AVVERTENZA NOTICE

Per Microtiles Glaze e Mix Glaze è sconsigliata la posa a pavimento.
Floor laying is not recommended for Microtiles Glaze and Mix Glaze families.

Micromosaics

Caratteristiche tecniche
Technical features

	GRES PORCELLANATO opachi e miscele PORCELAIN STONEWARE matt and mix		RESISTENZA ALL'ATTACCO CHIMICO RESISTANCE TO ACIDS AND ALKALIS Da ULA a ULB From ULA to ULB Da UHA a UHB From UHA to UHB UA
	GRES PORCELLANATO SMALTATO lucidi GLAZED PORCELAIN STONEWARE glossy		RESISTENZA DEI COLORI ALLA LUCE COLORS RESISTANCE TO LIGHT NESSUNA VARIAZIONE - NO CHANGE OF COLORS
	ASSORBIMENTO ACQUA WATER ABSORPTION $\leq 0,3\%$ $\leq 0,26\%$ - solo White / only White Un basso assorbimento d'acqua garantisce l'utilizzo dei nostri materiali anche per uso esterno. Low water absorption allows our materials to be used also outdoor.		RESISTENZA ALLO SCIVOLAMENTO SKID RESISTANCE MATT DIN 51130 R11 ANSI A137-1 DCOF > 0,42
	RESISTENZA AL GELO FROST RESISTANCE Resistente - Resistant		

Le soluzioni visive per l'arredamento Micropapers vengono realizzate interamente in Italia e rispondono alle normative europee per la salute e la tutela dell'ambiente.

Il supporto é formato da due strati.

Il lato superiore é in vinile, il lato stampabile, e nel retro uno strato di TNT (tessuto non tessuto) che conferisce le seguenti caratteristiche al prodotto:

- Inassorbente e inodore;
- Lavabile con acqua e sapone neutro;
- Ignifugo;
- Elevata stabilità dimensionale durante le fasi di applicazione e asciugatura del prodotto;
- Facilità di montaggio e di eventuale rimozione del prodotto.

Per l'applicazione del materiale vinilico Micropapers si richiede un sottofondo idoneo (liscio, poroso e trattato con un primer aggrappante) per evitare possibili contestazioni.

Mapei. Glicovil

DESCRIZIONE DEL PRODOTTO

Adesivo a base di amidi modificati per rivestimenti murali di ogni tipo.

CAMPI D'IMPIEGO

Glicovil è idoneo per l'incollaggio a parete di rivestimenti murali di ogni tipo su supporto in carta su tutti i sottofondi assorbenti usati in edilizia come ad esempio:

- intonaci di cemento;
- malta bastarda;
- gesso, gesso cartonato.

CARATTERISTICHE TECNICHE

Glicovil è un adesivo a base di amidi modificati, a spalmatura semplice che si presenta sotto forma di piccole scaglie bianche, facilmente disperdibili in acqua. Glicovil è facilmente applicabile a rullo o a spatola. Glicovil non è infiammabile e non contiene sostanze tossiche; pertanto può essere immagazzinato senza particolari accorgimenti e può essere utilizzato senza pericoli per la salute.

PREPARAZIONE DELL'ADESIVO.

Agitare l'acqua con trapano a media velocità versare velocemente il contenuto del sacchetto.

Diluire Glicovil con circa 5-7 litri di acqua (variabile a seconda della grammatura del rivestimento).

Lasciare riposare per 5 minuti e poi agitare nuovamente.

Glicovil è pronto in 10-15 minuti.

Dosaggio: 4-5 litri - Resa: 4-5 rotoli

Micropapers. istruzioni di montaggio

Per L'applicazione del materiale vinilico Micropapers si richiede un sottofondo idoneo (liscio, poroso e trattato con un primer aggrappante) per evitare possibili contestazioni.

1 Controllo primo rullo

Misurare il primo rullo per assicurarsi che esso sia di 10 cm più lungo rispetto all'altezza della parete. Questa abbondanza è necessaria a compensare eventuali fuori piombo della parete, e verrà tagliata una volta posata la carta.

2 Tracciare le guide

Con le istruzioni di posa davanti tracciate sul muro la fine di ogni rullo con una matita. Alle due estremità, sinistra e destra, deve rimanere un po' di abbondanza per compensare un eventuale fuori piombo della parete.

3 Preparare la colla

La colla è calcolata appositamente per la superficie da rivestire. Sulla busta è indicata la quantità d'acqua con cui diluire la colla. Versare la colla in un recipiente e poi aggiungere l'acqua. Mescolate in modo continuo per evitare il formarsi di grumi. Per un miglior risultato preparare 24h prima dell'utilizzo.

4 Applicare la colla

Utilizzando un rullo, stendete la colla sul muro in modo omogeneo per la larghezza di un telo.

5 Stendere i teli

Iniziando dal secondo (2°) telo, stendete i teli successivi, dall'alto verso il basso, utilizzando l'apposita spatola da tappeziere avendo cura di non rovinare la carta. Al termine del montaggio, tagliare le eccedenze utilizzando un cutter.

6 Pulire la parete

Con una spugna non abrasiva, ripulite da eventuali residui di colla con acqua.

The visual solutions for the Micropapers. furnishings are carried out entirely in Italy and meet the European standards for health and environmental protection.

The support where the graphics' subjects are printed is a vinyl with a layer of TNT (non-woven fabric) on the back that confers the following characteristics to the product:

- Non-absorbent and odourless;
- Washable with mild soap and water;
- Fire resistant;
- High dimensional stability during the application and drying stages of the product;
- Extremely easy to put up and take down if necessary.

For the application of the vinyl material Micropapers a suitable substrate is required (smooth, porous and treated with a clinging primer) to avoid possible disputes.

Mapei. Glicovil

PRODUCT DESCRIPTION

Modified starch-based adhesive for all types of wall coatings.

WHERE TO USE

Glicovil is suitable for bonding all kinds of paper-backed coating materials on walls on all absorbent substrates normally used in the building industry, such as:

- cement render;
- lime-mortar render;
- gypsum and plasterboard.

TECHNICAL SPECIFICATIONS

Glicovil is a modified starch-based adhesive which is easy to apply. It is available in the form of small, white flakes which dissolve quickly in water.

Glicovil is easy to apply using a roller or trowel.

Glicovil is not inflammable and does not contain hazardous substances. No special precautions need to be taken for storage purposes, and it may be used without any health risk.

PREPARATION OF THE ADHESIVE.

Mix the water with a medium-speed drill while quickly adding the contents of the sack.

Dilute Glicovil with approximately 5 to 7 lt. of water (the amount varies according to the weight of the coating).

Let the product stand for 5 minutes and then mix again.

Glicovil is ready in 10-15 minutes.

Dosage: 4-5 litres - Yield: 4-5 rolls

Micropapers. installation instructions

To avoid any possible complaints, a proper background base is required to install Micropapers vinyl wall coverings (smooth, porous and treated with clinging primer).

1 Check the first roll

Measure the first roll to check 5 cm, that it is 10 cm longer than the height of the wall. This excess is necessary to compensate if the wall is out of plumb, and will be trimmed once the paper has been applied.

2 Mark guides

With the application instructions in front of you, use a pencil to mark the end of each roll on the wall. There should be a little excess paper at the two ends – left and right – to compensate if the wall is out of plumb.

3 Preparing the adhesive

The quantity of adhesive has been specially calculated for the surface to be covered. The amount of water needed to dilute the adhesive is given on the pack. Pour the adhesive into a container and then add the water. Stir continuously to prevent the formation of lumps. For a better result, prepare the adhesive 24H before its use.

4 Applying the adhesive

Using a roller, spread the adhesive evenly onto the wall for the width of one sheet.

5 Applying the sheets

Starting from the second (2nd) sheet, apply the subsequent sheets from top to bottom, using the papering spatula and taking care not to ruin the paper. After applying all the sheets, use a cutter to trim the excess.

6 Clean the wall

Clean off any excess glue using water and a non-abrasive sponge.

Micromosaics

Consigli per la posa
Laying tips

1. CONTROLLO MATERIALE

Controllare che il materiale sia sufficiente per completare il lavoro. In caso contrario ordinare materiale della stessa partita (stesso tono e produzione).

2. RASATURA DELLA PARETE

Il sottofondo deve essere perfettamente rasato (liscio) e uniforme in quanto il mosaico, avendo dimensioni ridotte, legge anche le più piccole asperità del sottofondo.

3. STESURA DEL PRIMER

Prima di applicare la colla, stendere sulla parete (o pavimento) un Primer scelto tra quelli attualmente in commercio. Tale operazione, rallentando l'indurimento della colla, costante di stendere il collante su di una più ampia superficie (e di utilizzarne una più modesta quantità).

4. STESURA DEL COLLANTE

Preparare il collante e stenderne un primo strato utilizzando la parte liscia della spatola. La quantità deve essere tale da consentire la posa di oltre un metro quadro di materiale. Con una spatola avente una dente di 3 mm di larghezza e 2,5 mm di altezza pettinare con attenzione la colla mediante una doppia spalmatura: sia la superficie da rivestire che il retro del foglio di mosaico.

5. PREPARAZIONE DEL MATERIALE (solo per Micromosaics.)

Per una posa davvero ottimale, si possono eventualmente rifilare i fogli di mosaico asportando/tagliando la fila di cubetti più esterna di ognuno dei quattro lati del modulo (non obbligatorio).

6. POSA DEL MATERIALE

Posare il materiale sfalsando i fogli in modo casuale verificando che la distanza tra i fogli sia la stessa di quella che esiste tra un tassello e l'altro.

7. BATTITURA DEL MATERIALE

Terminata la posa, battere il materiale con la spatola in ferro (e non con il fettazzo in gomma) e massaggiare con le dita i bordi là dove il materiale tende ad alzarsi anche dopo la battitura. Questa importante operazione fa sì che non si legga il modulo del foglio.

IMPORTANTE: Prima di battere il materiale verificare che la colla abbia iniziato ad asciugarsi staccando uno spigolo qualsiasi del foglio di mosaico dal muro. Quando questa operazione diventa più difficoltosa è il momento di iniziare a battere il materiale.

8. REGISTRAZIONE DEL MATERIALE

Ultimata la posa e prima dell'asciugatura della colla regolare, dove serve, la distanza tra le tessere al fine di uniformare tutte le fughe. Questa operazione viene fatta tagliando la rete con un taglierino e muovendo le tessere con un cazzuolino o altro strumento sufficientemente sottile.

9. RIMOZIONE COLLANTE

Eventuali tracce di adesivo presenti sulla superficie del mosaico devono essere rimosse prima del suo completo indurimento utilizzando una spugna inumidita.

10. ASCIUGATURA COLLA

A questo punto lasciare asciugare per 24/48 ore prima della operazione di stuccatura.

11. RIMOZIONE COLLA IN ESUBERO

Prima dell'operazione di stuccatura rimuovere dove serve la colla fuoriuscita dalle fughe.

12. PROTEZIONE DEL MATERIALE (obbligatorio per il colore WHITE)

Su tutti i Micromosaics. opachi e mix (no glossy) prima della stuccatura, è consigliabile la stesura con pennellessa dell'impregnante Fila MP 90. Questo consente, chiudendo qualsiasi porosità, di poter rimuovere lo stucco con facilità.

13. STUCCATURA DEL MATERIALE

Almeno dopo 24 ore dall'applicazione del FILA MP90 utilizzare gli stucchi consigliati andando a stuccare il materiale. Rimuovere lo stucco in eccesso prima che lo stesso si indurisca.

14. PULIZIA DEL MATERIALE

Con una spugna, prima che lo stucco si indurisca, lavare con abbondante acqua il materiale. Ripetere l'operazione più volte fino alla rimozione totale dello stucco dalla superficie delle tessere. Per rimuovere residui di stucco epossidico usare il detergente Fila PS/87, Litonet Gel o Litonet Pro, versare il prodotto puro, lasciare agire 15/20 minuti, strofinare con disco o spugna abrasiva e risciacquare. Nel caso si utilizzasse stucco a base cementizio si consiglia almeno dopo 24 ore dalla stuccatura di utilizzare il detergente acido Deterdek diluito 1:5 in acqua. Versare la soluzione, lasciare agire 5/6 minuti, strofinare con disco color verde o spugna abrasiva e risciacquare. Per la serie Glossy non utilizzare il detergente Fila PS/87 puro perché danneggia lo smalto.

15. MANUTENZIONE

Per la manutenzione ordinaria lavare con il detergente neutro Fila Cleaner diluito 1:200 (1/2 tazzina da caffè in 5 litri di acqua) utilizzando uno straccio umido che andrà sciacquato spesso nella soluzione. Per sporchi più intensi usare il detergente Fila PS/87 diluito. Risciacquando al termine del lavaggio.

Micromosaics

Consigli per la posa
Laying tips

1. CHECK YOUR MATERIAL

Make sure you have enough material to finish the job. If not, order material from the same batch (same tone and production run).

2. SHAVING THE WALL

The foundation must be completely shaved (smooth) and even. Mosaics are small which means they will show up even with the slightest roughness on the surface underneath.

3. APPLYING THE PRIMER

Before applying the glue, apply a primer currently available on sale on the wall (or on the floor). As this delays the hardening, the glue can be applied on a larger surface (and coverage increases consequently).

4. APPLYING THE GLUE

Prepare the glue and apply the first layer, using the smooth part of the spatula. You must use enough to allow the laying of about more than one square metre of material. Use a comb spatula with teeth 3 mm wide and 2,5 mm high to apply the adhesive, spreading two layers: one on the surface to be tiled and one on the back of the mosaic sheet.

5. PREPARING THE MATERIAL (only for Micromosaics.)

For the best fixing, the mosaic sheets can be possibly trimmed by removing/cutting the most external row of cubes in each of the four sides (not mandatory).

6. LAYING THE MOSAICS

Lay the mosaic by casually staggering the pieces, taking care that the distance between sheets is the same as the distance between one mosaic tile and the next.

7. SMOOTHING THE MOSAICS

After laying, smooth the mosaics with the iron spatula (not the rubber scraper) and using your fingers, press the edges of the material where it tends to rise even after smoothing. This important step ensures that you cannot see the join of the sheet.

IMPORTANT: Before tapping the mosaic down, check that the adhesive has begun to set by pulling up any corner of the mosaic sheet from the wall. The time to begin tapping the mosaic is when it starts to become difficult to detach the sheet.

8. FIXING THE MOSAICS

Once laying is complete, and before the adhesive dries, where necessary, adjust the distance between tiles so that all the joins are the same. You should do this by cutting the mesh with a cutter and moving the tiles with a small trowel or other sufficiently fine instruments.

9. REMOVING THE GLUE

Any traces of glue left on the surface of the mosaic must be removed before it dries completely, using a damp sponge.

10. DRYING THE GLUE

Before grouting, you have to leave the glue to dry for 24-48 hours.

11. REMOVING EXCESS GLUE

Before proceeding with the grouting, remove any excess glue from the joints.

12. PROTECTING THE MOSAICS (mandatory for WHITE material)

On all opaque and mixed (no glossy) Micromosaics, it is advisable to apply Fila MP 90 impregnating agent with a brush before grouting. This closes any porosity and makes it easy to remove the filler.

13. GROUTING

Wait at least 24 hours after the application of FILA MP90, then use the recommended grouts to grout the mosaics. Remove any excess grout before it hardens.

14. CLEANING THE MOSAICS

Using a sponge, wash the mosaics thoroughly with water before the grout hardens. Repeat this operation several times until all the grout has been removed from the mosaic surface. Use Fila PS/87, Litonet Gel or Litonet Pro detergent to remove any remaining residues of epoxy grout. Pour the product on undiluted, leave it to work for 15-20 minutes, and then remove it with a disc or abrasive sponge before rinsing again. If you are using a cement-based grout, wait at least 24 hours after grouting before using Deterdek acid detergent diluted 1:5 in water. Pour the diluted solution on, leave it to work for 5-6 minutes, then rub off with a green disc or an abrasive sponge before rinsing again. Do not use undiluted Fila PS/87 detergents on Glossy series surfaces, since they can damage the glaze.

15. MAINTENANCE

For normal cleaning purposes wash the surface down with Fila Cleaner neutral detergent diluted to a ratio of 1:200 (1/2 a coffee cup to 5 litres of water) using a damp cloth and rinsing the cloth frequently in the solution. For tougher dirt use diluted Fila PS/87 detergents. Always rinse down after washing.

Product design and Photography:
Roberto Cicchinè
D-Segno Studio

Rendering 3D: Reality
Thanks to: Sbizzurà, Design? Studio
Associato, Eusebi Arredamenti,
Very Simple Kitchen,
Fam. Malavolta Roberto
Fam. Augello Luciano
Ristorante "La Magnana"
Koinema società Coop.Sociale
Radice Quadrata, unopervolta, Mercatino
Usato (San Benedetto del Tronto),
Trullo "Resolana" Castellana a Grotte (BA)
Lab36, M+T architetti - Uliveus
Prospero Ristorante, Lo Studio,
Koinema - Società Coop. Sociale,
SSAM small artisan manufactures
'Contekst Interior Architects'
'Evenbeeld'.

Printed in March 2023
All rights reserved ©

Micro. is a brand of
Terratinta Group Srl SB

Via Viazza Il Tronco, 45
41042 Fiorano Modenese MO
ITALY

+39 0536 911408
www.terratintagroup.com

TERRATINTA
group



CHANGE
TOGETHER



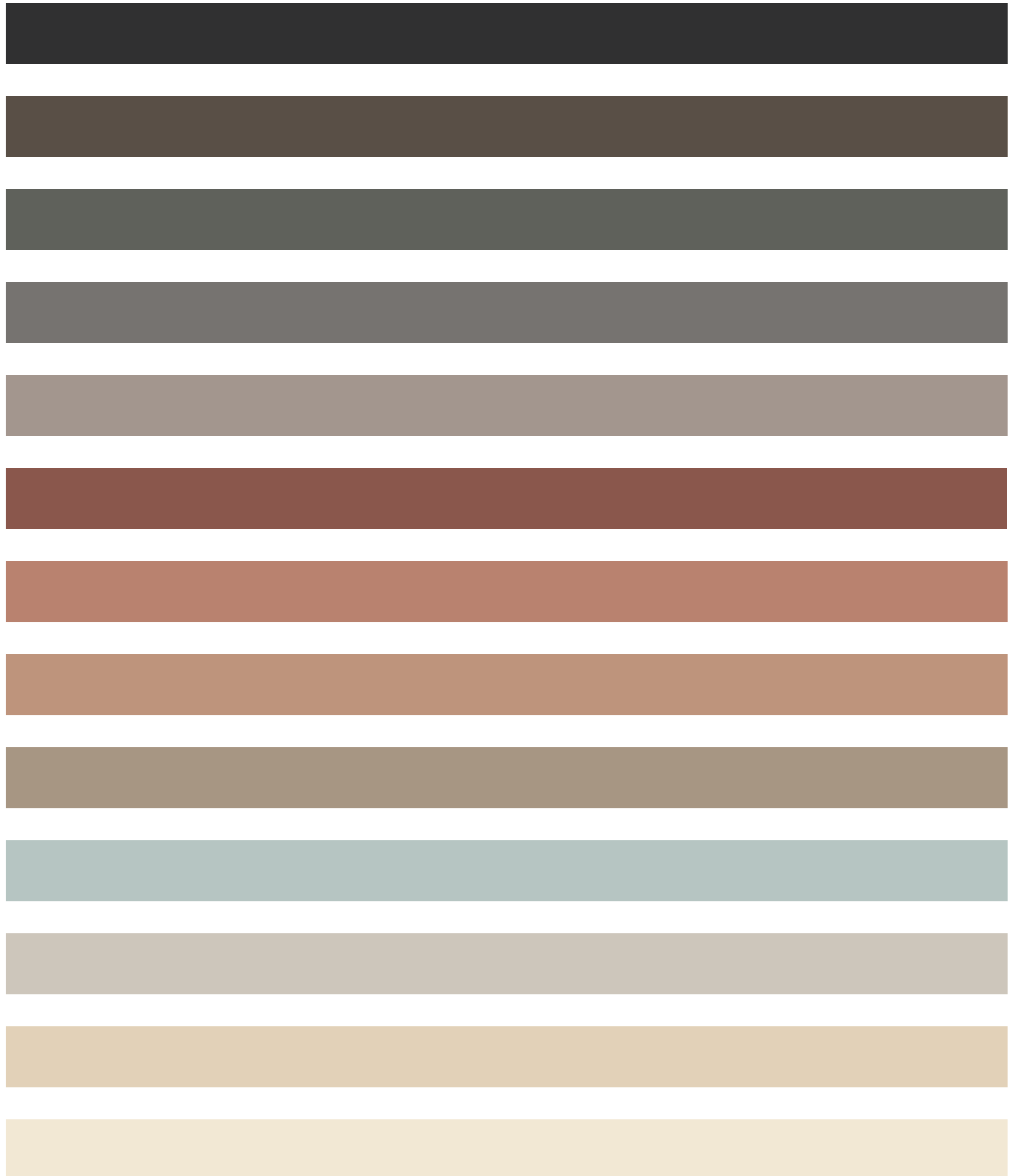

Micro.