

INSTRUCTIONS AND PARTS MANUAL

CW-5AX CIRCLE WELDER

Please record your equipment identification information below for future reference. This information can be found on your machine nameplate.

Model Number _____

Serial Number _____

Date of Purchase _____

Whenever you request replacement parts or information on this equipment, always supply the information you have recorded above.

LIT-CW-5AX-IPM-0813

Bug-O Systems is guided by honesty, integrity and ethics in service to our customers and in all we do.



B U G - O S Y S T E M S

A DIVISION OF WELD TOOLING CORPORATION



280 TECHNOLOGY DRIVE CANONSBURG, PENNSYLVANIA 15317-9564 USA
PHONE: 412-331-1776 <http://www.bugo.com> FAX: 412-331-0383

SAFETY

PROTECT YOURSELF AND OTHERS FROM SERIOUS INJURY OR DEATH. KEEP CHILDREN AWAY. BE SURE THAT ALL INSTALLATION, OPERATION, MAINTENANCE AND REPAIR PROCEDURES ARE PERFORMED ONLY BY QUALIFIED INDIVIDUALS.



ELECTRIC SHOCK can kill.

- 1) The equipment is not waterproof. Using the unit in a wet environment may result in serious injury. Do not touch equipment when wet or standing in a wet location.
- 2) The unused connectors have power on them. Always keep the unused connectors covered with the supplied protective panels. Operation of the machine without the protective panels may result in injury.
- 3) Never open the equipment without first unplugging the power cord or serious injury may result.
- 4) Verify the customer-supplied power connections are made in accordance with all applicable local and national electrical safety codes. If none exist, use International Electric Code (IEC) 950.
- 5) Never remove or bypass the equipment power cord ground. Verify the equipment is grounded in accordance with all applicable local and national electrical safety codes. If none exist, use International Electric Code (IEC) 950.



EQUIPMENT DAMAGE POSSIBLE.

- 1) Do not plug in the power cord without first verifying the equipment is OFF and the cord input voltage is the same as required by the machine or serious damage may result.
- 2) Always verify both the pinion and wheels are fully engaged before applying power or equipment damage may occur.
- 3) Do not leave the equipment unattended.
- 4) Remove from the worksite and store in a safe location when not in use.



FALLING EQUIPMENT can cause serious personal injury and equipment damage.

Faulty or careless user installation is possible. As a result, never stand or walk underneath equipment.



MOVING PARTS can cause serious injury.

- 1) Never try to stop the pinion from moving except by removing power or by using the STOP control.
- 2) Do not remove any protective panels, covers or guards and operate equipment.

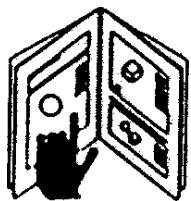

READ INSTRUCTIONS.

Read the instruction manual before installing and using the equipment.

HIGH FREQUENCY WARNINGS

SPECIAL PRECAUTIONS ARE REQUIRED WHEN USING PLASMA, TIG OR ANY WELDING PROCESS THAT USES HIGH FREQUENCY TO STRIKE AN ARC.



WARNING: HIGH FREQUENCY CAN EFFECT MACHINE OPERATION AND THEREFORE, WELD QUALITY.

Read the precautions below before installing and using the equipment.

PRECAUTIONS:

- 1) Some plasma or welding cables are strong sources of high frequency interference. NEVER lay a plasma or welding cable across the controls of the machine.
- 2) Always physically separate the plasma or welding cable leads from the machine cables. For example, the plasma or welding cable leads should NEVER be bundled with a pendant cable or the machine power cord. Maximize the separation between any machine cables and the plasma or welding cables.
- 3) Strictly follow the grounding procedures specified for the plasma or welding unit. NOTE: Some plasma and welding units produce exceptionally large amounts of high frequency noise. They may require a grounding rod be driven into the earth within six feet (2 meters) of the plasma or welding unit to become compatible with an automatic cutting or welding process.
- 4) If the high frequency is produced using a spark gap, adjust the points so the gap is as small as possible. The larger the gap, the higher the voltage and the higher the interference.
- 5) Some plasma or welding units will inject high frequency interference into the AC power line. Use separate power line branches whenever possible to power the plasma or welding source and the machine. Do not plug them into the same outlet box.
- 6) High frequency noise may enter the machine through the plasma or welding supply remote contactor leads. Some plasma and welding sources can produce noise spikes of up to several thousand volts. These sources are not compatible with automated cutting and welding equipment. It is recommended that the remote contactor leads on these plasma or welding sources not be connected to the machine. An alternate solution is to purchase a separate remote contactor isolation box.

CW-5AX CIRCLE WELDER

INSTRUCTIONS AND PARTS MANUAL

TABLE OF CONTENTS

PAGE

5 Introduction / Features / Setup and Operation
7 CWO-3332 Wire Feeder Controls
8 CWO-6210 Rotation Controls
9 Technical Data / Dimensions
10 CW-5AX Circle Welder / Exploded View
11 CW-5AX Circle Welder / Parts List
12 CW-5AX Circle Welder / Wiring Diagram
13 CW-5AX Circle Welder / Wiring Diagram / Electrical Component Chart
14 CWO-1660 CW-5AX Racking System / Exploded View / Parts List
14 CWO-1685 Horizontal Racker / Exploded View / Parts List
15 CWO-3001 Shaft Assembly / Exploded View / Parts List
15 CWO-3004 Cam Shaft and Spacer Assembly / Exploded View / Parts List
16 CWO-3005 5" Cam Assembly / Exploded View / Parts List
16 CWO-3008 Wire Reel Mount Assembly / Exploded View / Parts List
17 CWO-3027 Meter Kit Assembly / Exploded View / Parts List
17 CWO-3027 Meter Kit Assembly / Wiring Diagram
18 CWO-3063 Large Brush Holder and Support / Exploded View / Parts List
18 CWO-3384 P.M. Motor Assembly / Exploded View / Parts List
19 CWO-3199 Housing Assembly / Exploded View / Parts List
20 CWO-3332 GMA Wire Feeder Control / Exploded View / Parts List
21 CWO-3332 GMA Wire Feeder Control / Wiring Diagram / Electrical Component Chart
22 CWO-6210 Rotation Control Box / Exploded View / Parts List
23 CWO-6210 Rotation Control Box / Wiring Diagram / Electrical Component Chart
24 CW-5AX Gun Assemblies (MIG/Flux Cored)
25 CW-5AX Gun Assemblies (Sub Arc)
26 #5 Gun and Cable Assembly / Exploded View / Parts List
27 CWO-3418 Transmission 3.5:1 Assembly / Exploded View / Parts List
27 CWE-1530 Small Brush Holder Assembly / Exploded View / Parts List
27 CWO-3461 Small Retainer Block Assembly / Detail View
28 CWO-3480 CW-5AX Flux Hopper Assembly / Exploded View / Parts List
29 CWO-3690-__ K231 Subarc Gun Assembly / Exploded View / Parts List
30 CWO-3700-__ Subarc Gun Assembly / Exploded View / Parts List
31 CW-5AX Drive Roll Kits
32 Accessories
33 Carriages
34 3-Jaw Expandable Chucks
35-36	.. Setup Instructions For CW-5AX / CB-1P Used In Sprinkler Fabrication
37 Suggested Setup Diagram For CW-5AX / CB-1P Used In Sprinkler Fabrication
38-40	.. Preventive Maintenance / CW-5AX Circle Welder
41 Warranty

INTRODUCTION

The CW-5AX Circle Welder is designed for circular single or multi-pass welding of couplings on sprinkler pipe utilizing MIG or FLUX CORED process, with gas shielding. The CW-5AX is also equipped for multi-pass sub-arc welding of nozzles into vessels or domed heads. For one to twelve inch diameter welds.

FEATURES

- Amperage & wire speed control
- Amperage & voltage meter kit
- Wire feeder with one set of drive rolls
- 1/12 HP P.M. motor and rotational speed control
- 500 AMP Gun & cable assembly
- Gas shielding kit with 120 VAC solenoid valve
- 5/8" (16 mm) gas cup
- Burn back control
- 50 ft. (15 m) power cable
- 50 ft. (15 m) gas shielding hose
- 50 ft. (15 m) weld cable
- Quick disconnects for all cables
- Weld contact switch
- Cold wire inch switch
- Wire direction switch
- Pre and post flow controls
- Wire reel adaptor for 30 lb. (14 kg) spools
- Adjustable vertical and horizontal torch positioning system with torch angle adjustment
- Rise and fall cam assembly with 5" (125 mm) of travel
- Brushes and collector rings for welding current, rated at 500 AMPS 100% duty cycle
- Brushes and collector rings for all controls, eliminates cable and hose wrap

SETUP AND OPERATION

POWER SOURCE:

Use only constant voltage type power sources with this circle welder machine. If using a multiple process power source, be sure that it is set for constant voltage output as per the instructions in the manual for the power source. Set the power source polarity switch or properly connect the electrodes and work leads for the correct electrode polarity.

FIXTURING:

All circle welders have to be fixtured in some manner from the top of the shaft. This may be achieved in one of the following: column & boom, manipulator or carriage & monorail.

GUNS AND CABLES:

All circle welders come equipped with a gun and cable assembly. It is our recommendation that at least once a week the liner be taken out of the cable and soaked overnight in a solvent solution. To keep the wire moving it is also recommended that a felt clip be saturated with a product like Ferro Slick and feed through the incoming tube of the wire feeder at least once a day.

SET-UP AND OPERATION, CONTINUED

ADDITIONAL CABLES:

The circle welders are supplied with the following cables:

1. CWO-3139 50' (15 m) power cable that connects the power source to the cable connector on the top gear of the machine.
2. CWO-3040 50' (15 m) weld cable that connects the lead coming out of the top of the machine using the quick connect connector to your power supply.
3. CWO-9406 50' (15 m) gas shielding hose that connects the gas fitting on the top of the shaft to your shielding gas supply.

WIRE SPEED AND VOLTAGE ADJUSTMENT:

The wire speed control on the front of the CWO-3332 Wire Feed Control box has a dial that is calibrated directly in inches per minute. Set the voltage using the control on the power source.

RISE AND FALL OF THE CAM:

All circle welders are equipped with a rise and fall cam assembly. The cam assembly must be aligned before any other settings can be made. To align the cam rotate the machine so the horizontal rack is parallel to the pipe, then adjust the gun holder so it is perpendicular to the horizontal rack. Position torch tip to top dead center of joint. Loosen the set screws in the brass block on the cam, and rotate the cam to the vertical position as shown. Refasten set screws.

CAM SETTING:

The cam setting is equal to distance "B" subtracted from distance "A".

Example:

Let A=3 and B=2

3-2=1

The cam setting is 1.

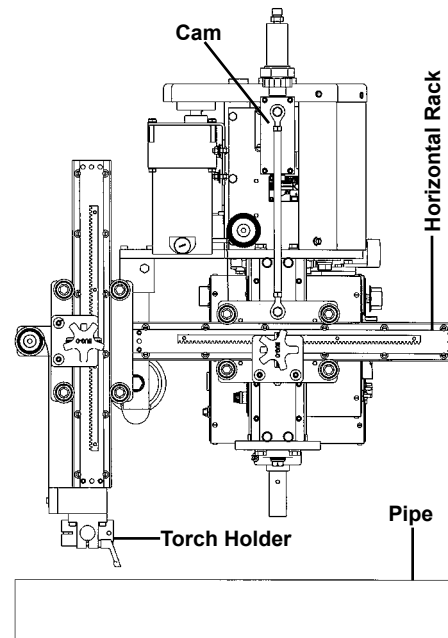
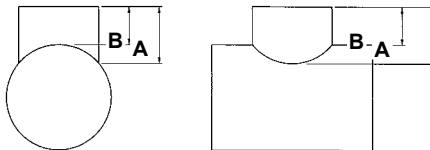

WHEEL ADJUSTMENT:

The CW-5AX Racking System CWO-1660 and the Small Vertical Racker CWO-1685 are equipped with adjustable wheels. Always check these components for proper wheel adjustment before using the machine. The wheels need adjustment if you can cock or wiggle the components out of alignment. The wheels should be snug but not prohibit movement along the path of travel. The wheels with the hex stand offs are adjustable. To adjust the wheels, loosen the hex bolt (A) until the adjustable bushing (B) can be rotated. Correct the wheel alignment by rotating the adjustable bushing (B). Once adjusted, hold the adjustable bushing (B) while tightening the hex bolt (A). Recheck alignment.

MACHINE CONTROLS:

Operational parameters can be set using the two control boxes. Please refer to the sections in this manual entitled CWO-3332 Wire Feeder Control for descriptions of the various welding parameters that are available, as well as CWO-6210 Rotation Control for descriptions of the various speed and directional capabilities.

MAKING A WELD:

1. Position the gun to start position using the CWO-1660 Racking System.
2. Connect the ground cable to the workpiece. The ground cable must make good electrical contact with the work.
3. Position the electrode in the joint. The end of the electrode may be lightly touching the work.
4. With manual/auto switch in the "OFF" position, set rotation direction and speed.
5. Weld process and rotation are both started by throwing the manual/auto switch to auto.
6. Weld process and rotation are stopped by throwing the manual/auto switch to "OFF".

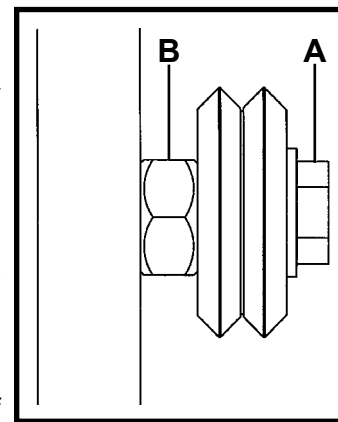

WARNING: When using an open arc process, it is necessary to use correct eye, head and body protection.

CWO-3332 WIRE FEEDER CONTROLS

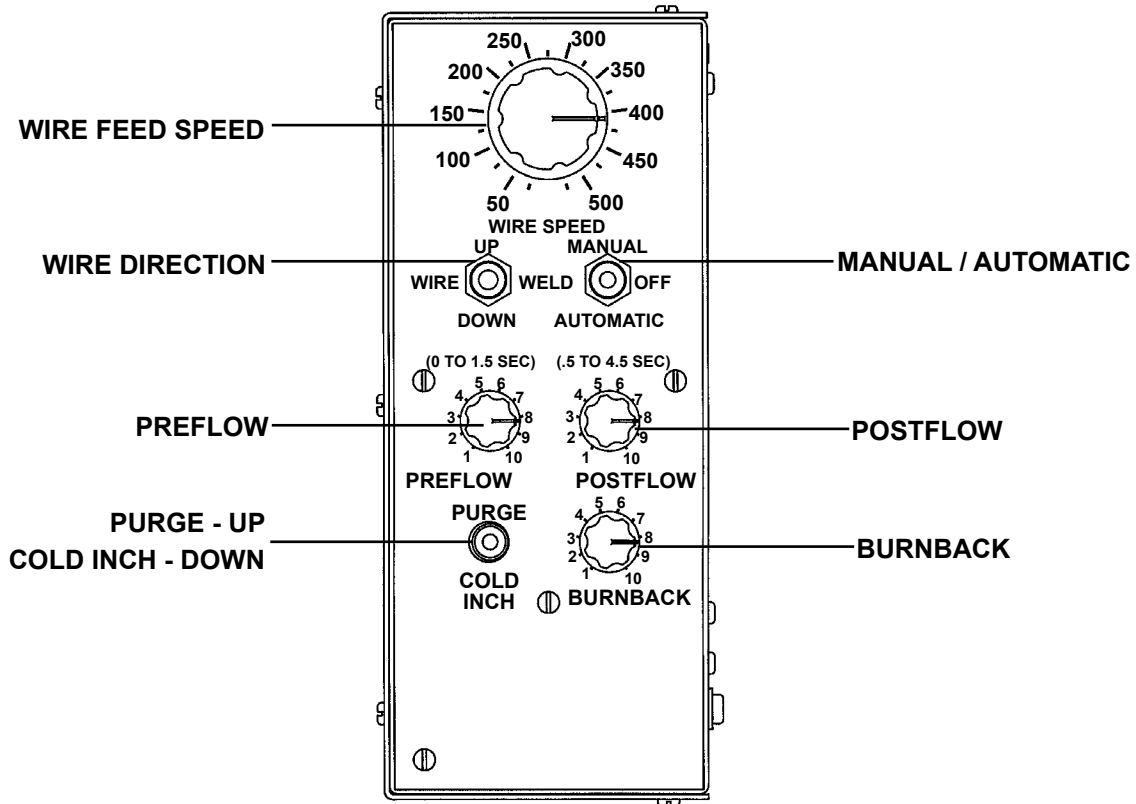

WIRE FEED SPEED CONTROL:

This control sets the feed speed of the wire feeder. Turn the knob to the left for slower speeds and to the right for higher speeds. The control is calibrated. The nameplate shows the wire speed for the given setting of the control.

WIRE DIRECTION:

Controls the direction the wire is being fed through the feeder. **Up** to return wire to the spool. **Down** to feed the wire to the gun in order to weld.

MANUAL / AUTOMATIC:

The manual position allows the operator to rotate the machine without welding to check the wire placement as well as the cam setting. The auto side will start the entire weld operation based on the operators settings, including machine rotation.

PREFLOW CONTROL:

This control, provides flow of shielding gas to the work before the arc is established. The gas solenoid valve is energized immediately when the gun trigger is closed, but the time delay before the wire feeder is energized is adjustable from 0 to 1.5 seconds. Turn the knob to the left for shorter delays and to the right for longer delays.

POSTFLOW CONTROL:

This control provides flow of shielding gas to the work after welding has stopped. Delay for the gas solenoid valve shutoff is adjustable from .5 to 4.5 seconds. Turn the knob to the left for shorter delays and to the right for longer delays.

PURGE - UP / COLD INCH - DOWN SWITCH:

This control provides control of some wire feeder functions without energizing the welding power source. The momentary up position energizes the gas solenoid but not the wire feeder or welding power source. The momentary down position energizes the wire feeder but not the gas solenoid or the welding power source.

BURNBACK CONTROL:

This control provides a precise time delay that allows the wire to be burned off at the end of the weld. This is useful for those applications where higher speed, fine wire feeding is used and there is a tendency for the electrode to overrun at the end of the weld and cause "sticking" in the crater. The delay is adjustable for optimum burnback depending on wire size, process, procedure, etc.

CWO-6210 ROTATION CONTROLS

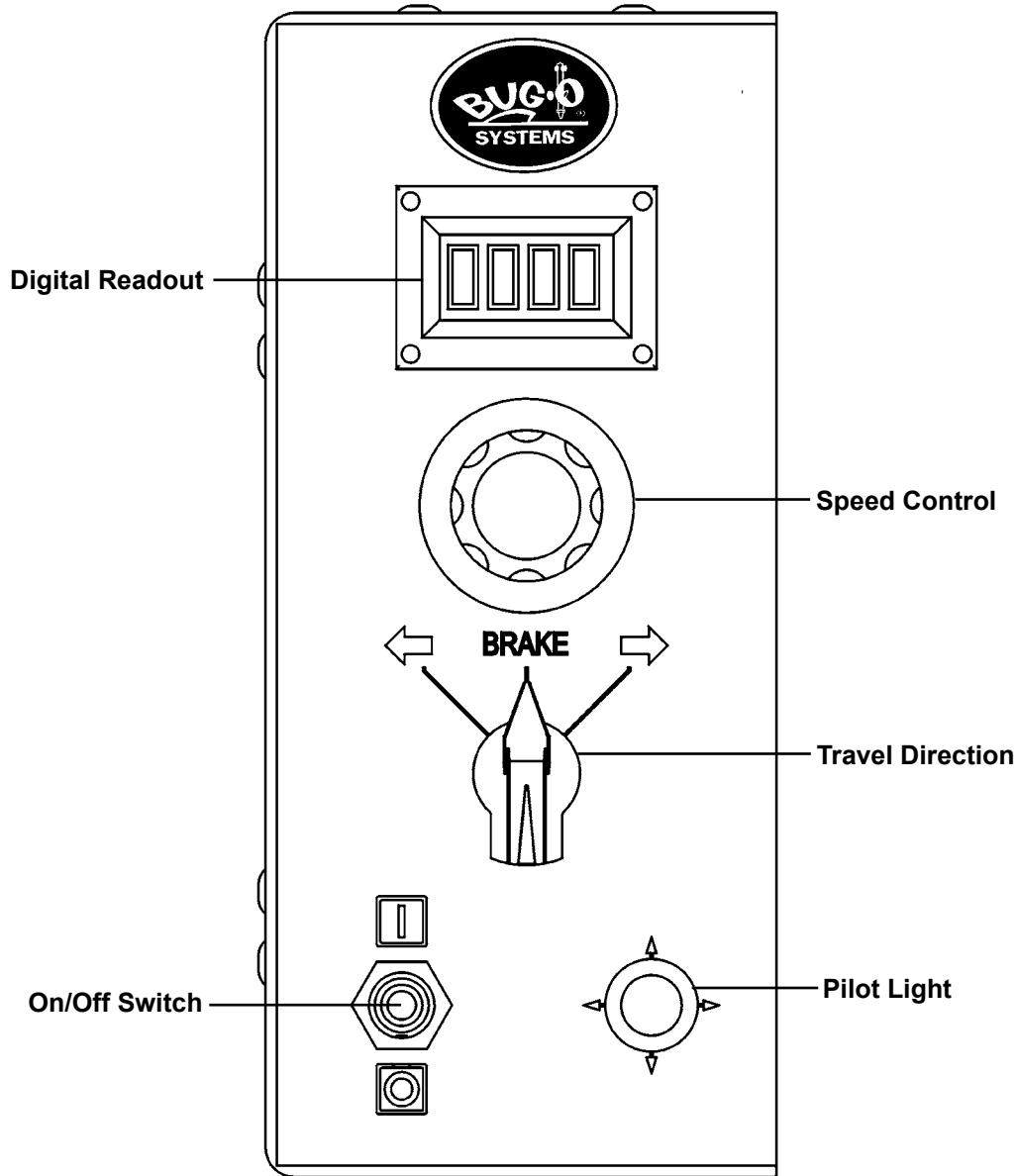

DIGITAL READOUT:

Displays reference number only.

SPEED CONTROL:

Controls the speed in which the machine travels. The depicted lines 0 to 100 should not be construed as inches per minute of travel. They should be considered as reference points only.

TRAVEL DIRECTION:

Controls the direction in which the machine will travel. Select forward for clockwise rotation, brake for stop, and reverse for counterclockwise rotation.

ON/OFF SWITCH:

The on/off switch enables/disables power to the rotation control box.

PILOT LIGHT:

The pilot light indicates whether the machine is on/off as dictated by the on/off switch.

TECHNICAL DATA:

Amperage:	0-500 amps
Input Voltage:	115 VAC
Voltage:	0-50 VAC
Wire Sizes:	.035 - 3/32" (.8 - 2.38 mm)
Rotation Speed:	.5-6.0 rpm
Cam Range:	5" (125 mm)
Welding Diameter:	1 - 12" (25 - 300 mm)
Shielding Gas:	Solenoid Control
Height:	39" (991 mm)
Net Weight:	189 lbs. (86 kg)
Shipping Weight:	400 lbs. (181 kg)

DIMENSIONS:

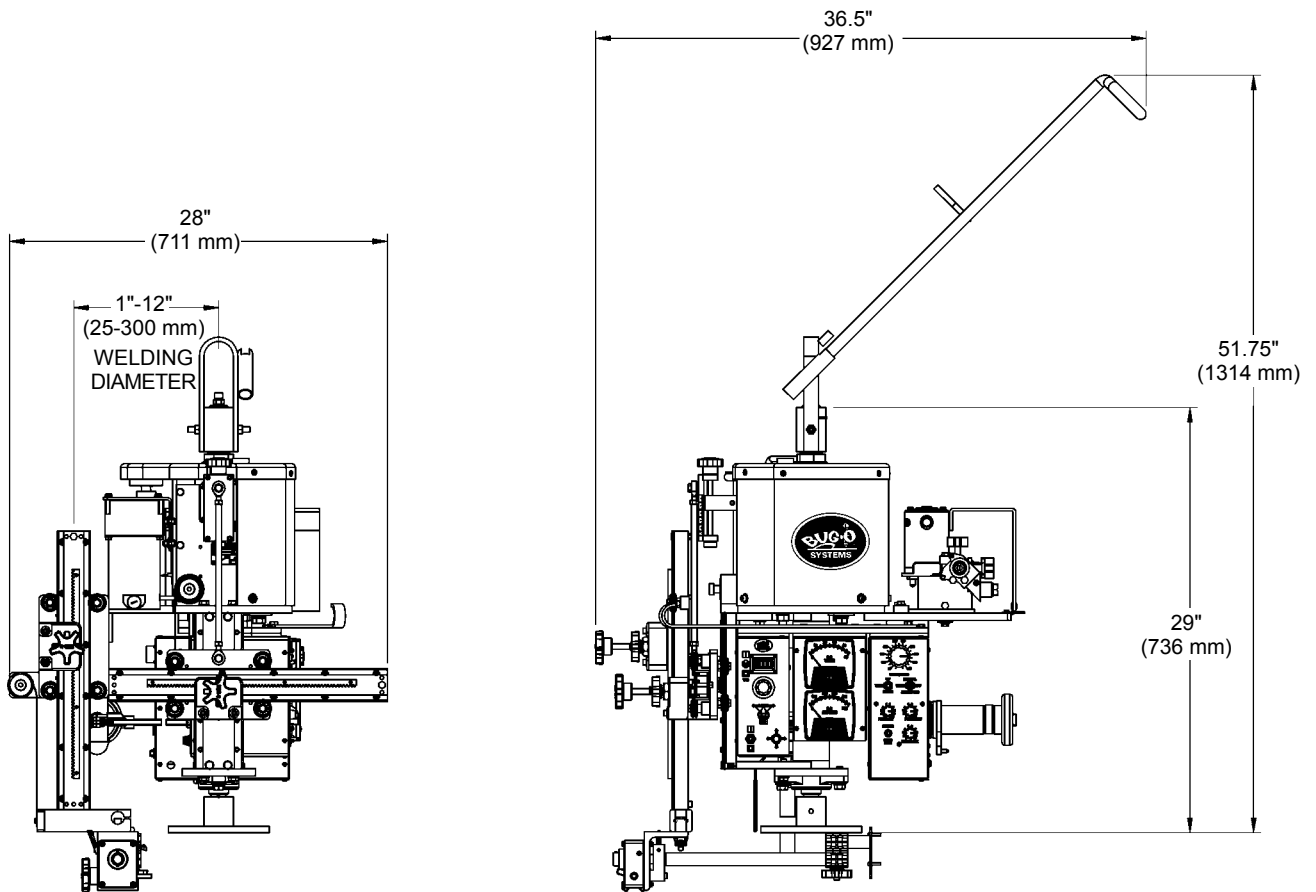

CW-5AX CIRCLE WELDER / EXPLODED VIEW

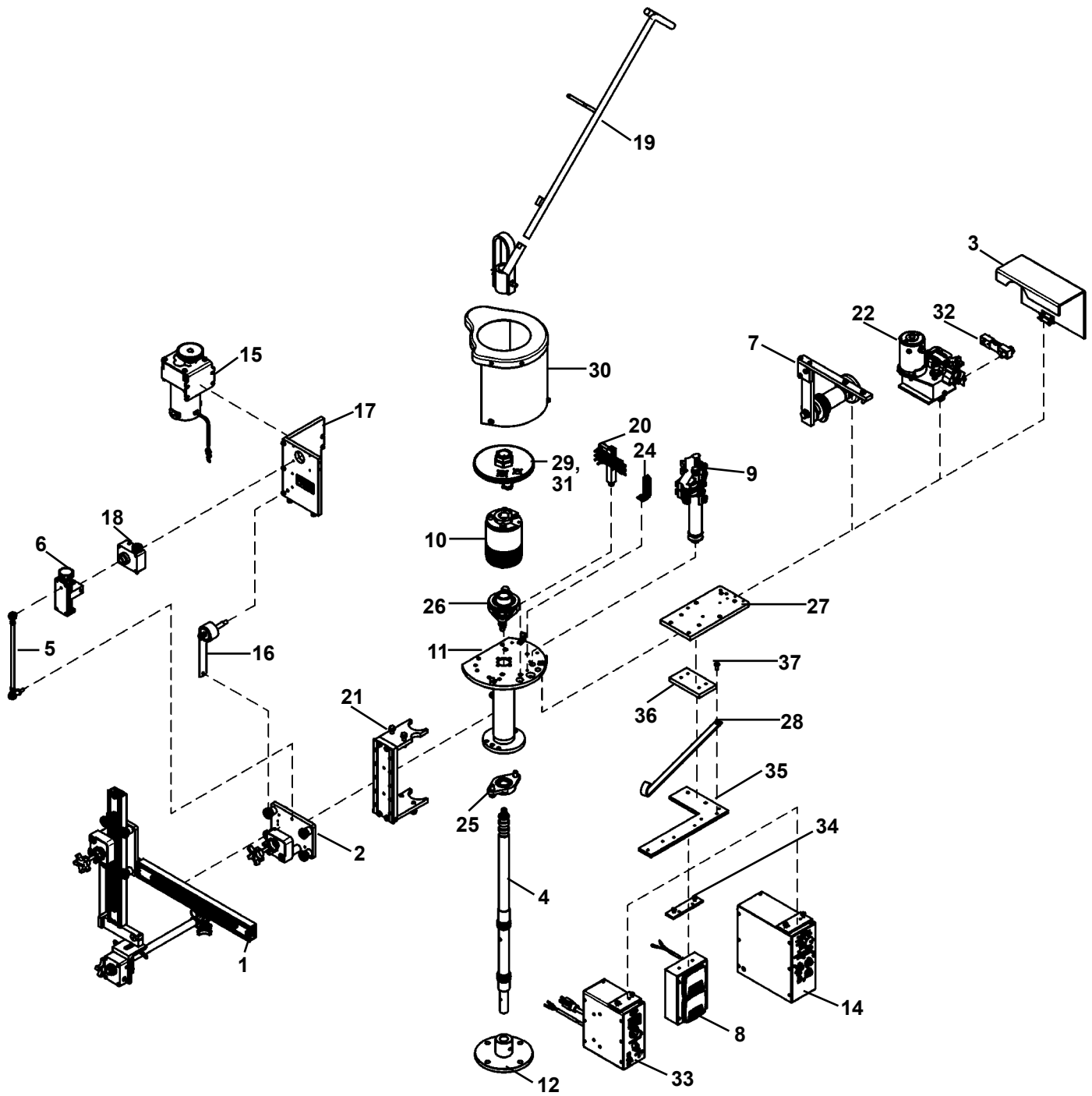

CW-5AX CIRCLE WELDER / PARTS LIST

<u>ITEM</u>	<u>QTY</u>	<u>PART NO.</u>	<u>DESCRIPTION</u>
1	1	CWO-1660	CW-5AX Racking System
2	1	CWO-1685	Small Horizontal Racker
3	1	CWO-2005	Wire Feed Guard
4	1	CWO-3001	CW-5 Shaft Assembly
5	1	CWO-3004	Cam Shaft & Spacer Assembly
6	1	CWO-3005	5" Cam Assembly
7	1	CWO-3008	Wire Reel Assembly
8	1	CWO-3027	Meter Kit Assembly
9	1	CWO-3063-2	Brush Holder & Support Assembly
10	1	CWE-3129	CW-5AX Collector
11	1	CWO-3199	CW-5 Housing Assembly
12	1	CWO-3303	Base Plate CW-5AX
13	1	CWO-3309	Lifting Lug Weldment
14	1	CWO-3332	GMA Wire Feed Control
15	1	CWO-3384	P.M. Motor Assembly
16	1	CWO-3399	Load Spring Assembly
17	1	CWO-3417	Motor & Transmission Plate Assembly
18	1	CWO-3418	Transmission 3.5:1 Assembly
19	1	CWO-3419	Cable Support Bar
20	1	CWE-1530	Small Brush Retainer Assembly
21	1	CWO-3466	Slide Bar Mounting Assembly
22	1	CWO-3468	LN-9 Wire Feeder Assembly
*23	1	CWO-3480	CW-5AX Flux Hopper Assembly
24	1	CWO-3955	Terminal Block Assembly
25	1	CWO-4050	1" Bearing w/Fasteners
26	1	CWO-4060	1-1/4" Bearing w/Fasteners
27	1	CWO-4088	Wire Feeder Mount Plate
28	1	CWO-4092	Cable Support
29	1	CWO-5075	1-1/4" Trantorque
30	1	CWO-5220	Guard Assembly
31	1	CWO-5740	7" Gear Aluminum CW-5AX
32	1	CWO-6008	Shunt Bar 500-50
33	1	CWO-6210	Rotation Control Box
34	1	CWO-6420	Meter Kit Mounting Assembly
35	1	CWO-6421	Control Mt. Bracket
36	1	CWO-6422	Control Mt. Spacer
37	1	FAS-0376	Hex Hd Cap Scr 5/16-18 X 5/8"

- NOTES:**
1. See CWO-1560-WD for wiring and cable information.
 2. CWO-3332 is shown with CWO-3332-K kit installed.
 3. CWO-6210 is shown with CWO-6110-K kit installed.

*(not shown) CW-5AX Flux Hopper Assembly included with Sub-Arc models only

CW-5 AX CIRCLE WELDER / WIRING DIAGRAM

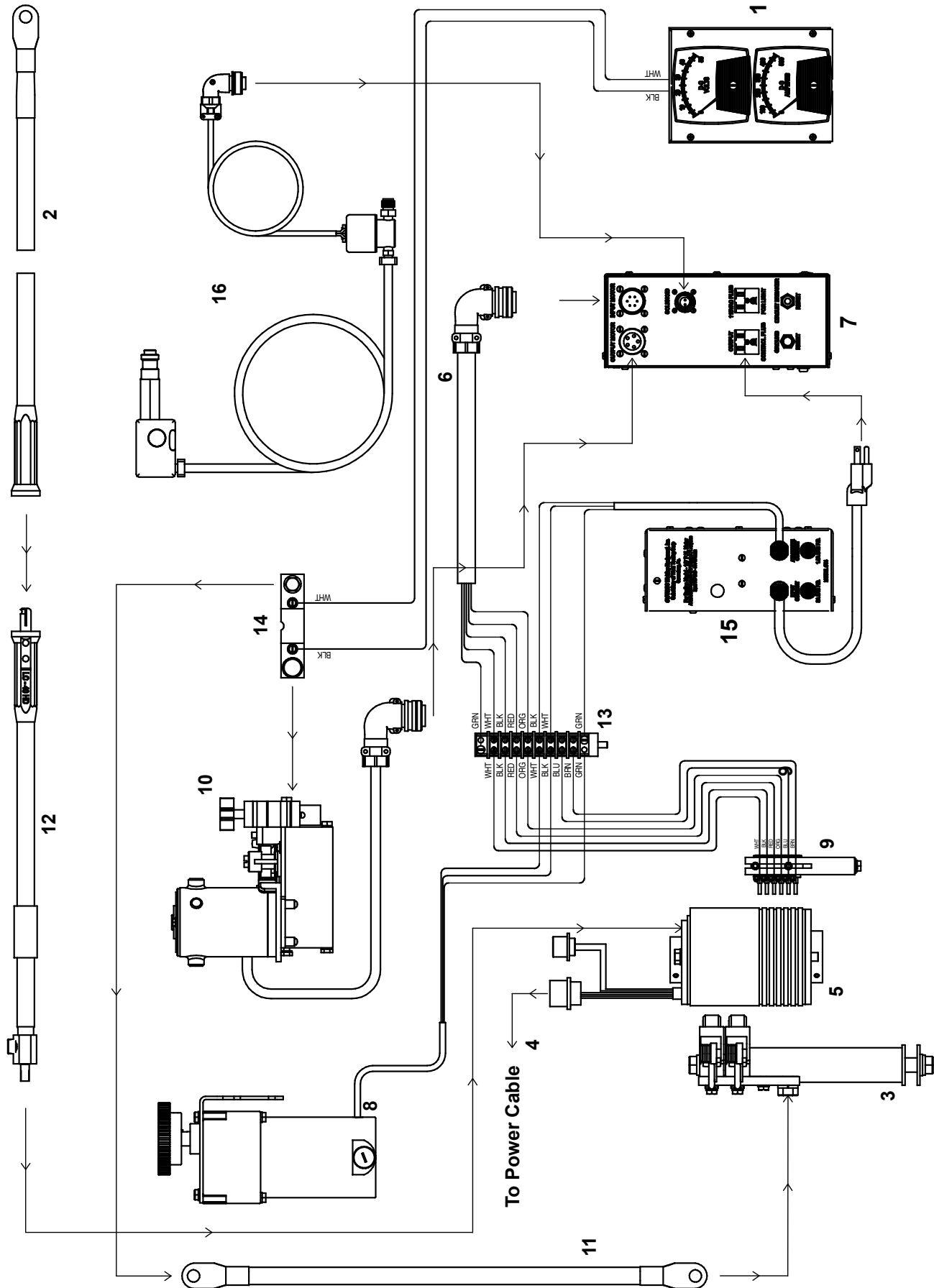

CW-5 AX CIRCLE WELDER / ELECTRICAL COMPONENT CHART

ELECTRICAL COMPONENT CHART		
ITEM	DESCRIPTION	PART NUMBER
1	Meter Kit Assy.	CWO-3027
2	Weld Cable 4/0 50'	CWO-3040
3	Brush Holder & Support Assy	CWO-3063-2
4	Power Cable	CWO-3139*
5	CW-5AX Collector	CWE-3129
6	GMA Pigtail	CWO-3331
7	GMA Wire Feeder Control	CWO-3332
8	P.M. Motor Assembly	CWO-3384
9	Small Brush Retainer	CWE-1530
10	LN-7 Wire Feeder Assy.	CWO-3468
11	Weld Cable 3/0	CWO-3478
12	Weld Cable 3/0 Inlet	CWO-3020-3/0
13	Terminal Block Assy.	CWO-3955
14	Shunt Bar 500 A 50 MV	CWO-6008
15	Rotation Control Box	CWO-6210
16	Solenoid Adaptor Kit	CWO-8057

*CWO-3139 for Universal Welders

CWO-3139-M for Miller Welders

CWO-1660 CW-5AX RACKING SYSTEM / EXPLODED VIEW / PARTS LIST

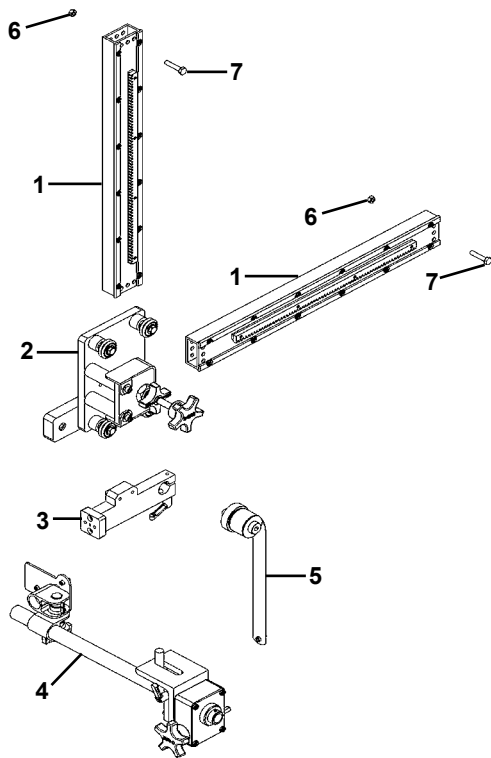

<u>ITEM</u>	<u>QTY</u>	<u>PART NO.</u>	<u>DESCRIPTION</u>
1	2	ABR-1070	V-Guide Ways 19"
2	1	CWO-1675	Vertical Racker
3	1	CWO-1695	Attachment Block
4	1	CWO-3023-1	Torch Angle Adjuster
5	1	CWO-3450	10.6# Load Spring Assy.
6	2	FAS-1351	Hex Nut 1/4-20
7	2	FAS-2351	Hex Hd Cap Scr 1/4-20 x 1-1/4"

CWO-1685 HORIZONTAL RACKER / EXPLODED VIEW / PARTS LIST

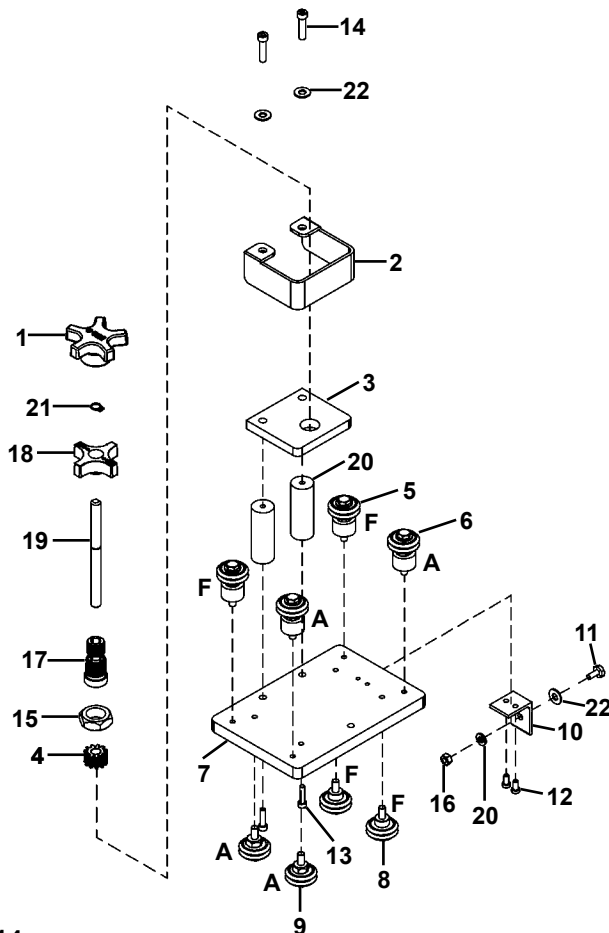

<u>ITEM</u>	<u>QTY</u>	<u>PART NO.</u>	<u>DESCRIPTION</u>
1	1	BUG-2032	Knob, Black
2	1	CWO-1671	Racker Shield
3	1	CWO-1678	Racker Plate
4	1	CWO-1679	Pinion 11T
5	2	CWO-1680	W2 Fixed Leg & Wheel Assy.
6	2	CWO-1681	W2 Adj. Leg & Wheel Assy.
7	1	CWO-1686	Mount Plate (Small Racker)
8	2	CWO-4020	Fixed Leg & Wheel Assy.
9	2	CWO-4021	Adj. Leg & Wheel Assy.
10	1	CWO-4112	Bracket
11	1	FAS-0355	Hex Hd Cap Scr 1/4-20 x 1/2"
12	2	FAS-0534	Soc Hd Cap Scr 10-24 x 3/8"
13	2	FAS-0557	Soc Hd Cap Scr 1/4-20 x 3/4"
14	2	FAS-0559	Soc Hd Cap Scr 1/4-20 x 1"
15	1	FAS-1307	Hex Jam Nut 3/4-16
16	1	FAS-1351	Hex Nut 1/4-20
17	1	MUG-1141	Bearing Collet
18	1	MUG-1142	Knob, Locking
19	1	MUG-1144	Shaft
20	2	MUG-1453	Stand-Off
21	1	MUG-1579	Retaining Ring
22	3	WAS-0240	1/4" SAE Washer
23	1	WAS-0243	1/4" Split Lock Washer

F = FIXED WHEEL PLACEMENT

A = ADJUSTABLE WHEEL PLACEMENT

CWO-3001 SHAFT ASSEMBLY / EXPLODED VIEW / PARTS LIST

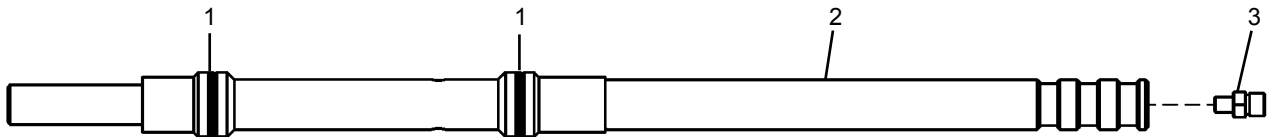

<u>ITEM</u>	<u>QTY</u>	<u>PART NO.</u>	<u>DESCRIPTION</u>
1	2	CWO-4003	O-Ring
2	1	CWO-5781	CWP-5 Shaft
3	1	BUG-9096	Outlet Bushing, Oxygen

CWO-3004 CAM SHAFT AND SPACER ASSEMBLY / EXPLODED VIEW / PARTS LIST

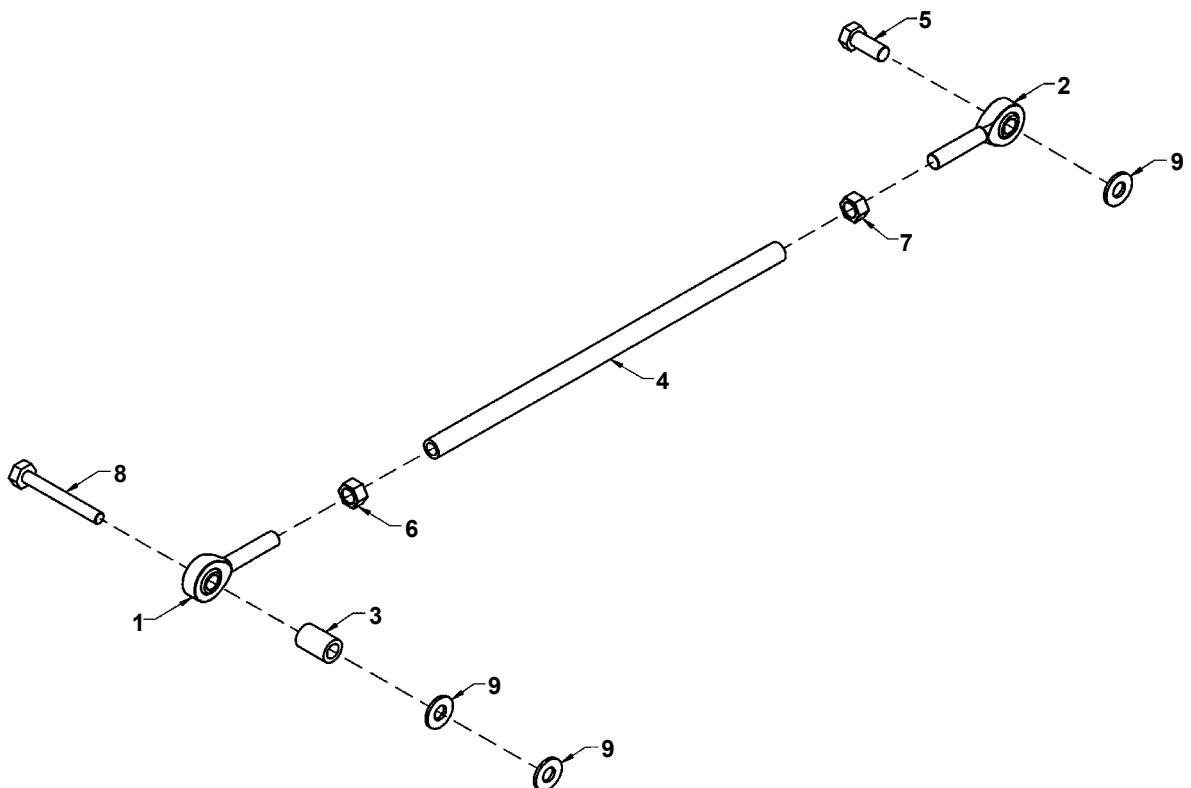

<u>ITEM</u>	<u>QTY</u>	<u>PART NO.</u>	<u>DESCRIPTION</u>
1	1	CWO-4073	Ball Joint Rod End 5/16-24 RH
2	1	CWO-5019	Ball Joint Rod End 5/16-24 LH
3	1	CWO-9078	Spacer 1/2" O.D. x 5/16 I.D. x 3/4"
4	1	CWO-9357	Cam Shaft Tube
5	1	FAS-0377	Hex Hd Cap Scr 5/16-18x3/4"
6	1	FAS-1380	Hex Nut 5/16-24
7	1	FAS-1381	Hex Nut 5/16-24 LH
8	1	FAS-2375	Hex Hd Cap Scr 5/16-18x2"
9	3	WAS-0250	5/16 SAE Washer

CWO-3005 5" CAM ASSEMBLY / EXPLODED VIEW / PARTS LIST

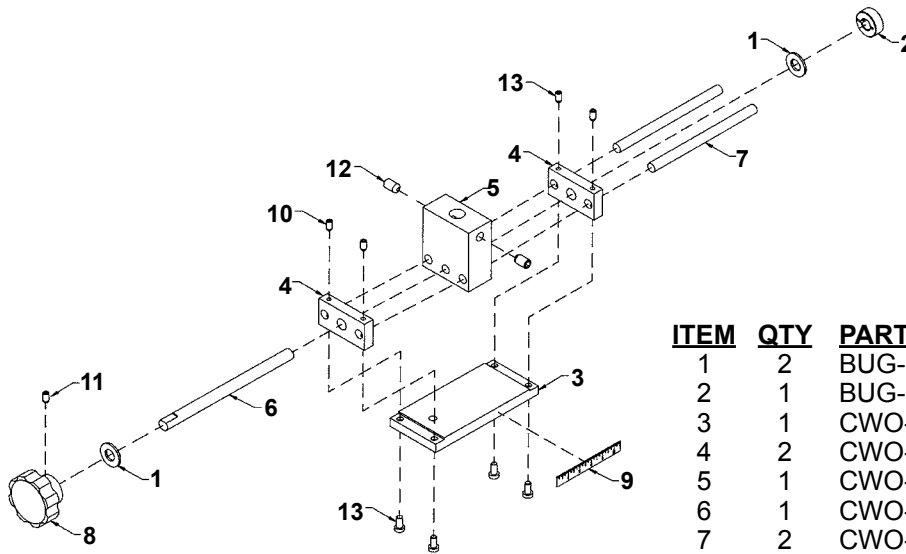

<u>ITEM</u>	<u>QTY</u>	<u>PART NO.</u>	<u>DESCRIPTION</u>
1	2	BUG-2098	Delrin Washer 3/8" I.D.
2	1	BUG-9012	Locking Collar
3	1	CWO-4026	Base Plate 4" Cam
4	2	CWO-4027	End Plate 4" Cam
5	1	CWO-4028	Center Block 4" Cam
6	1	CWO-4029	Screw 4" Cam
7	2	CWO-4031	Rod 4" Cam
8	1	CWO-4032	Knob
9	1	CWO-5199	Scale
10	4	FAS-0434	Set Scr 10-24x3/8"
11	1	FAS-0444	Set Scr 10-32x3/8"
12	2	FAS-0495	Set Scr 3/8-16x1/2"
13	4	FAS-0534	Soc Hd Cap 10-24x3/8"

CWO-3008 WIRE REEL MOUNT ASSEMBLY / EXPLODED VIEW / PARTS LIST

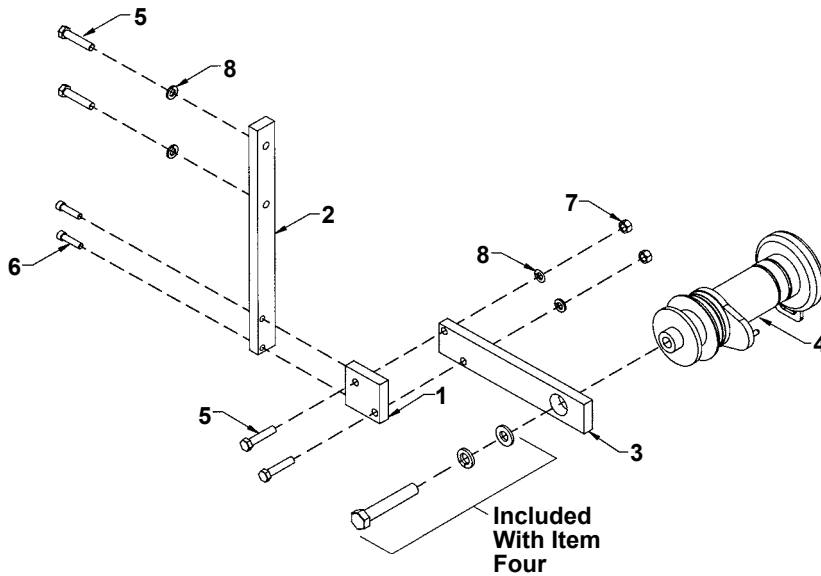

<u>ITEM</u>	<u>QTY</u>	<u>PART NO.</u>	<u>DESCRIPTION</u>
1	1	CWO-5977	Vertical Mount Plate
2	1	CWO-3743	Horizontal Mount Plate
3	1	CWO-4081	Wire Reel Mount Bar
4	1	WFU-1041	2" O.D. Spindle Kit
5	4	FAS-2373	Hex Hd Cap Scr 5/16-18x1-1/2"
6	2	FAS-0559	Soc Hd Cap Scr 1/4-20x1"
7	2	FAS-1370	Hex Nut 5/16-18
8	4	WAS-0251	5/16 Lock Washer

CWO-3027 METER KIT ASSEMBLY / EXPLODED VIEW / PARTS LIST

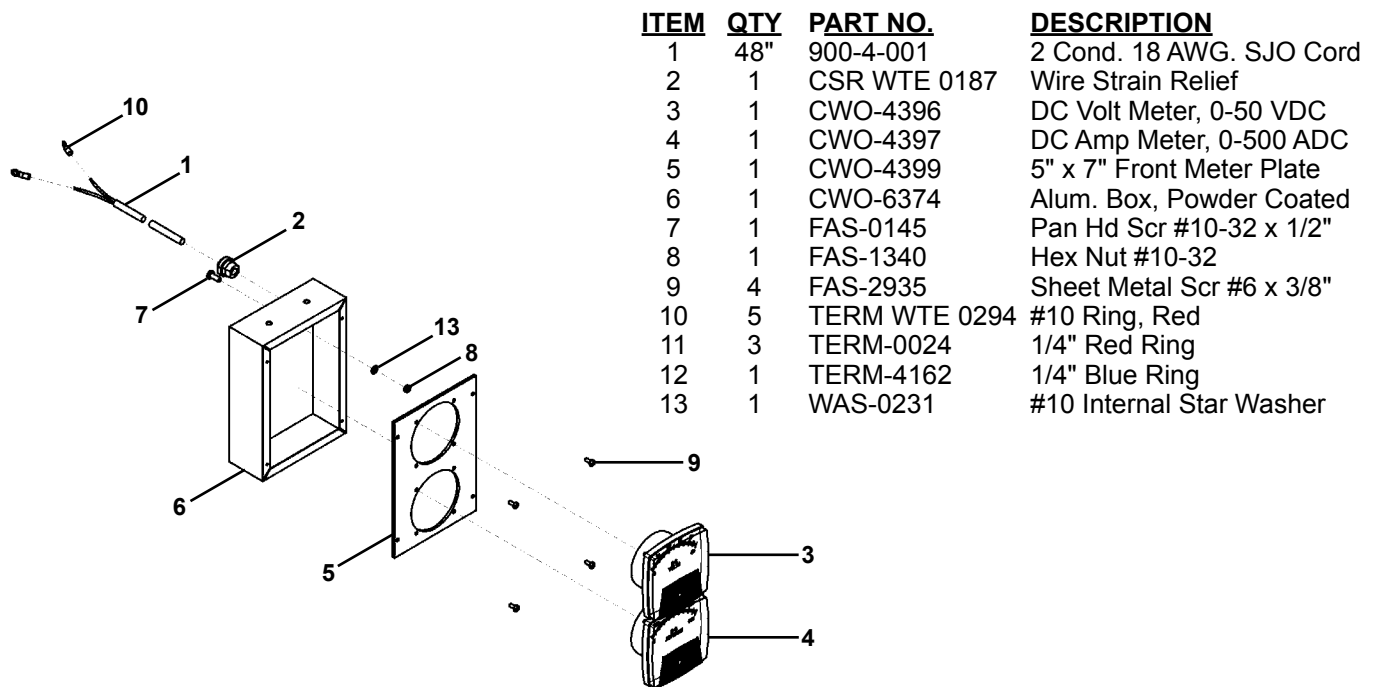

ITEM	QTY	PART NO.	DESCRIPTION
1	48"	900-4-001	2 Cond. 18 AWG. SJO Cord
2	1	CSR WTE 0187	Wire Strain Relief
3	1	CWO-4396	DC Volt Meter, 0-50 VDC
4	1	CWO-4397	DC Amp Meter, 0-500 ADC
5	1	CWO-4399	5" x 7" Front Meter Plate
6	1	CWO-6374	Alum. Box, Powder Coated
7	1	FAS-0145	Pan Hd Scr #10-32 x 1/2"
8	1	FAS-1340	Hex Nut #10-32
9	4	FAS-2935	Sheet Metal Scr #6 x 3/8"
10	5	TERM WTE 0294	#10 Ring, Red
11	3	TERM-0024	1/4" Red Ring
12	1	TERM-4162	1/4" Blue Ring
13	1	WAS-0231	#10 Internal Star Washer

CWO-3027 METER KIT ASSEMBLY / WIRING DIAGRAM

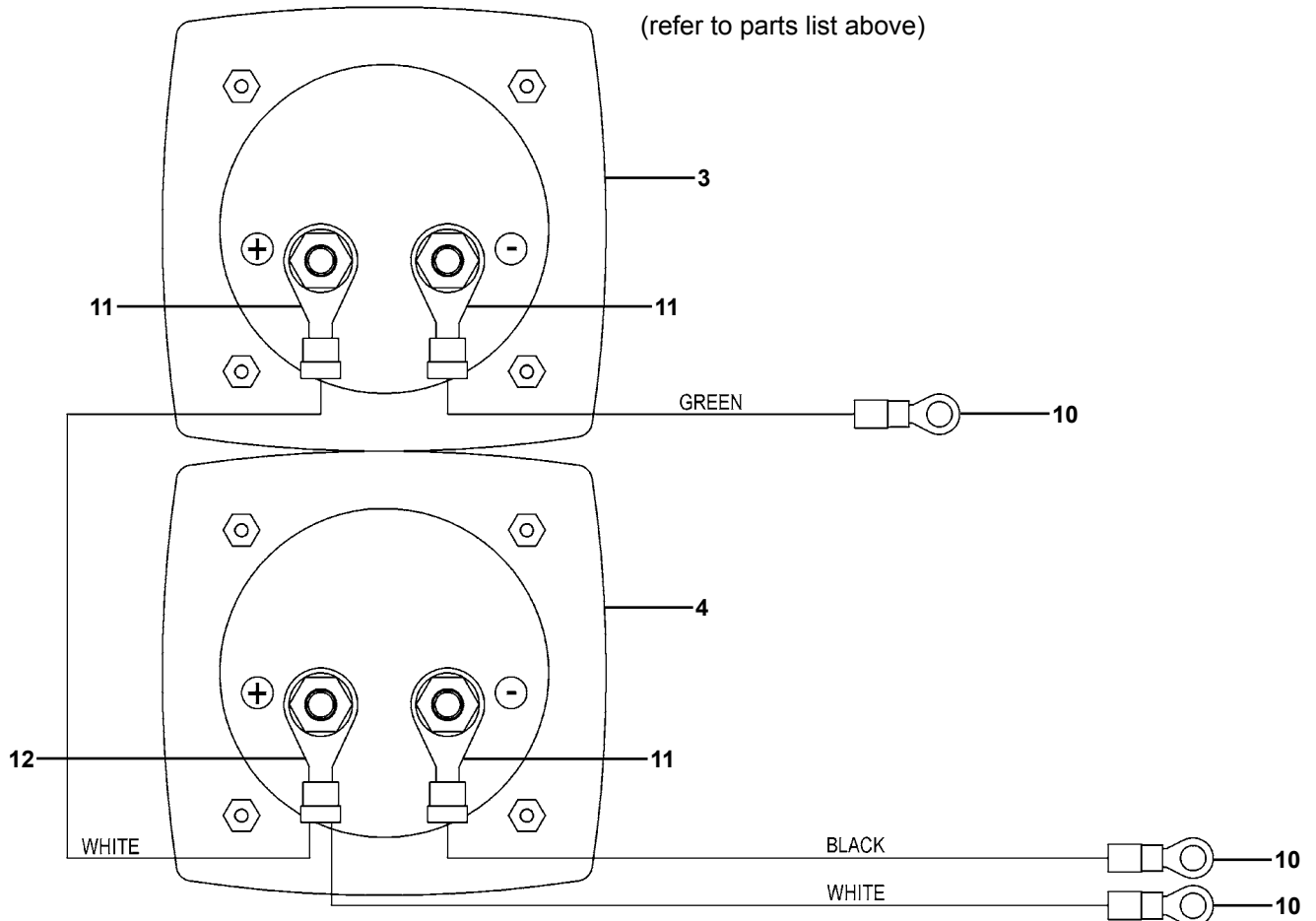

CWO-3063 LARGE BRUSH HOLDER AND SUPPORT / EXPLODED VIEW / PARTS LIST

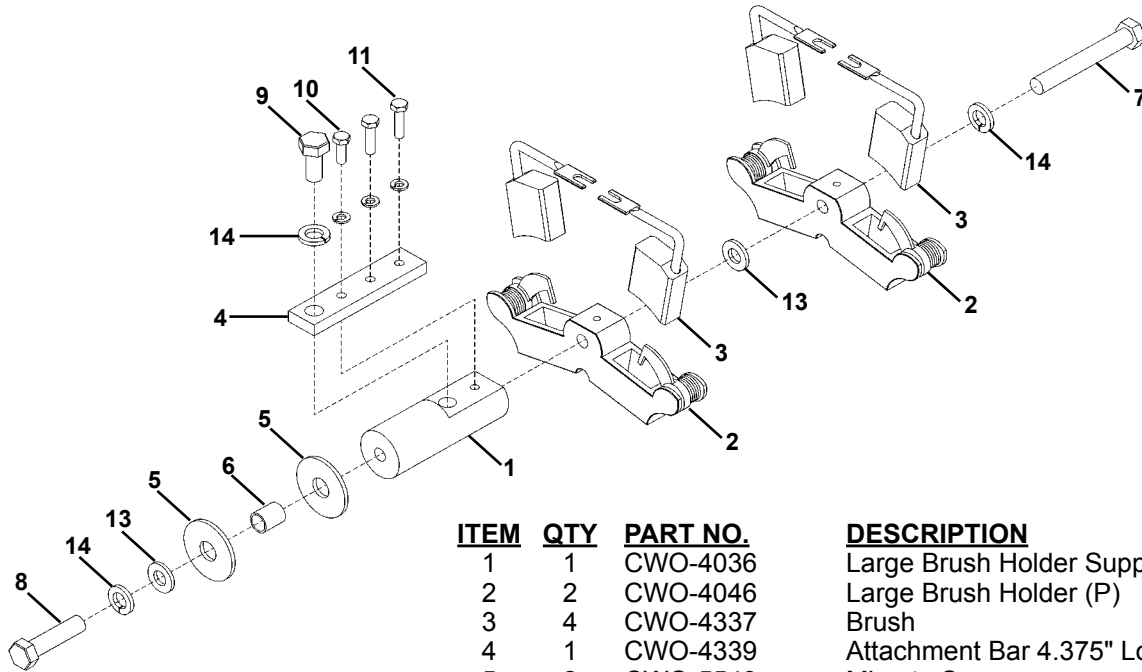

<u>ITEM</u>	<u>QTY</u>	<u>PART NO.</u>	<u>DESCRIPTION</u>
1	1	CWO-4036	Large Brush Holder Support (P)
2	2	CWO-4046	Large Brush Holder (P)
3	4	CWO-4337	Brush
4	1	CWO-4339	Attachment Bar 4.375" Long
5	2	CWO-5548	Micarta Spacer
6	1	CWO-5549	Micarta Bushing
7	1	FAS-0304	Hex Hd Cap Scr 1/2-13 x 3.5"
8	1	FAS-0305	Hex Hd Cap Scr 1/2-12 x 2"
9	1	FAS-0309	Hex Hd Cap Scr 1/2-13 x 1"
10	1	FAS-0357	Hex Hd Cap Scr 1/4-20 x 3/4"
11	2	FAS-0359	Hex Hd Cap Scr 1/4-20 x 1"
12	3	WAS-0243	1/4" Lock Washer
13	2	WAS-0280	1/2" Washer
14	3	WAS-0281	1/2" Lock Washer

CWO-3384 P.M. MOTOR ASSEMBLY / EXPLODED VIEW / PARTS LIST

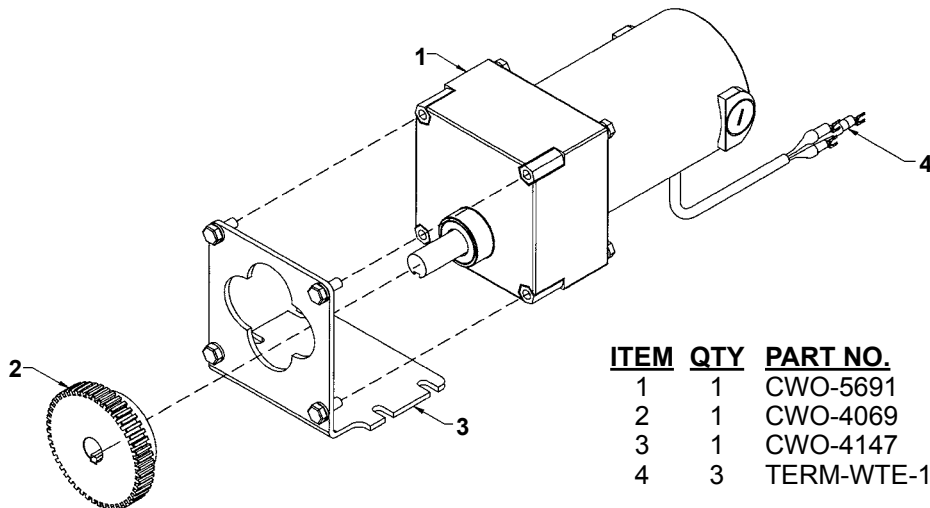

<u>ITEM</u>	<u>QTY</u>	<u>PART NO.</u>	<u>DESCRIPTION</u>
1	1	CWO-5691	P.M. Motor 1070
2	1	CWO-4069	Gear, P.M. Motor 1070
3	1	CWO-4147	P.M. Motor Bracket #970
4	3	TERM-WTE-1508	#8 Fork Blue 14RB-8FL T&B

CWO-3199 HOUSING ASSEMBLY / EXPLODED VIEW / PARTS LIST

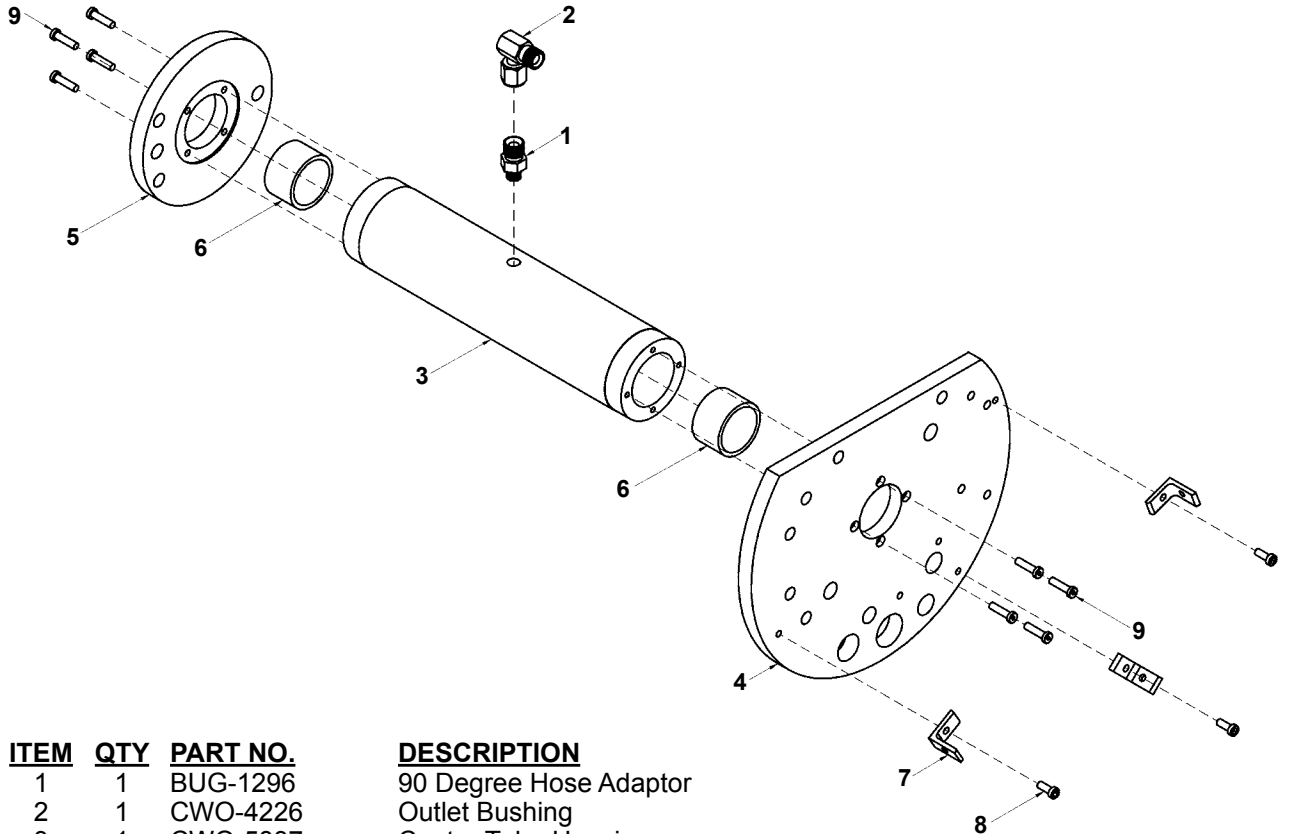

<u>ITEM</u>	<u>QTY</u>	<u>PART NO.</u>	<u>DESCRIPTION</u>
1	1	BUG-1296	90 Degree Hose Adaptor
2	1	CWO-4226	Outlet Bushing
3	1	CWO-5837	Center Tube Housing
4	1	CWO-5843	Top Housing Plate CW-5
5	1	CWO-5846	Lower Housing Plate CW-5
6	2	CWO-5975	Insert 1-5/8" O.D. x 1.376" I.D. x 1"
7	3	CWO-9339	Angle For Guard
8	3	FAS-0535	Soc Hd Cap Scr 10-24 x 1/2"
9	8	FAS-0548	Soc Hd Cap Scr 10-32 x 3/8"

CWO-3332 GMA WIRE FEEDER CONTROL / EXPLODED VIEW / PARTS LIST

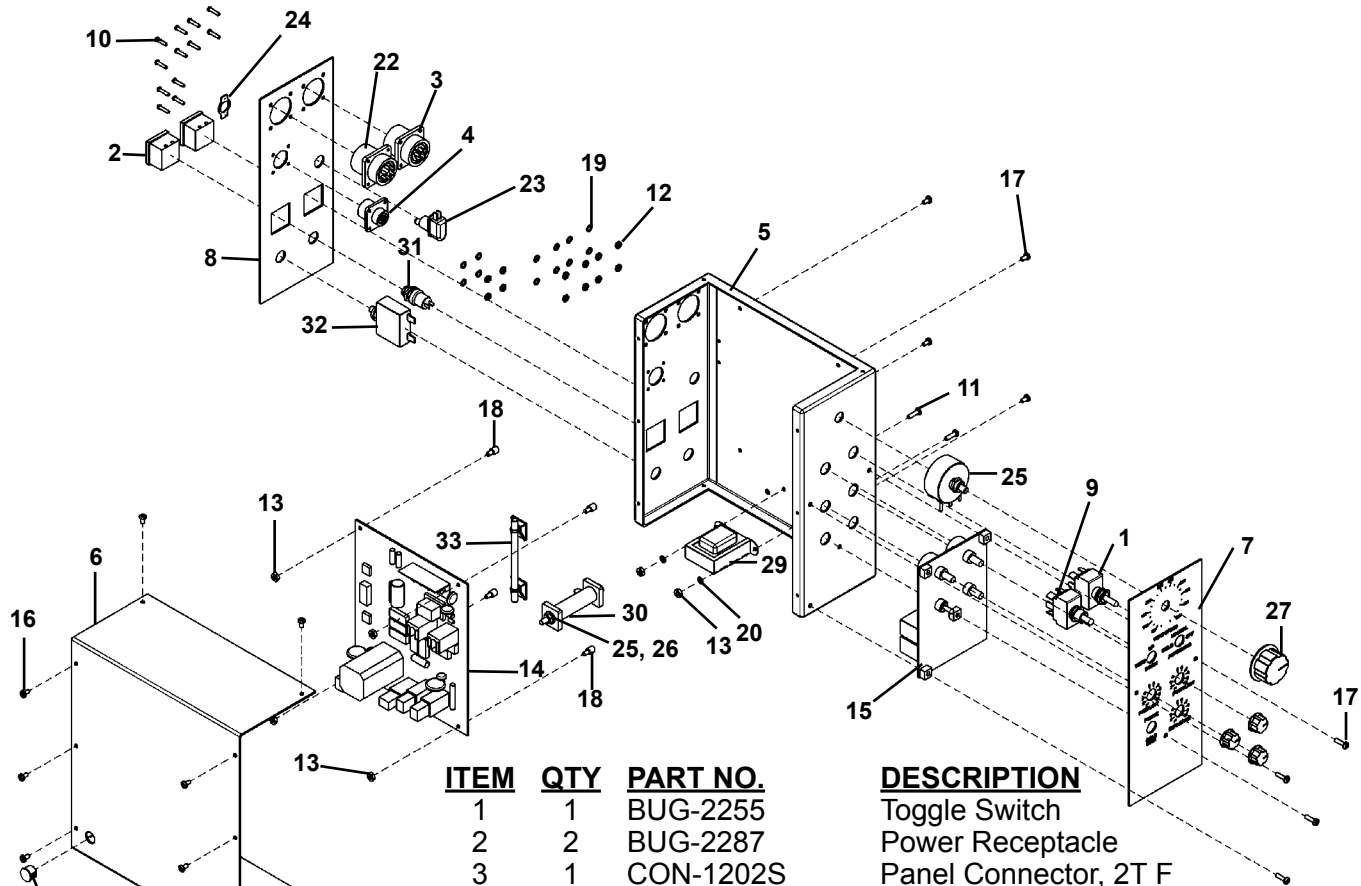

<u>ITEM</u>	<u>QTY</u>	<u>PART NO.</u>	<u>DESCRIPTION</u>
1	1	BUG-2255	Toggle Switch
2	2	BUG-2287	Power Receptacle
3	1	CON-1202S	Panel Connector, 2T F
4	1	CWO-6759	Panel Connector, 6T M
5	1	CWO-5461	Wire Feed Control Case
6	1	CWO-5462	Wire Feed Control Cover
7	1	CWO-5533A	Wire Feed Front Panel
8	1	CWO-5533B	Wire Feed Rear Panel
9	1	CWO-6335	Toggle Switch
10	12	FAS-0205	Rnd Hd Scr 4-40 X 1/2"
11	2	FAS-0215	Rnd Hd Scr #6-32 X 1/2"
12	12	FAS-1305	Hex Nut 4-40
13	6	FAS-1310	Hex Nut #6-32
14	1	LN7 WTE 1351	Motor Control Board
15	1	PCB-1350	Timing Control Board
16	10	SCW WTE 1435	Pan Hd Scr #6-32 X 1/4"
17	4	SCW WTE 0481	Pan Hd Scr #6-32 X 1/2"
18	4	STOF-2009	Stand Off #6-32
19	12	WAS-0201	#4 Internal Star Lock Washer
20	2	WAS-0211	#6 Internal Star Lock Washer
21	1	MUG-1589	Hole Plug .522"
22	1	MS-2A18-11S	Panel Connector, 5T M
23	1	ABP-1069	Toggle Switch
24	1	BUG-9884	On-Off Switch Plate
25	1	LDC-1113	Plain Washer for LN-7
26	2	LDC-1114	Hex Nut 10-24 for LN-7
27	1	LDC-1104	Knob for LN-7
28	1	LDC-1103	Potentiometer for LN-7
29	1	LDC-1107	Transformer & Lead Assembly
30	1	LDC-1109	Resistor for LN-7
31	1	LDC-1108	Switch for LN-7
32	1	LN7 WTE 1352	Circuit Breaker 250V 2.5A
33	1	LDC-1101	Reed Switch Assy for LN-7

CWO-6210 ROTATION CONTROL BOX / EXPLODED VIEW / PARTS LIST

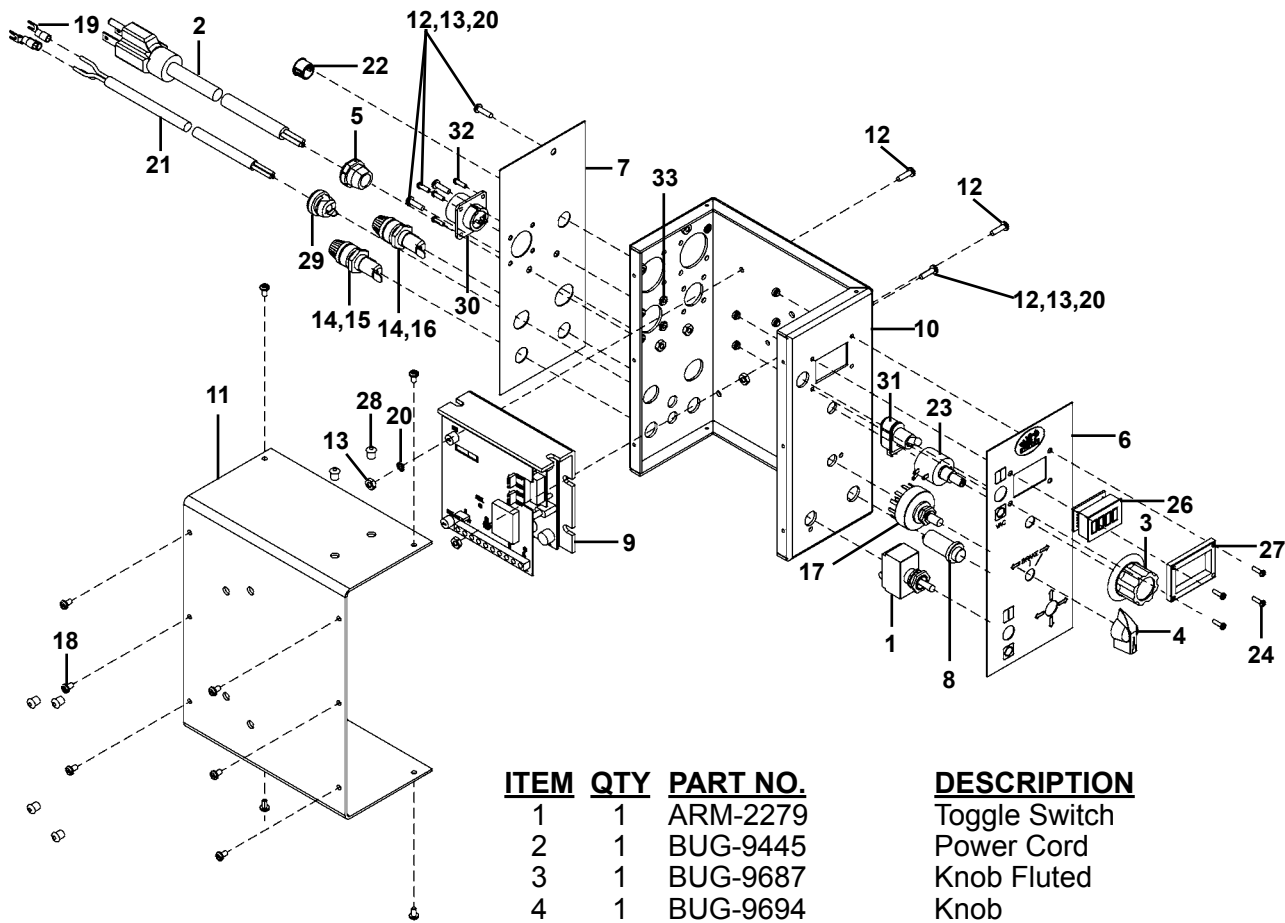

<u>ITEM</u>	<u>QTY</u>	<u>PART NO.</u>	<u>DESCRIPTION</u>
1	1	ARM-2279	Toggle Switch
2	1	BUG-9445	Power Cord
3	1	BUG-9687	Knob Fluted
4	1	BUG-9694	Knob
5	2	CSR-1597	Cord Strain Relief
6	1	CWO-6216	Rotation Box Front Panel
7	1	CWO-5547B	Rotation Box Rear Panel
8	1	CWO-6206	Indicator Light
9	1	CWO-6527	0-90V Spd Ctrl w. Isolator
10	1	CWO-6839	Rotation Control Case
11	1	CWO-6802	Rotation Box Cover
12	6	FAS-0115	#6-32 x 1/2" Pan Head Zinc
13	6	FAS-1310	Hex Nut 6-32
14	2	FHO-0188	Fuse Holder
15	1	MPD-1026	Fuse 2 Amp
16	1	FUS-0257	Fuse 3 Amp
17	1	MUG-1258-1	Rotary Switch Assembly
18	10	SCW-WTE-0264	#6-32 x 1/4" Sht Mt Scr
19	3	TERM-WTE-0197	#6 Red Fork
20	6	WAS-0211	#6 Internal Star Washer
21	42"	WRE-WTE-0501	18/3 SJO 300V Cord
22	1	MUG-1589	Hole Plug .500"
23	1	BUG-1562	Multi-turn Potentiometer
24	4	FAS-0401	#4-40 X 3/8" Pan Hd
25	4	SCF-1001	#4-40 Self Clinching Nut
26	1	BUG-1764	Meter Display Board
27	1	MDS-1011	Display Bezel
28	6	BUG-3331	Hole Plug 1/4"
29	1	CSR-1598	Cord Strain Relief Bushing
30	1	BUG-9486	Panel Connector, 2T, M
31	1	ABP-1069	Toggle Switch, SPST
32	4	FAS-0204	Rmd Slit Jd Scr 4-40 x 3/8" Zinc
33	4	FAS-1305	Hex Nut 4-40

CWO-6210 ROTATION CONTROL BOX / WIRING DIAGRAM

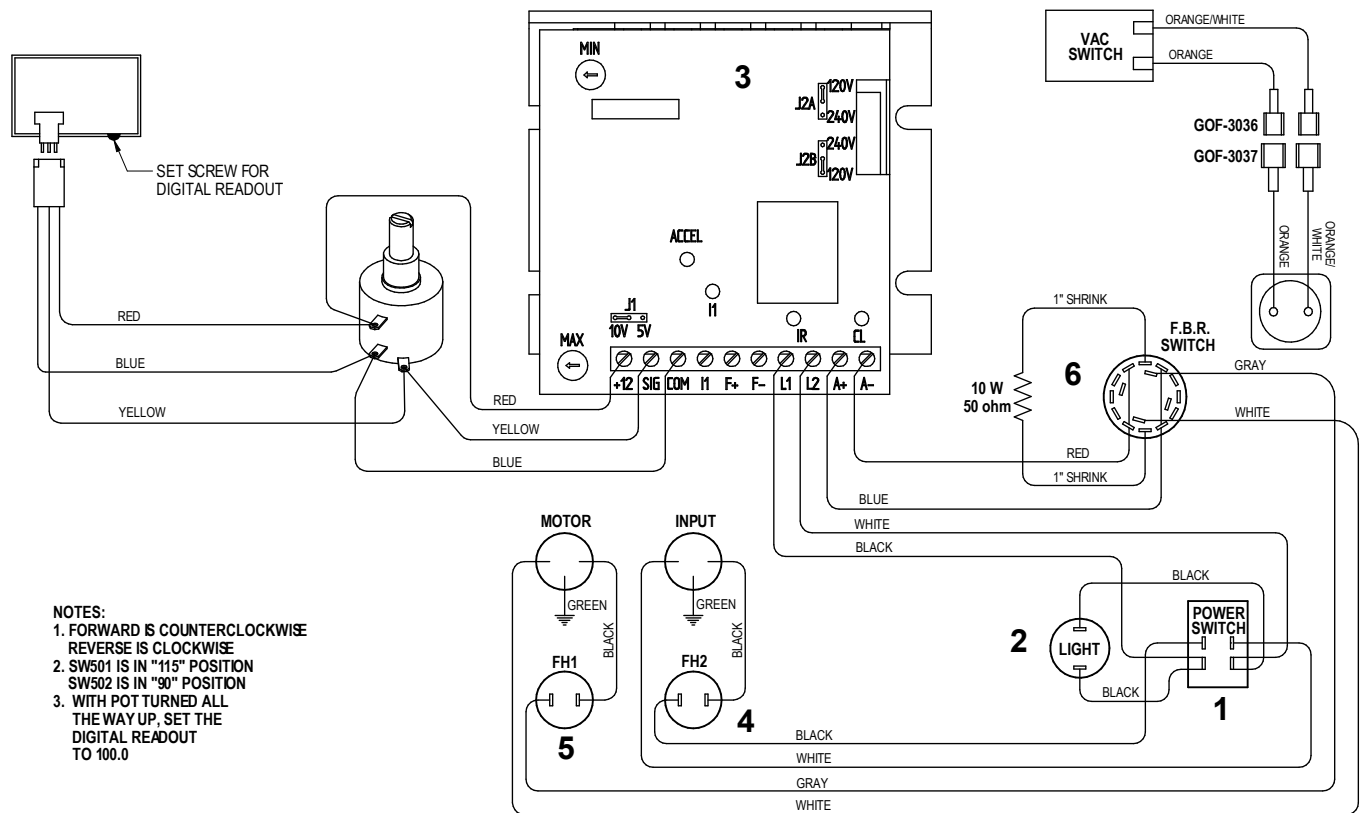

--- = INDICATES ITEMS THAT ARE SUPPLIED TOGETHER

ELECTRICAL COMPONENT CHART

ITEM	DESCRIPTION	PART NUMBER
1	Toggle Switch	ARM-2279
2	Red Neon Lamp	CWO-6206
3	Speed Control Board w/Resistor	CWO-6527
4	Fuse 1.5 amp	FUS-0190
5	Fuse 3 amp	FUS-0257
6	Rotary Switch	MUG-1258-1

CW-5AX GUN ASSEMBLIES (MIG/FLUX-CORED)

CWO-1560-A #5 .035 GUN ASSEMBLY MIG/FLUX	.035" (.9MM) WIRE SIZE	
CWO-8027	15H-35 CONTACT TIP	10
CWO-8034	25CT-75 NOZZLE	1
CWO-8035	35CT NOZZLE INSULATOR	1
CWO-8036	55 SW GAS DIFFUSER	1
CWO-8039	45-3545-15 CABLE LINER	1
CWO-8524	50394 500 AMP GUN	1
CWO-1560-B #5 .045 GUN ASSEMBLY MIG/FLUX	.045" (1.1/1.2MM) WIRE SIZE	
CWO-8028	15H-45 CONTACT TIP	10
CWO-8034	25CT-75 NOZZLE	1
CWO-8035	35CT NOZZLE INSULATOR	1
CWO-8036	55 SW GAS DIFFUSER	1
CWO-8039	45-3545-15 CABLE LINER	1
CWO-8524	50394 500 AMP GUN	1
CWO-1560-C #5 1/16 GUN ASSEMBLY MIG/FLUX	1/16" (1.6MM) WIRE SIZE	
CWO-8029	15H-116 CONTACT TIP	10
CWO-8034	25CT-75 NOZZLE	1
CWO-8035	35CT NOZZLE INSULATOR	1
CWO-8037	55 GAS DIFFUSER	1
CWO-8041	45-116-15 CABLE LINER	1
CWO-8524	50394 500 AMP GUN	1
CWO-1560-D #5 5/64 GUN ASSEMBLY MIG/FLUX	5/64" (2MM) WIRE SIZE	
CWO-8031	15H-564 CONTACT TIP	10
CWO-8034	25CT-75 NOZZLE	1
CWO-8035	35CT NOZZLE INSULATOR	1
CWO-8038	55 GAS DIFFUSER	1
CWO-8085	45-564-15 CABLE LINER	1
CWO-8524	50394 500 AMP GUN	1
CWO-1560-E #5 3/32 GUN ASSEMBLY MIG/FLUX	3/32" (2.4MM) WIRE SIZE	
CWO-8032	15H-332 CONTACT TIP	10
CWO-8034	25CT-75-NOZZLE	1
CWO-8035	35CT NOZZLE INSULATOR	1
CWO-8042	45H-332-15 CABLE LINER	1
CWO-8038	55H-GAS DIFFUSER	1
CWO-8524	50394 500 AMP GUN	1
CWO-1560-G #5 .052 GUN ASSEMBLY MIG/FLUX	.052" (1.3/1.4MM) WIRE SIZE	
CWO-8024	15H-52 CONTACT TIP	10
CWO-8034	25CT-75 NOZZLE	1
CWO-8035	35CT NOZZLE INSULATOR	1
CWO-8036	55 SW GAS DIFFUSER	1
CWO-8041	45-116-15 CABLE LINER	1
CWO-8524	50394 500 AMP GUN	1

CW-5AX GUN ASSEMBLIES (SUB ARC)

CWO-1700-A	#5 .035 GUN ASSEMBLY SUB ARC	.035" (.8MM) WIRE SIZE	
	CWO-8027	15H-35 CONTACT TIP	10
	CWO-8036	55 SW GAS DIFFUSER	1
	CWO-8039	45-3545-15 CABLE LINER	1
	CWO-8054	25-SA NOZZLE FLUX CONE	1
	CWO-8524	50394 500 AMP GUN	1
CWO-1700-B	#5 .045 GUN ASSEMBLY SUB ARC	.045" (1.14MM) WIRE SIZE	
	CWO-8028	15H-45 CONTACT TIP	10
	CWO-8036	55 SW GAS DIFFUSER	1
	CWO-8039	45-3545-15 CABLE LINER	1
	CWO-8054	25-SA NOZZLE FLUX CONE	1
	CWO-8524	50394 500 AMP GUN	1
CWO-1700-C	#5 1/16 GUN ASSEMBLY SUB ARC	1/16" (1.6MM) WIRE SIZE	
	CWO-8029	15H-116 CONTACT TIP	10
	CWO-8037	55 GAS DIFFUSER	1
	CWO-8041	45-116-15 CABLE LINER	1
	CWO-8054	25-SA NOZZLE FLUX CONE	1
	CWO-8524	50394 500 AMP GUN	1
CWO-1700-D	#5 5/64 GUN ASSEMBLY SUB ARC	5/64" (2MM) WIRE SIZE	
	CWO-8031	15H-564 CONTACT TIP	10
	CWO-8038	55 GAS DIFFUSER	1
	CWO-8042	45-116-15 CABLE LINER	1
	CWO-8054	25-SA NOZZLE FLUX CONE	1
	CWO-8524	50394 500 AMP GUN	1
CWO-1700-E	#5 3/32 GUN ASSEMBLY SUB ARC	3/32" (2.4MM) WIRE SIZE	
	CWO-8032	15H-332 CONTACT TIP	10
	CWO-8038	55H-GASS DIFFUSER	1
	CWO-8042	45-332-15 LINER	1
	CWO-8054	25-SA NOZZLE FLUX CONE	1
	CWO-8524	50394 500 AMP GUN	1
CWO-1700-G	#5 .052 GUN ASSEMBLY SUB ARC	.052" (1.3/1.4MM) WIRE SIZE	
	CWO-8024	15H-52 CONTACT TIP	10
	CWO-8036	55 SW GAS DIFFUSER	1
	CWO-8041	45-116-15 CABLE LINER	1
	CWO-8054	25-SA NOZZLE FLUX CONE	1
	CWO-8524	50394 500 AMP GUN	1

#5 GUN AND CABLE ASSEMBLY / EXPLODED VIEW / PARTS LIST

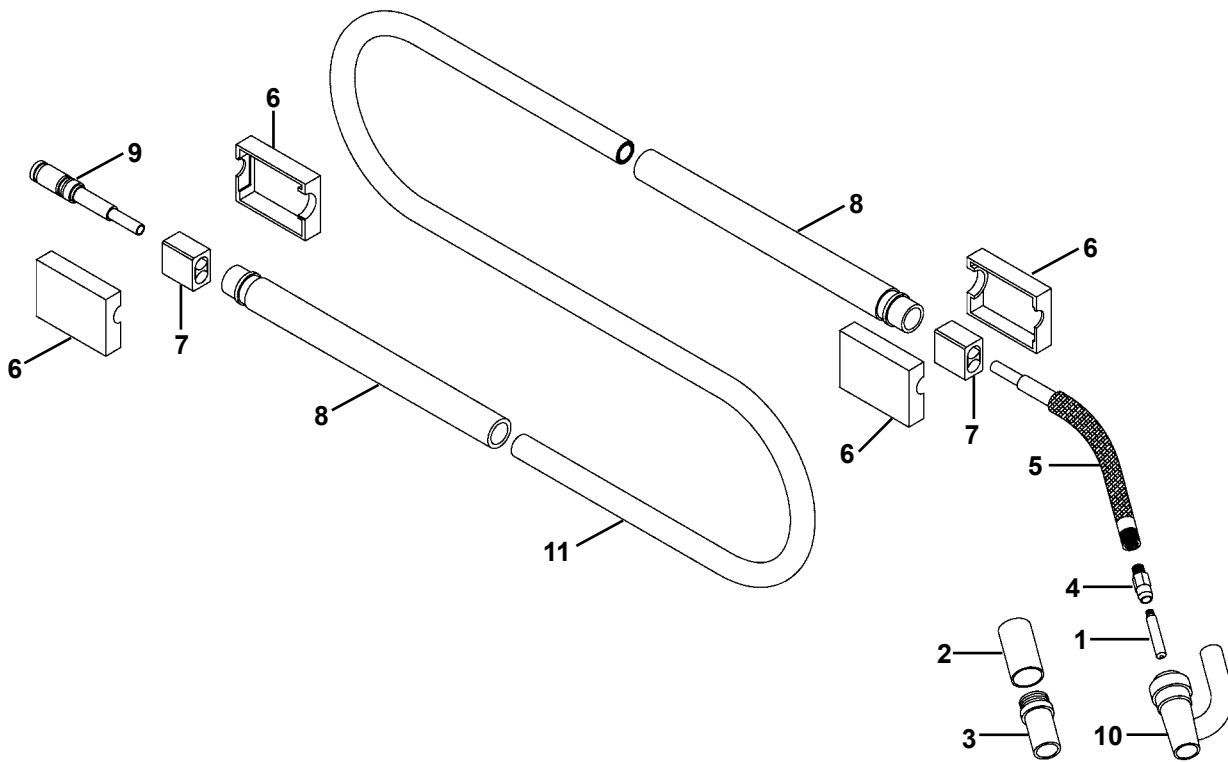

PARTS LIST				WIRE SIZE					
ITEM	QTY	PART #	DESCRIPTION	.035	.045	.052	1/16	5/64	3/32
1	1	CWO-8024	15H-52 Contact tip			X			
1	1	CWO-8027	15H-35 Contact Tip	X					
1	1	CWO-8028	15H-45 Contact Tip		X				
1	1	CWO-8029	15H-116 Contact Tip				X		
1	1	CWO-8031	15H-564 Contact Tip					X	
1	1	CWO-8032	15H-332 Contact Tip						X
2	1	CWO-8034	25CT-75 Nozzle Insulator	X	X	X	X	X	X
3	1	CWO-8035	35CT Nozzle Insulator	X	X	X	X	X	X
4	1	CWO-8036	55SW Gas Diffuser	X	X	X			
4	1	CWO-8037	55 Gas Diffuser				X		
4	1	CWO-8038	55H Gas Diffuser					X	X
5	1	CWO-8045	65-60 Conductor Tube	X	X	X	X	X	X
6	2	CWO-8017	185 Case w/Binder Screws	X	X	X	X	X	X
7	2	CWO-8018	104 Cable Connector Block	X	X	X	X	X	X
8	1	CWO-8052	Cable Hose Support	X	X	X	X	X	X
9	1	CWO-8053	175 Connector Plug w/O-Rings	X	X	X	X	X	X
10	1	CWO-8054	25-SA Nozzle Flux Cone	X	X	X	X	X	X
11	1	CWO-8524	50394 500 AMP Cable	X	X	X	X	X	X
*	1	CWO-8039	45-4535-15 Cable Liner	X	X				
*	1	CWO-8041	45-116-15 Cable Liner			X	X		
*	1	CWO-8042	45-332-15 Cable Liner						X
*	1	CWO-8085	45-564-15 Cable Liner					X	

* ITEMS NOT SHOWN

CWO-3418 TRANSMISSION 3.5:1 ASSEMBLY / EXPLODED VIEW / PARTS LIST

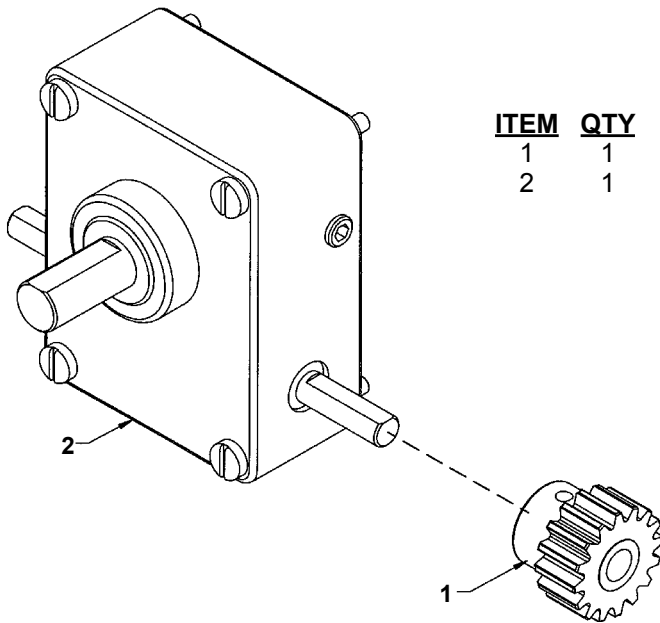

ITEM	QTY	PART NO.	DESCRIPTION
1	1	CWO-3276	Pinion Gear Assembly
2	1	CWO-4068	Transmission SW 3.5:1

CWE-1530 SMALL BRUSH HOLDER ASSEMBLY / EXPLODED VIEW / PARTS LIST

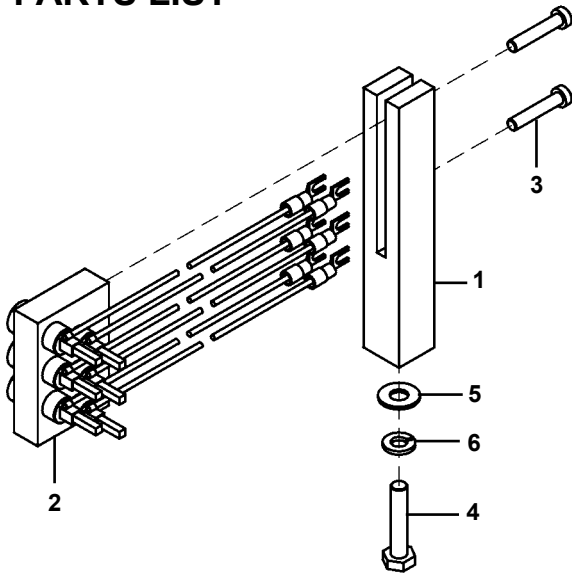

ITEM	QTY	PART NO.	DESCRIPTION
1	1	CWE-1531	Retainer Support Small
2	1	CWE-1532	6 Pos Small Ret. Block Assy.
3	2	FAS-2351	Soc Hd Cap Scr 10-24x1"
4	1	FAS-0539	Hex Hd Cap Scr 1/4-20x1 1/4"
5	1	WAS-0240	1/4" SAE Flat
6	1	WAS-0243	1/4" Split Lock Washer

CWO-3461 SMALL RETAINER BLOCK ASSEMBLY / DETAIL VIEW

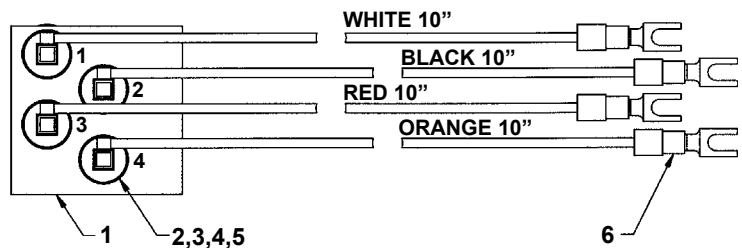

ITEM	QTY	PART NO.	DESCRIPTION
1	1	CWO-5626	Small Brush Retainer Blk
2	4	CWO-5831	Brush 1/8" x 1/8" x 7/8"
3	4	CWO-5874	Brush Holder
4	4	CWO-5875	Cap
5	4	CWO-5876	Clip
6	4	TERM WTE 0602	#6 Fork Blue

CWO-3480 CW-5AX FLUX HOPPER ASSEMBLY / EXPLODED VIEW / PARTS LIST

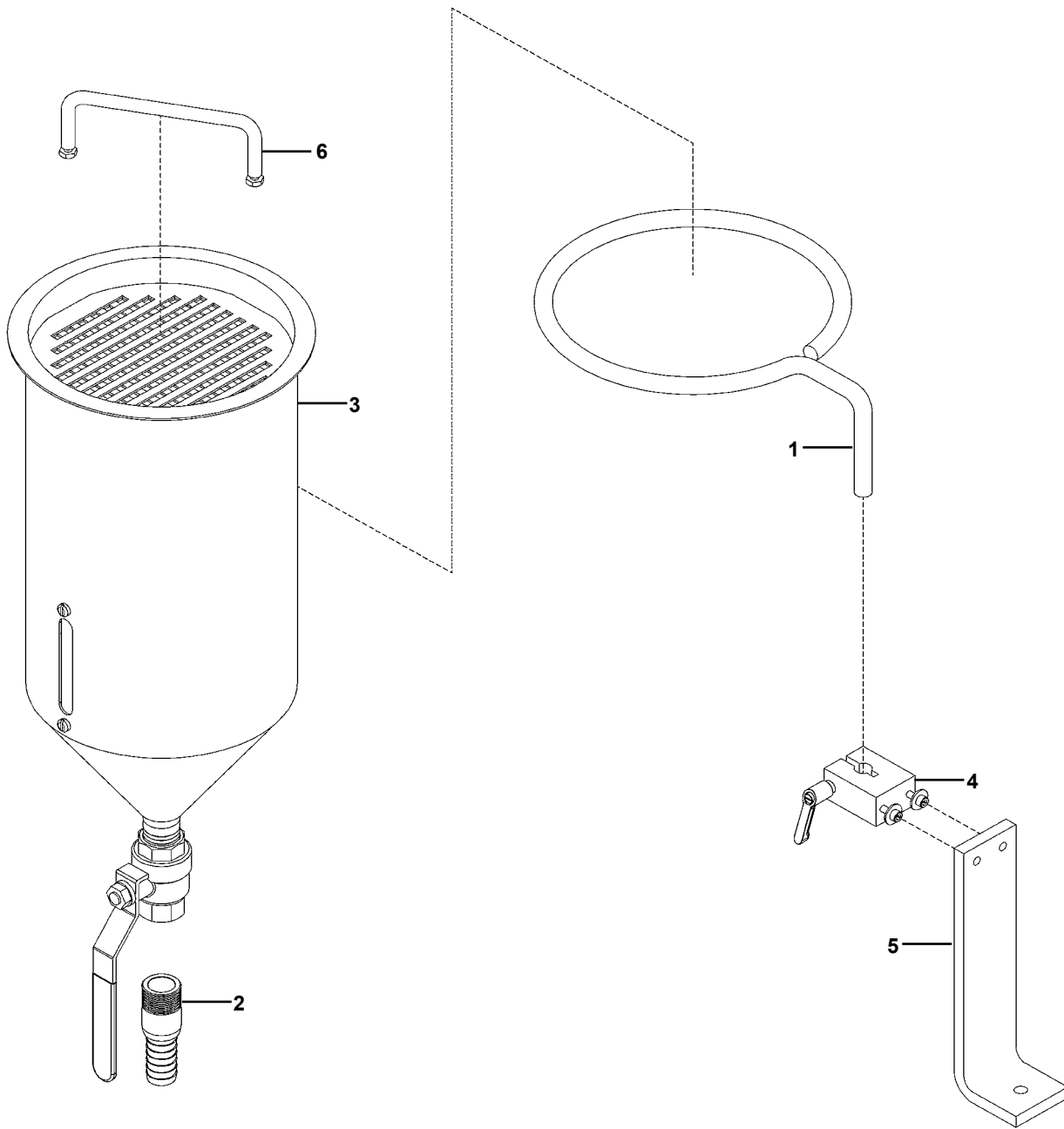

<u>ITEM</u>	<u>QTY</u>	<u>PART NO.</u>	<u>DESCRIPTION</u>
1	1	CWO-3757	Hopper Support Rod
2	1	CWO-3768	Hose Barb
3	1	CWO-3769	Flux Hopper Steel 12"
4	1	CWO-3770	1/2" Clamp Block
5	1	CWO-3773	Mounting Bracket Flux
6	1	GOF-3019	Handle w/Bolts
N/S	48"	1000-4-001	3/4" I.D. x 1" O.D. PVC/CLR Hose

CWO-3690-_ K231 SUBARC GUN ASSEMBLY / EXPLODED VIEW / PARTS LIST

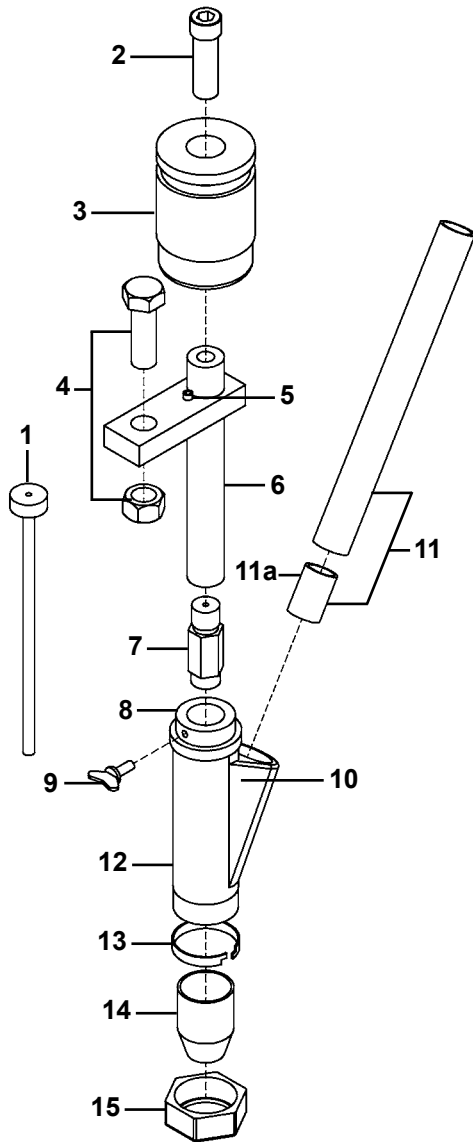

<u>ITEM</u>	<u>QTY</u>	<u>PART NO.</u>	<u>DESCRIPTION</u>
1	1	PXS-15106-3/32	Nozzle Insert
2	1	PXT-10570	Socket Head Screw
3	1	PXS-10493-1	Nozzle Insulator
4	1	PXS-121312	Hex Hd Scr 1 1/2" & Nut 1/2"-13
5	1	PXT-9967-10	Nozzle Body Roll Pin
6	1	CWO-8052	Nozzle Body
7	1	PXS-10125_	Contact Tip (Specify Wire Size)
8	1	PXS-10138	Flux Cone Plug (Insulator)
9	1	PXT-9078-1	Thumb Screw
10	1	PXT-9967-30	Flux Cone Roll Pin
11	1	PXT-13835	3/4" X 7" Flux Hose W/Fbr Ins
11A	1	PXT-3835-IN	Fiber Insulator
12	1	BUG-3161-P	Cone Body Assembly
13	1	BUG-3163	Locking Ferrule
14	1	BUG-3164	Flux Cone (KP2085-1)
15	1	BUG-3165	Retaining Nut

***WIRE SIZES AVAILABLE:**

PART #	WIRE SIZE
CWO-3690-1/16	1/16" (1.6 mm)
CWO-3690-5/64	5/64" (2.0 mm)
CWO-3690-3/32	3/32" (2.4 mm)

***REPLACEMENT CONTACT TIPS AVAILABLE:**

PART #	WIRE SIZE
AFW-2291	1/16" (1.5 mm)
CWO-8048	5/64" (2.0 mm)
CWO-8049	3/32" (2.4 mm)

CWO-3700- SUBARC GUN ASSEMBLY / EXPLODED VIEW / PARTS LIST

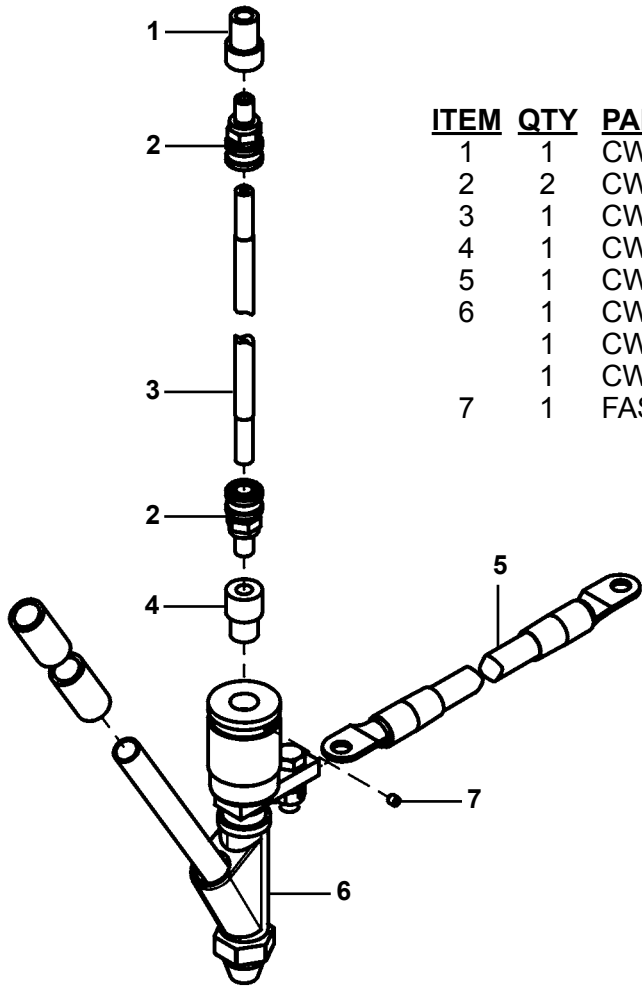

<u>ITEM</u>	<u>QTY</u>	<u>PART NO.</u>	<u>DESCRIPTION</u>
1	1	CWO-3698	Adaptor-LN7
2	2	CWO-1817	Bulk Head Connector QCB
3	1	CWO-3697	QCC 72" (1829 mm) Liner
4	1	CWO-3695-1/2	Adaptor K231 1/2"
5	1	CWO-3670-72	Weld Cable 4/0 Assy 72" (1829 mm) Lg
6	1	CWO-3690-1/16	Sub-Arc Nozzle 1/16"
	1	CWO-3690-5/64	Sub-Arc Nozzle 5/64"
	1	CWO-3690-3/32	Sub-Arc Nozzle 3/32"
7	1	FAS-0452	Set Scr 1/4-20 x 1/4

CW-5AX DRIVE ROLL KITS

PART NUMBER	DESCRIPTION
CWO-7026-.035	DRIVE ROLL KIT .035 (0.9mm) SOLID WIRE
CWO-7026-.035C	DRIVE ROLL KIT .035 (0.9mm) CORED WIRE
CWO-7026-.052	DRIVE ROLL KIT .045-.052 (1.0-1.3mm) SOLID WIRE
CWO-7026-.052C	DRIVE ROLL KIT .045-.052 (1.0-1.3mm) CORED WIRE
CWO-7026-1/16	DRIVE ROLL KIT 1/16 (1.6mm) SOLID/CORED WIRE
CWO-7026-3/32	DRIVE ROLL KIT .068-3/32 (1.7-2.4mm) SOLID/CORED WIRE

ACCESSORIES

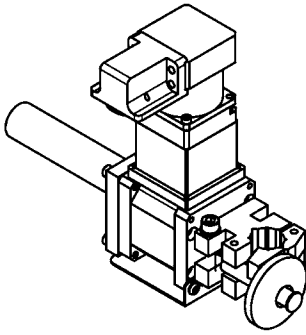

KBUG-5050 Stand Alone Weaver

The compact oscillator provides a pendulum weaving motion to the gun. Speed, width and dwells are independently adjustable.

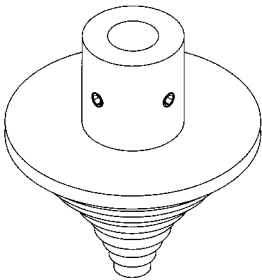

CWO-3670 Step Adaptor

The Step Adaptor is a stepped centering device used to center the machine on threaded I.D. couplings. The range of the Step Adaptor is 1/2" to 4" (13-102 mm) diameter.

CWO-3675 Groove Adaptor

For groove outlets of the following sizes: 1-1/4" (31.75 mm), 1-1/2" (38.1 mm), 2" (50.8 mm), 2-1/2" (63.5 mm), 3" (76.2 mm), 4" (101.6 mm)

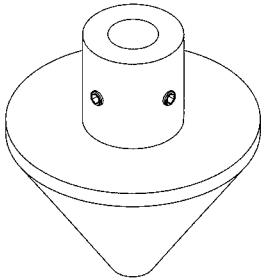

CWO-5790 Cone Adaptor

The Cone Adaptor is a tapered centering device used to center the machine on pipe stubbies. The range of the Cone Adaptor is 1-1/4" to 4" (32-102 mm) diameter.

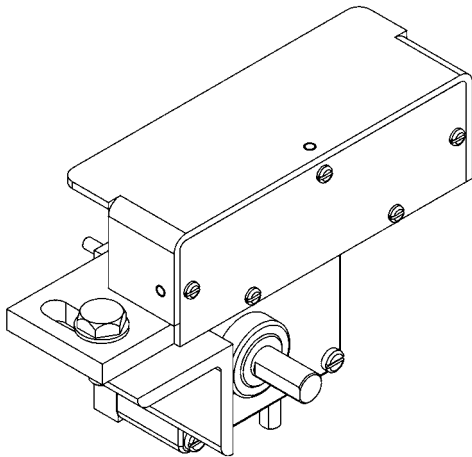

CWO-3894 HILLSIDE KIT

The CWO- 3894 Hillside Kit provides a *single* rise and fall motion per revolution of the machine to provide the motion required to follow the contour of an *offset* pipe-to-pipe weld. During standard operation, the cam mechanism of all Bug-O Welders provides a *dual* rise and fall action per revolution to follow the contour of a pipe-to-pipe weld. Once the Hillside kit is installed on a Bug-O circle welder, the operator can easily engage or disengage it to switch between single or dual rise and fall operation.

CARRIAGES

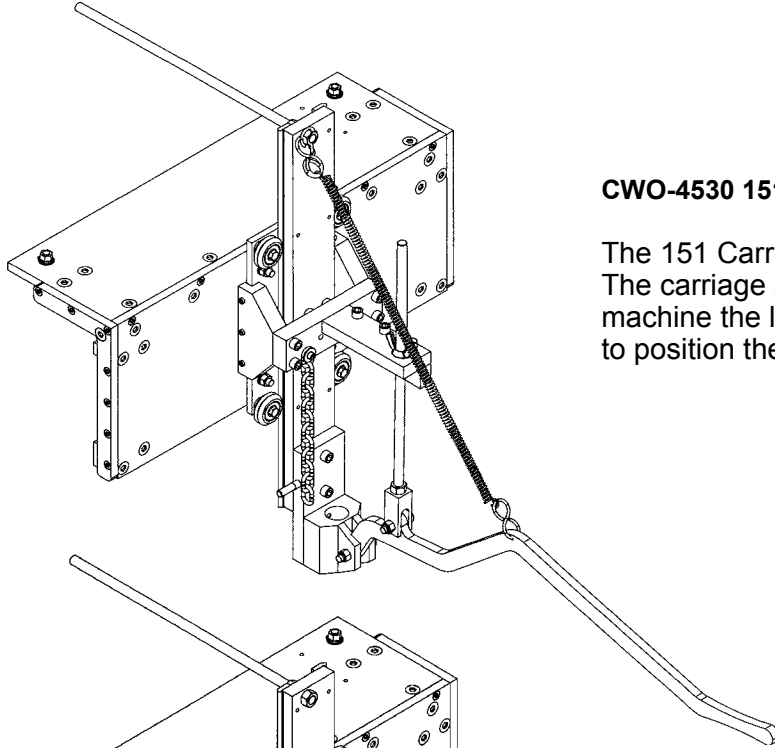

CWO-4530 151 Carriage

The 151 Carriage mounts on a standard monorail. The carriage allows the operator to move the machine the length of the pipe, while utilizing a lever to position the machine vertically on the work piece.

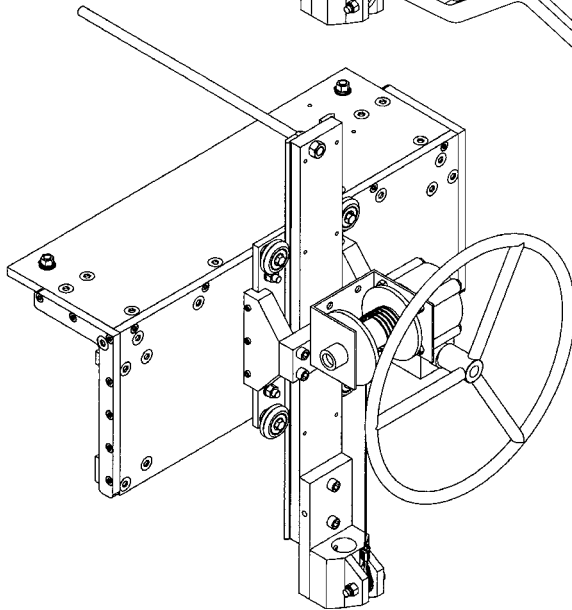

CWO-4540 151P Carriage

The 151P Carriage mounts on a standard monorail. The carriage allows the operator to move the machine the length of the pipe, while utilizing a winch to position the machine vertically on the work pieces.

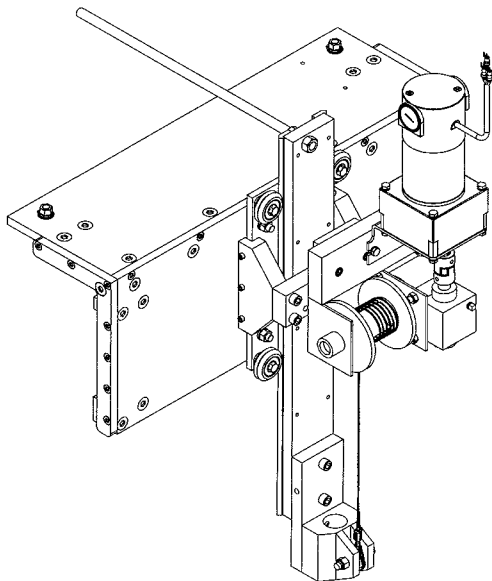

CWO-4550 151M Carriage

The 151M Carriage mounts on a standard monorail, or "bridge crane" type setups. The carriage allows the operator to move the machine the length of the pipe, while utilizing an electric motor to mechanically position the machine vertically on the work piece.

3-JAW EXPANDABLE CHUCKS

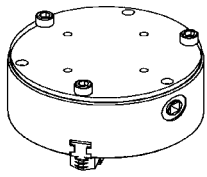

CWO-3660

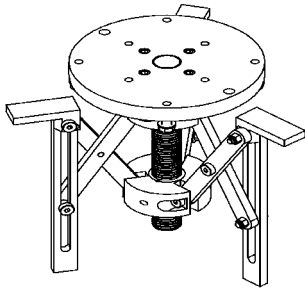

CWO-3661

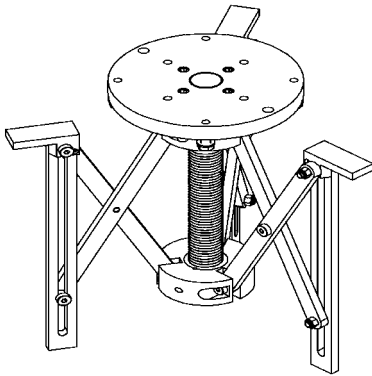

CWO-3662

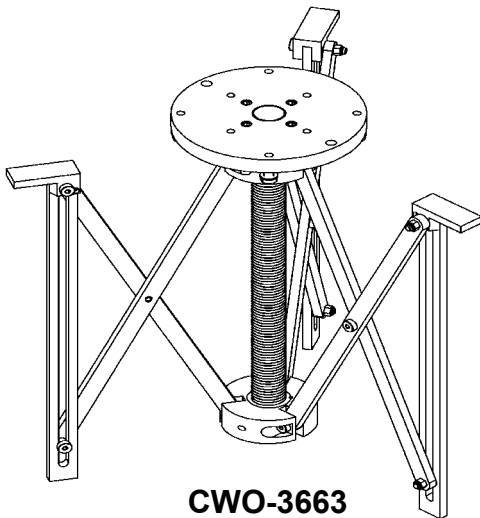

CWO-3663

3-Jaw Expandable Chucks

Mounts and automatically centers the Circle Welder on nozzles with or without flanges. As shown below.

PART NUMBER	FOR NOZZLE I.D.'S	WEIGHT
CWO-3660	2"-8" (51-204mm)	68 lbs. (31 kg)
CWO-3661	8"-16" (204-405 mm)	36 lbs. (16 kg)
CWO-3362	10"-24" (255-610 mm)	51 lbs. (23 kg)
CWO-3663	24"-42" (610-1065 mm)	64 lbs. (29 kg)

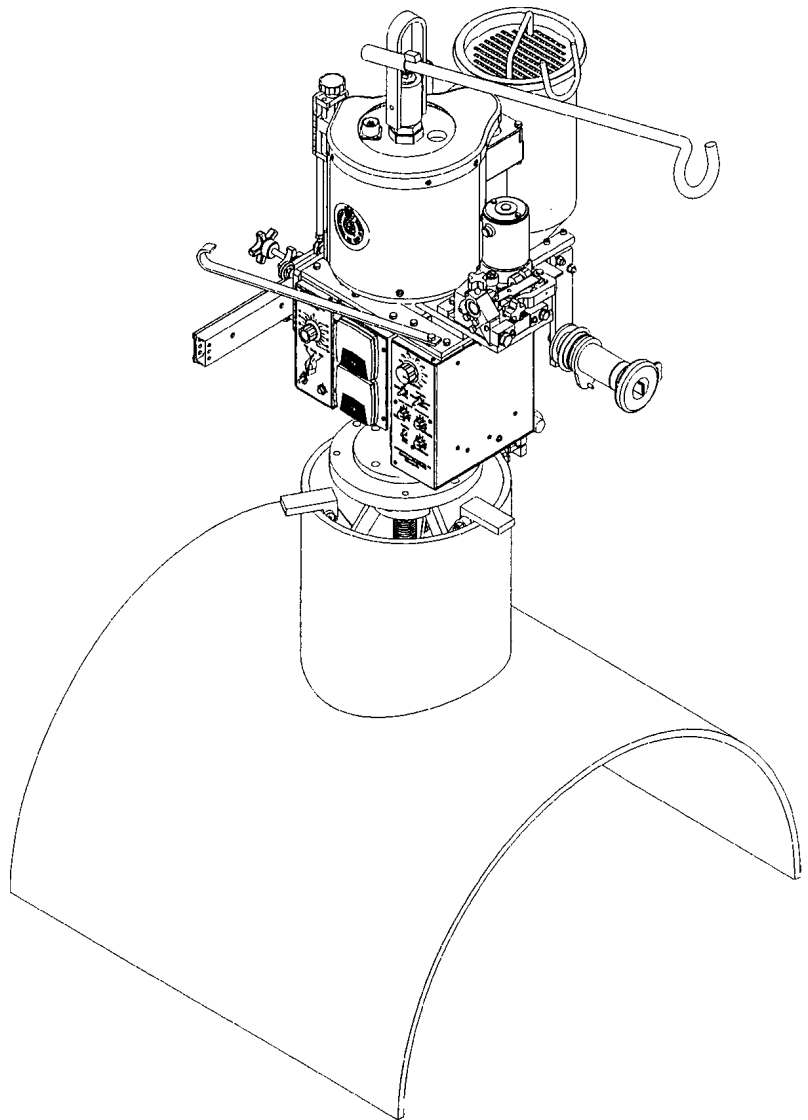

SETUP INSTRUCTIONS FOR CW-5AX / CB-1P USED IN SPRINKLER FABRICATION

SUPPORTING FIXTURE AND PIPE STANDS:

The first priority should be given to where the fixture is to be placed. The burning of the holes and welding of the couplings should be the last part of the operation performed on the pipe. It is important that a flow pattern or line be looked at, so that when the pipe is taken out of the fixture, it is finished and ready for shipment.

The mono rail consists of a 4" x 8" x 1/4" wall rectangular tubing with a 3/8" x 3" flat bar welded to the tubing (See pg. 30). The flat bar has to project 1" above the top of the tubing. "C" clamps are to be used to hold the flat bar against the tubing with no gaps. The "C" clamp may be walked down the tubing as it is being tack welded. If the beam has a bow greater than 1/32" in a 30' span in it, take to following steps:

1. Determine exactly where the center of the bow is. This may be accomplished by putting a string along the front side of the monorail. Place 1/2" nuts between the string and the monorail and measure the gap between the string and the monorail. Always measure on the same side of the string.
2. After you have determined where center of the bow is, take a hand torch and heat the outside of the bow. The outside of the bow should be the side the flat bar is welded to. Take a piece of chalk and draw a triangle with a 2" base under the bottom of the flat bar with the top or point of the triangle pointing down. Do the same on the top of the monorail against the flat bar with the top or point pointing towards the face of the monorail. Heat these two areas so that they become cherry red in color. After the heat has been applied, take a large rag and a bucket of water and cool the heated area. After the area has been cooled, check the beam again. Repeat as necessary.

PIPE STANDS

The pipe stands consist of 3" pipe in floor flanges with a 2-1/2" or 3" angle welded to the top of the pipe, and they should be spaced and aligned as shown (See pg. 30). The two stands should have some sort of clamping device to hold the pipe in place. The clamping device can be anything from a pipe vise to a chain and boom. The clamping device must be staggered.

After the pipe stands and supporting columns are in place, the monorail is to be placed on the supporting columns. The pipe stands and the supporting columns must be level and plumb. These items may have to be shimmed. With these items level, the monorail may be put in place on the supporting columns and held in place by two "C" clamps. Put a level on the face of the beam in the vertical position and on the bottom in the horizontal position. The beam should be level both ways, and if not, the beam will have to be shimmed. If the monorail has a twist, which may occur, level one end so that the other end needs to be pulled back.

Next, put a piece of 8" pipe in the pipe stands and clamp down. Take a centering head and find the center of the pipe on each end and in the middle. You can now use two methods to check to see if the monorail is aligned with the pipe below. They are as follows:

1. Use a plumb bob off the face of the monorail and measure from the center of the pipe to the plumb bob. The distance should be 5-11/16" in all three locations.
2. The second method is to put one carriage on the monorail and attach the CB-1P to it. With the center pin in the burning machine, check all three locations. The burning machine must be plumb on the carriage if this method is used.

SETUP INSTRUCTIONS FOR CW-5AX / CB-1P USED IN SPRINKLER FABRICATION

INSTALLING CARRIAGES AND MACHINES ON THE MONORAIL:

Assemble carriages and put them on the rail.

The CW-5AX welder is put on the carriage that is nearest to the welding power source and the CB-1P cutter nearest to the plasma power source.

Put the CB-1P cutter machine on the 8" pipe in the stands and bring the carriage to the machine. Lower the shaft coupling over the main shaft on the cutter. Ensure that shaft is fully inserted into the shaft coupling. Rotate the machine so that the plasma leads are in front and parallel to the carriage and tighten the set screws in the shaft coupling to secure the main shaft to the vertical slide assembly.

Next put the CW-5AX welder on the 8" pipe and bring its carriage to it. Lower the shaft coupling down over the main shaft. Rotate the machine so that the welding lead on top of the machine will be on your left. This will put the electrical connector on the right. Tighten the set screws in the shaft coupling to secure the main shaft to the vertical slide assembly.

It is important for the machines to hang plumb. Left to right adjustments are made by loosening the two bolts that connect the shaft coupling to the vertical rail. Front to back adjustments are done by adjusting the position of the vertical rail support plate. Move the plate by adjusting the eight nuts on the four studs.

Note: Once machines are plumb verify that the machines are centered over the pipe stand.

CARRIAGE ADJUSTMENT:

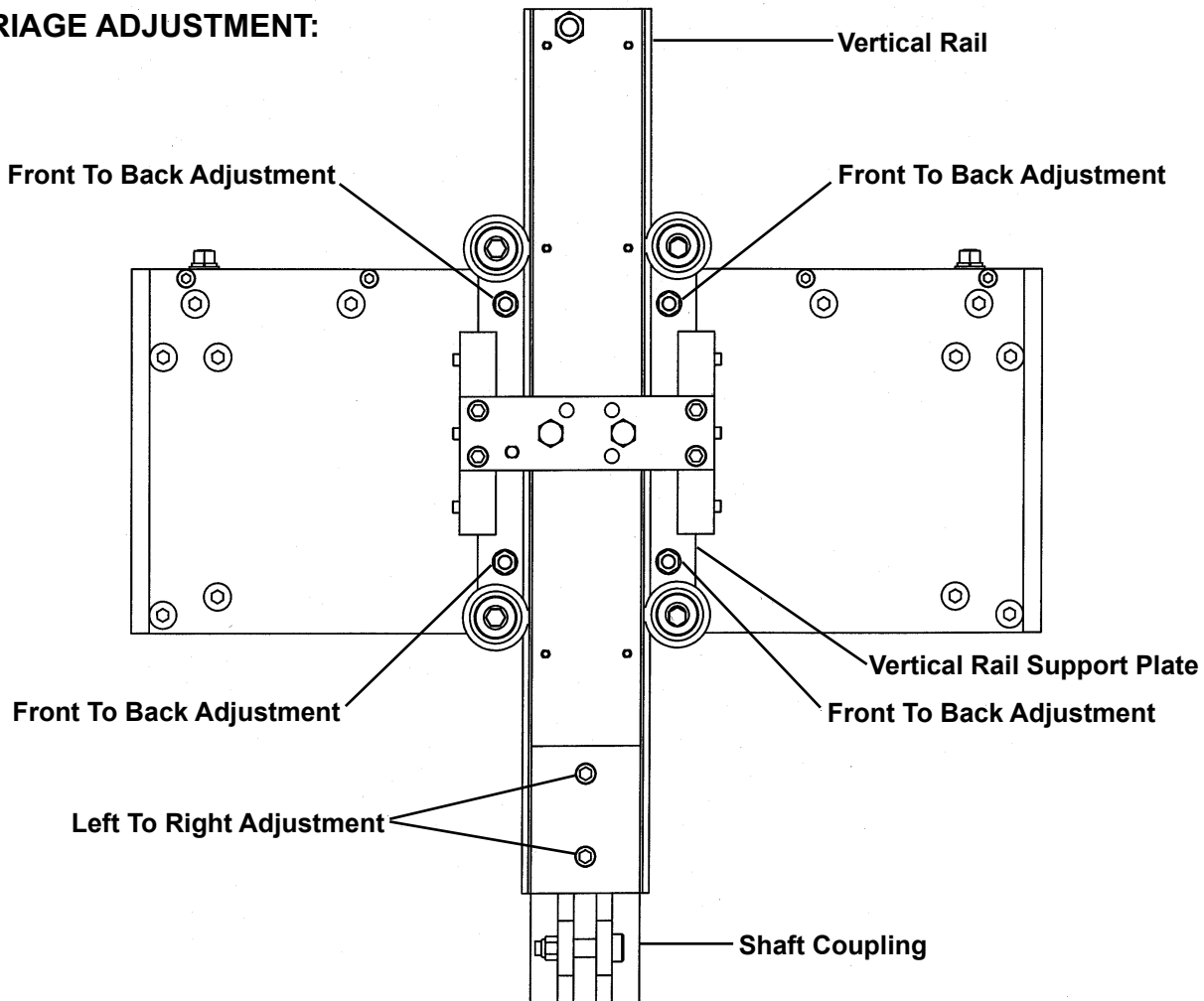

SUGGESTED SETUP DIAGRAM FOR CW-5AX / CB-1P USED IN SPRINKLER FABRICATION

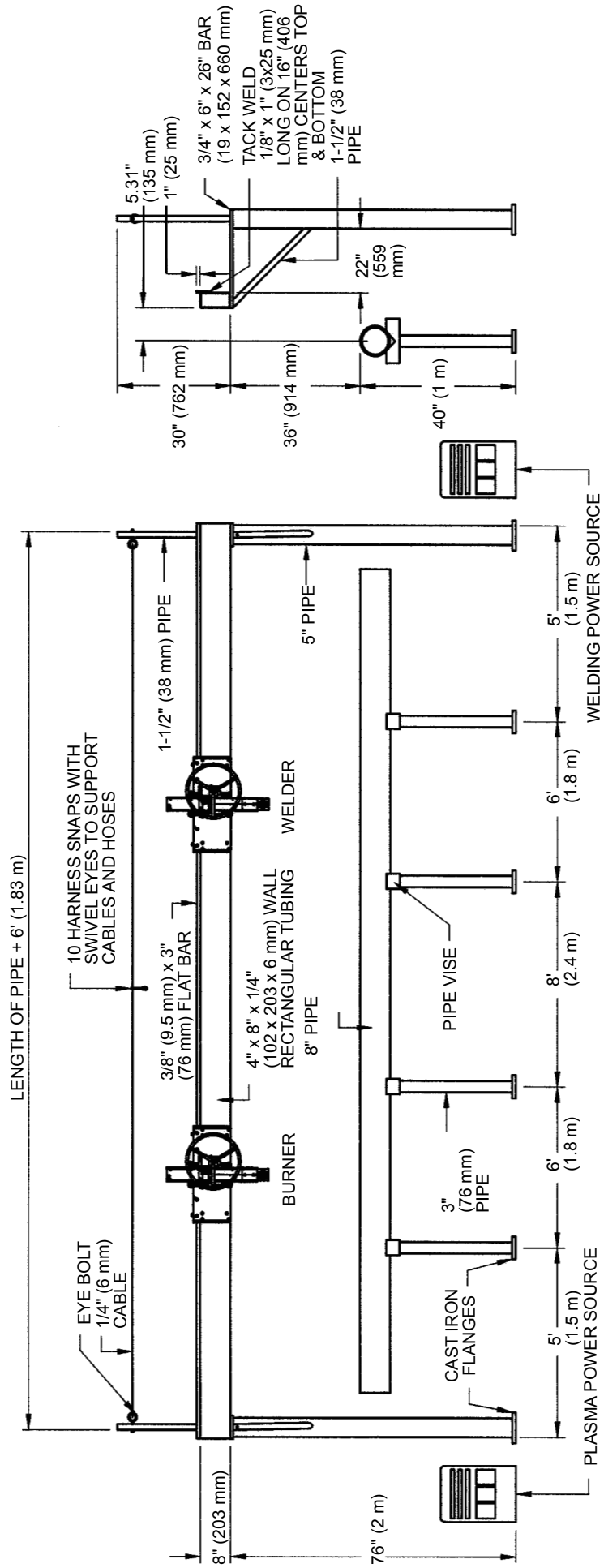

PREVENTIVE MAINTENANCE / CW-5AX CIRCLE WELDER

IMPORTANT: Make sure the input power at the power source is turned off and the 50' weld cable is disconnected from the circle welder prior to working inside the circle welder.

AFTER DAILY USE:

Refer to CW-5AX Exploded View Parts List. (Pg. 11)

Racking System Item #1:

Inspect gear rack, hardened ways and wheels (remove all dirt, grease, weld spatter and rust). Check hardened ways for nicks and replace if necessary. Lubricate with a dry teflon or graphite spray lubricant. Adjust wheels for snug fit and smooth operation. Lubricate racker pinion with a dry teflon or graphite spray lubricant.

Small Vertical Racker Item #2:

Inspect wheels (remove all dirt, grease, weld spatter and rust). Adjust wheels for snug fit and smooth operation. Lubricate racker pinion and wheels with a dry teflon or graphite spray lubricant.

Slide Bar Mounting Assembly Item #20:

Inspect hardened ways (remove all dirt, grease and weld spatter). Check hardened ways for nicks and replace if necessary. Lubricate with a dry teflon or graphite spray lubricant.

Refer to CW-5AX Electrical Component Chart. (Pg. 13)

Power Cable Item #4:

Inspect cable connector to make sure threads are not stripped and that the connector is not cracked. Check the cable for cuts, missing insulation and burn spots, replace if necessary.

CW-5AX Collector Ring Item #5:

Inspect cable connector to make sure threads are not stripped and that the connector is not cracked. Ensure that the connector is fastened properly to the large aluminum gear item #30 on the CW-5AX Exploded View Parts List.

EVERY SIX MONTHS:

Refer to CW-5AX Exploded View Parts List. (Pg. 11)

Aluminum Gear Item #30

Do not grease this gear. Inspect gear teeth (remove all dirt, grease and weld spatter). Lubricate with a dry teflon or graphite spray lubricant. Replace gear if excessively worn.

P.M. Motor Assembly Item #14:

Do not grease this pinion. Inspect the drive pinion (remove all dirt, grease and weld spatter). Lubricate with a dry teflon or graphite spray lubricant. Replace pinion if excessively worn. Check set screw and tighten if necessary. Adjust motor assembly using the four adjustable mounting fasteners so that proper gear mesh is achieved between the aluminum gear item #30 and the motor drive pinion.

4" Cam Assembly Item #5:

Inspect the slide rails and the cam pinion (remove all dirt, grease and weld spatter). Do not grease slide rails or cam pinion. Lubricate with a dry teflon or graphite spray lubricant. Replace cam pinion if excessively worn. Tighten all fasteners as needed.

Wire Wheel Assembly Item #6:

Periodically coat the wire wheel shaft with a thin layer of grease as needed. Inspect the shoe assembly and replace if excessively worn.

PREVENTIVE MAINTENANCE / CW-5AX CIRCLE WELDER

Refer to CW-5AX Electrical Component Chart. (Pg. 13)

GMA Wire Feed Control Item #7:

Open control box, use an air hose to blow out dust and dirt. Check all wires for breaks and replace if necessary. Check all electrical connectors and plugs. If an electrical component fails refer to CWO-3332 Wire Feeder Control electrical component chart for replacement parts or return for service.

M-14 Rotation Control Item #13:

Open control box use an air hose to blow out dust and dirt. Check all wires for breaks and replace if necessary. Check all electrical connectors and plugs. If an electrical component fails refer to CWO-6210 Rotation Control electrical component chart for replacement parts or return for service.

LN-7 Wire Feeder Assembly Item #10:

Check brushes for wear. Brushes should be replaced when their length is less than 1/4 inch. Replace strain relief on wire if pulled out of motor housing.

Large Brush Holder & Support Item #3:

Inspect brush holder. Make sure constant tension is being applied on the brushes. Brushes should move freely within the brush holder. Check brushes for arc build-up. If brushes are pitted they will need replaced. Remove the brushes and sand them to ensure a smooth contact surface. Make sure all fasteners are tight.

Small Brush Retainer Assembly Item #9:

Inspect black brush holders for cracks and replace if needed. Check and make sure all wires are soldered properly to the holders. Replace the brushes when their length is less than 1/2 inch long. Remove the brushes and sand them to ensure a smooth contact surface. Make sure all fasteners are tight.

Terminal Block Item #12:

Inspect the plastic terminal strip and make sure it is not cracked, replace if necessary. Make sure all terminal connections are tight. Make sure all ground wires are connected to the mounting screws of the terminal strip.

EVERY TWELVE MONTHS:

Refer to CW-5AX Exploded View Parts List. (Pg. 11)

1" Bearing With Fasteners Item #24:

Do not grease the bearing, it is greased for life by the manufacturer. If the grease fitting has not been removed and plugged we suggest that you do so now. Earlier models may not have been plugged at time of assembly.

1-1/4" Bearing With Fasteners Item #25:

Do not grease the bearing, it is greased for life by the manufacturer. If the grease fitting has not been removed and plugged we suggest that you do so now. Earlier models may not have been plugged at time of assembly.

P.M. Motor Assembly Item #14:

Bodine gear motor lubrication. Fill gear motor to oil level indicator with worm gear oil conforming to AGMA#5EP compounded (SAE#90) oil or Bodine lubricant (#L-23). Do not overfill.

LN-7 Wire Feeder Assembly Item #21:

Apply graphite grease to the gear teeth. Inspect the drive roll portion of the assembly, clean as necessary. Do not use solvents on the idle roll because it may wash the lubricant out of the bearings. Do not apply grease to the drive rolls.

Transmission 3.5:1 Assembly Item #17:

Inspect for excessive wear and tear. Keep the transmission assembly clean and lubricate with Lubriplate #630-AA.

PREVENTIVE MAINTENANCE / CW-5AX CIRCLE WELDER

Refer to CW-5AX Electrical Component Chart. (Pg. 13)

CW-5AX Collector Item #5:

The collector ring should be sanded once a year. If the collector ring is pitted too badly it should be replaced. Inspect all wires coming out of the collector ring for cut or missing insulation. All wires should be fastened to the center shaft with a nylon cable tie. Tighten four set screws if needed.

Weld Cable Inlet 3/0 Item #12:

Ensure that the cable is fastened tightly to the collector ring. Inspect the cable for cut or missing insulation. Make sure the micarta insulation tube on the cable is in good condition. Replace the cable if necessary.

Solenoid Adaptor Kit Item #15:

Inspect for damage. Replace if necessary.

GMA Pigtail Item #6:

Inspect the cable for cuts or missing insulation. Ensure that the elbow connector is not damaged. Ensure that all terminal ends are snug. Replace cable if necessary.

WARRANTY

Limited 3-Year Warranty

Model _____
Serial No. _____
Date Purchased: _____
Where Purchased: _____

For a period ending one (1) year from the date of invoice, Manufacturer warrants that any new machine or part is free from defects in materials and workmanship and Manufacturer agrees to repair or replace at its option, any defective part or machine. HOWEVER, if the invoiced customer registers the Product Warranty by returning the Warranty Registration Card supplied with the product within 90 days of the invoice date, or by registering on-line at www.bugo.com, Manufacturer will extend the warranty period an additional two (2) years which will provide three (3) total years from the date of original invoice to customer. This warranty does not apply to machines which, after Manufacturer's inspection are determined by Manufacturer to have been damaged due to neglect, abuse, overloading, accident or improper usage. All shipping and handling charges will be paid by the customer.

The foregoing express warranty is exclusive and Manufacturer makes no representation or warranty (either express or implied) other than as set forth expressly in the preceding sentence. Specifically, Manufacturer makes no express or implied warranty of merchantability or fitness for any particular purpose with respect to any goods. Manufacturer shall not be subject to any other obligations or liabilities whatsoever with respect to machines or parts furnished by Manufacturer.

Manufacturer shall not in any event be liable to Distributor or any customer for any loss of profits, incidental or consequential damages or special damages of any kind. Distributor's or customer's sole and exclusive remedy against Manufacturer for any breach of warranty, negligence, strict liability or any other claim relating to goods delivered pursuant hereto shall be for repair or replacement (at Manufacturer's option) of the machines or parts affected by such breach.

Distributor's Warranty:

In no event shall Manufacturer be liable to Distributor or to any customer thereof for any warranties, representations or promises, express or implied, extended by Distributor without the advance written consent of Manufacturer, including but not limited to any and all warranties of merchantability or fitness for a particular purpose and all warranties, representations or promises which exceed or are different from the express limited warranty set forth above. Distributor agrees to indemnify and hold Manufacturer harmless from any claim by a customer based upon any express or implied warranty by Distributor which exceeds or differs from Manufacturer's express limited warranty set forth above.

HOW TO OBTAIN SERVICE:

If you think this machine is not operating properly, re-read the instruction manual carefully, then call your Authorized BUG-O dealer/distributor. If they cannot give you the necessary service, write or phone us to tell us exactly what difficulty you have experienced. BE SURE to mention the MODEL and SERIAL numbers.