

INSTRUCTIONS and PARTS MANUAL

CB-2, CB-3 CIRCLE BURNER

Please record your equipment identification information below for future reference. This information can be found on your machine nameplate.

Model Number _____

Serial Number _____

Date of Purchase _____

Whenever you request replacement parts or information on this equipment, always supply the information you have recorded above.

LIT-CB2-CB3-IPM-0411



CYPRESS WELDING EQUIPMENT INC.

CE

A DIVISION OF WELD TOOLING CORPORATION

3001 West Carson Street • Pittsburgh, PA USA 15204-1899
Telephone: 1-412-331-1776 • 1-800-245-3186 • Fax: 1-412-331-0383
<http://www.cypressweld.com>

SAFETY

PROTECT YOURSELF AND OTHERS FROM SERIOUS INJURY OR DEATH. KEEP CHILDREN AWAY. BE SURE THAT ALL INSTALLATION, OPERATION, MAINTENANCE AND REPAIR PROCEDURES ARE PERFORMED ONLY BY QUALIFIED INDIVIDUALS.



ELECTRIC SHOCK CAN KILL.

- 1) The equipment is not waterproof. Using the unit in a wet environment may result in serious injury. Do not touch equipment when wet or standing in a wet location.
- 2) The unused connectors have power on them. Always keep the unused connectors covered with the supplied protective panels. Operation of the machine without the protective panels may result in injury.
- 3) Never open the equipment without first unplugging the power cord or serious injury may result.
- 4) Verify the customer supplied power connections are made in accordance with all applicable local and national electrical safety codes. If none exist, use International Electric Code (IEC) 950.
- 5) Never remove or bypass the equipment power cord ground. Verify the equipment is grounded in accordance with all applicable local and national electrical safety codes. In none exist, use International Electric Code (IEC) 950.

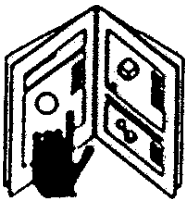

READ INSTRUCTIONS.

Read the instruction manual before installing and using the equipment.



EQUIPMENT DAMAGE POSSIBLE.

- 1) Do not plug in the power cord with out first verifying the equipment is OFF and the cord input voltage is the same as required by the machine or serious damage may result.
- 2) Always verify both the pinion and wheels are fully engaged before applying power or equipment damage may occur.
- 3) Do not leave the equipment unattended.
- 4) Remove from the worksite and store in a safe location when not in use.



FALLING EQUIPMENT can cause serious personal injury and equipment damage.

Faulty or careless user installation is possible. As a result, never stand or walk underneath equipment.



MOVING PARTS can cause serious injury.

- 1) Never try to stop the pinion from moving except by removing power or by using the STOP control.
- 2) Do not remove any protective panels, covers or guards and operate equipment.

HIGH FREQUENCY WARNINGS

SPECIAL PRECAUTIONS ARE REQUIRED WHEN USING PLASMA, TIG OR ANY WELDING PROCESS THAT USES HIGH FREQUENCY TO STRIKE AN ARC.



WARNING: HIGH FREQUENCY CAN EFFECT MACHINE OPERATION AND THEREFORE, WELD QUALITY.

Read the precautions below before installing and using the equipment.

PRECAUTIONS:

- 1) Some plasma or welding cables are strong sources of high frequency interference. NEVER lay a plasma or welding cable across the controls of the machine.
- 2) Always physically separate the plasma or welding cable leads from the machine cables. For example, the plasma or welding cable leads should NEVER be bundled with a pendant cable or the machine power cord. Maximize the separation between any machine cables and the plasma or welding cables.
- 3) Strictly follow the grounding procedures specified for the plasma or welding unit. NOTE: Some plasma and welding units produce exceptionally large amounts of high frequency noise. They may require a grounding rod be driven into the earth within six feet (2 meters) of the plasma or welding unit to become compatible with an automatic cutting or welding process.
- 4) If the high frequency is produced using a spark gap, adjust the points so the gap is as small as possible. The larger the gap, the higher the voltage and the higher the interference.
- 5) Some plasma or welding units will inject high frequency interference into the AC power line. Use separate power line branches whenever possible to power the plasma or welding source and the machine. Do not plug them into the same outlet box.
- 6) High frequency noise may enter the machine through the plasma or welding supply remote contactor leads. Some plasma and welding sources can produce noise spikes of up to several thousand volts. These sources are not compatible with automated cutting and welding equipment. It is recommended that the remote contactor leads on these plasma or welding sources not be connected to the machine. An alternate solution is to purchase a separate remote contactor isolation box.

CB-2, CB-3 CIRCLE BURNER

INSTRUCTIONS AND PARTS MANUAL

TABLE OF CONTENTS

PAGE

5Introduction
6Set-Up and Operation
7Making a Cut
8(CWO-3365) Rotation Control for CBO-2000
9Technical Data / Dimensions / CB-2 Circle Burner
10Technical Data / Dimensions / CB-3 Circle Burner
11CBO-2000 CB-2 Circle Burner / Exploded View / Parts List
12CBO-2000 CB-2 Circle Burner / Wiring Diagram
13CBO-3000 CBO-3002 CB-3 Circle Burner / Exploded View / Parts List
14CBO-3000 CB-3 Circle Burner / Wiring Diagram
15CWO-1635 Racking System CB-2, CB-3 / Exploded View / Parts List
15CWO-1690 Large Horizontal Racker / Exploded View / Parts List
16CWO-3193 Housing Assembly CB-2, CB-3 / Exploded View / Parts List
16CWO-3205 7" Cam Assembly / Exploded View / Parts List
17CWO-3358 CB-2, CB-3 Motor & Transmission Plate / Exploded View / Parts List
17CWO-3359 Transmission SW 5:1 / Exploded View / Parts List
18CWO-3361 P.M. Motor Assembly / Exploded View / Parts List
18CWO-3425 CB-2, CB-3 Camshaft & Spacer Assembly / Exploded View / Parts List
19CWO-3501 CB-2, CB-3 Shaft Assembly / Exploded View / Parts List
19CWO-3920 Slide Bar Mounting Assembly / Exploded View / Parts List
20CWO-3960 CB-2, CB-3 Small Brush Assembly / Exploded View / Parts List
20CWO-3961 CB-2, CB-3 Small Retainer Block / Exploded View / Parts List
21CWO-6110 Rotation Control / Exploded View / Parts List
22CWO-6110 Rotation Control / Wiring Diagram
23CWO-3073 CB-2 Frame / Exploded View / Parts List
24Accessories / CWO-3744 Manipulator Bracket / CWO-3744 Manipulator / Exploded View / Parts List
25Preventive Maintenance / CB-2, CB-3 Circle Burner
27Warranty

INTRODUCTION:

The CB-2 (CBO-2000) Circle Burner uses oxy-fuel for square or beveled hole cuts using a single cutting pass. The CB-2 is mounted on a special frame with a releasable permanent magnet base specially designed for use on vessels and large diameter pipe.

The CB-3 (CBO-3000) Circle Burner also uses oxy-fuel for single pass, square or beveled hole cuts. Mounted on a column and boom, manipulator or fixture, the CB-3 is designed for use on vessels, large diameter pipe, domed heads and flat plate.

Features:

- 1-1/2 h.p. P.M. Motor and rotational speed control.
- Rotation speed of 0.1-2 r.p.m.
- 100% duty cycle.
- Adjustable vertical and horizontal torch positioning system.
- Rise and fall cam assembly with 7" (178 mm) of travel.
- 2 hose machine torch w / tip adjuster, includes tips.
- Cutting capacities: 1.5"-42" (38-1067 mm) bevel cut holes, 4"-48" (102-1219 mm) square cut holes.
- Brushes and collector rings for all controls, eliminates cable and hose wrap.



SET-UP AND OPERATION:

All page numbers referred to in this section are from this manual unless otherwise specified.

POWER SUPPLY: Uses standard 120/50-60/1 VAC.

OXY-FUEL CUTTING TORCH: The CB-2, CB-3 Circle Burner is equipped with a Victor 2-Hose Machine Oxy-Fuel Torch model 204-A w/rack. Refer to the Victor Oxy-Fuel Cutting Torch instruction manual supplied with this machine for general operation and set-up information.

FIXTURING: All circle burners (excluding CB-2) have to be fixtured in some manner from the top of the shaft. This may be achieved in one of the following; column & boom, manipulator or a fixture devise.

OXYGEN / FUEL CONNECTIONS: The CB-2, CB-3 Circle Burner is designed to accept standard oxy-fuel hose fitting connections. These connections are located at the top of the shaft on all models.

RISE AND FALL OF THE CAM: All circle burners are equipped with a rise and fall cam assembly. The came assembly must be aligned before any other settings can be made. To align the cam on the machine, align the horizontal rack parallel to the pipe (**on the CB-2 align the horizontal rack parallel to the frame with the torch next to the frame**). Adjust the gun holder so it is perpendicular to the horizontal rack. Loosen the set screws in the brass block on the cam, and rotate the cam to the vertical position as shown.

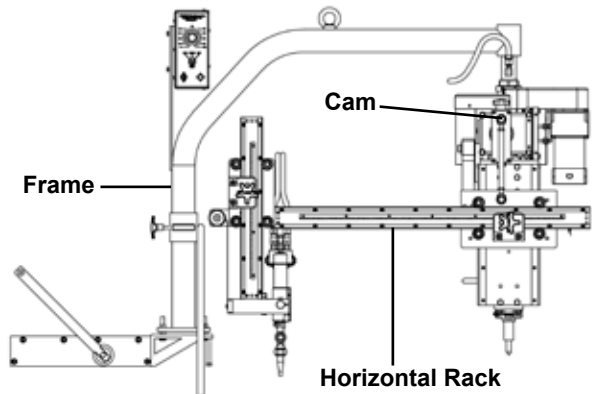

SETTING THE CAM: The cam setting is equal to the distance "B" subtracted from the distance "A".

EXAMPLE:

Let A=3 and B=2

$3-2=1$

The cam setting is 1.

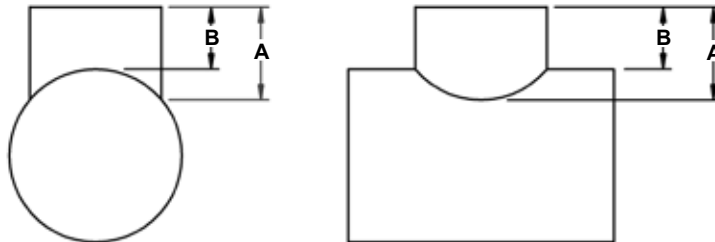

WHEEL ADJUSTMENT: The CB-2, CB-3 Racking System CWO-1635 (Item #3 page 11 or 13) and the Large Horizontal Racker CWO-1690 (Item #4 page 11 or 13) are equipped with adjustable wheels. Always check these components for proper wheel adjustment before using the machine. The wheels need adjustment if you can cock or wiggle the components out of alignment. The wheels should be snug but not prohibit movement along the path of travel. The wheels with the hex stand off are adjustable. To adjust the wheels loosen the hex bolt (A) until the adjustable bushing (B) can be rotated. Correct the wheel alignment by rotating the adjustable bushing (B). Once adjusted, hold the adjustable bushing (B) while tightening the hex bolt (A). Recheck alignment.

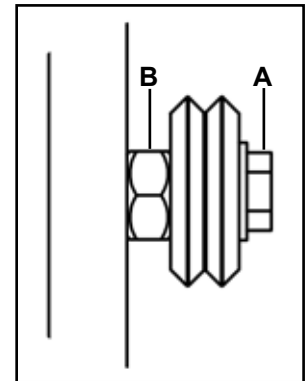

MACHINE CONTROLS: Various speed and directional capabilities can be controlled using the CWO-6110 Rotation Control. Please refer to CWO-6110 Rotation Control (page 21) section in this manual.

MAKING A CUT:

1. Position the torch to the starting location using the CWO-1635 Racking System. Ensure that the torch is at the appropriate position, standoff distance and angle.
2. Ignite torch. Refer to the torch manufacture instructions.
3. Preheat the spot were the cut is to be started. Before cutting action can start, the base metal must be preheated to a bright cherry red. When the red spot appears, depress the cutting oxygen lever slowly and firmly.
4. Start cutting rotation (forward or reverse) by using the Travel Direction Control located on the CWO-6110 Rotation Control (for operating instruction see page 8).
5. To stop the cutting processes and rotation, throw the oxygen lever to the "OFF" position and the travel direction control to the "BRAKE" position.

WARNING: IT IS NECESSARY TO USE CORRECT EYE, HEAD, AND BODY PROTECTION.

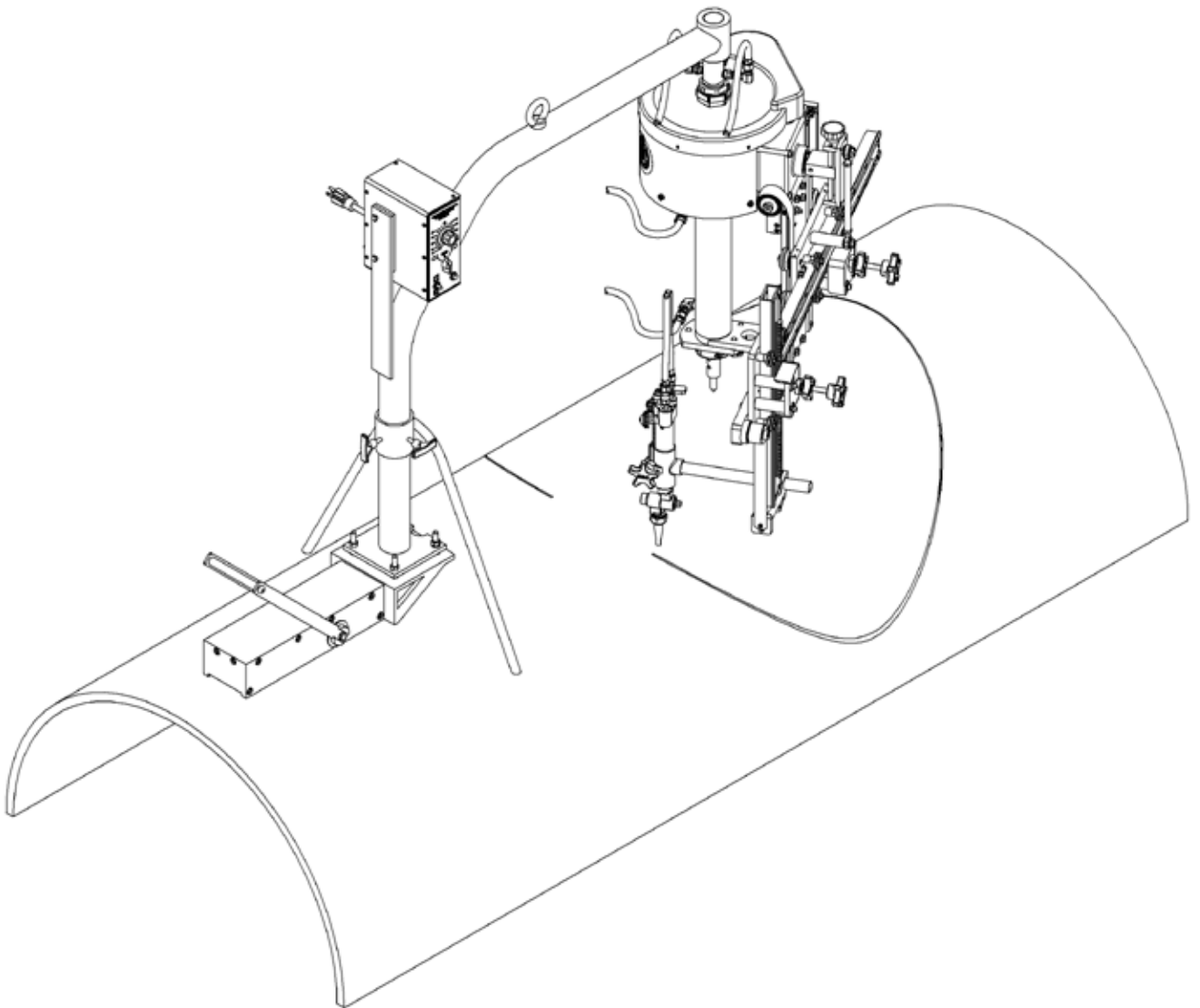

(CWO-3365) ROTATION CONTROL FOR CBO-2000

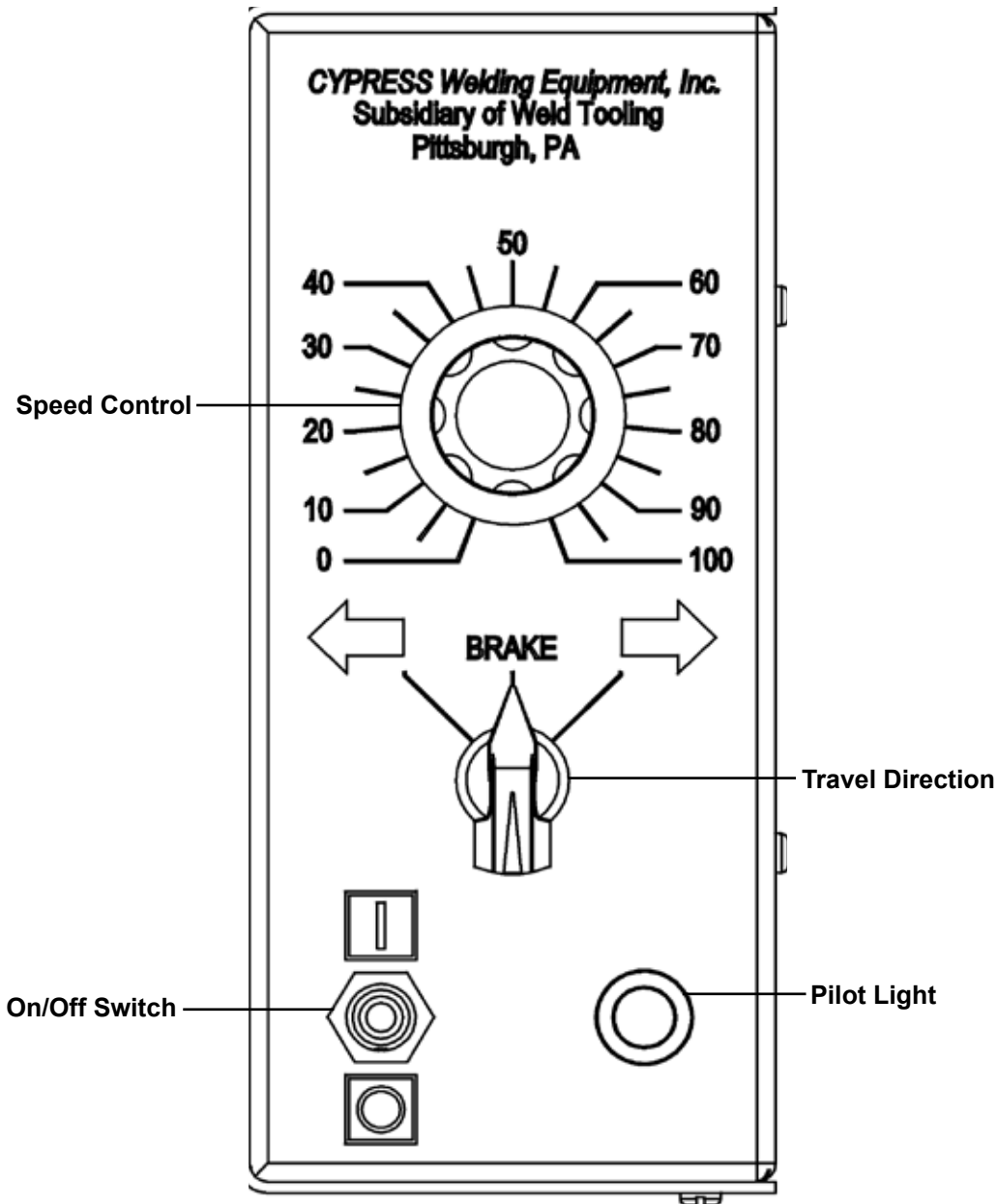

SPEED CONTROL:

Controls the speed in which the machine travels. The depicted lines 0 to 100 should not be construed as inches per minute of travel. They should be considered as reference points only.

TRAVEL DIRECTION:

Controls the direction in which the machine will travel. Select the left arrow for clockwise rotation, brake for stop, and the right arrow for counterclockwise rotation.

ON/OFF SWITCH:

The on/off switch enables/disables power to the rotation control box.

PILOT LIGHT:

The pilot light indicates whether the machine is on/off as dictated by the on/off switch.

TECHNICAL DATA: (CB-2 CIRCLE BURNER)

Rotation speed: 0.1-2 r.p.m.
Cam Range: 0-7" (0-178 mm)
Cutting Diameter: **For Square Cut Holes:** 4"-48" (102-1219 mm)
For Bevel Cut Holes: 1.5"-42" (38-1067 mm)
Height: 37" (940 mm)
Net Weight: 210 lbs. (95.3 kg)
Shipping weight: 290 lbs. (132 kg)

DIMENSIONS:

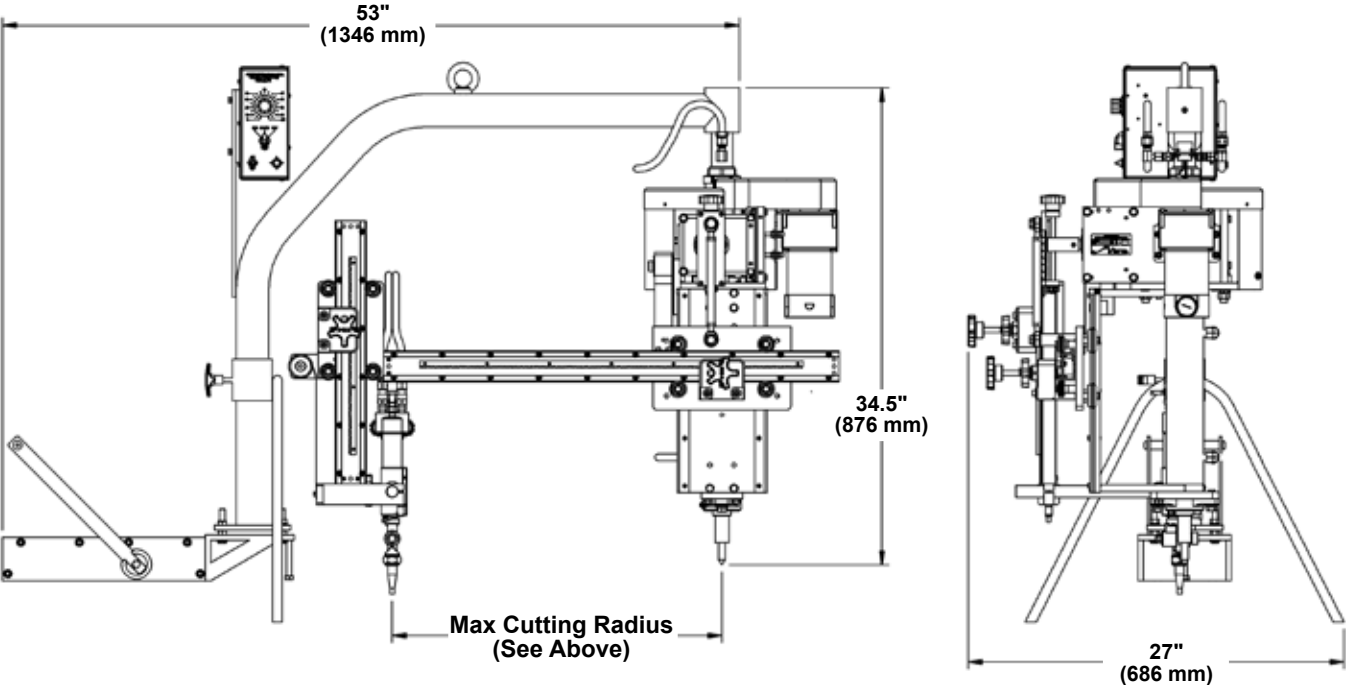

TECHNICAL DATA: (CB-3 CIRCLE BURNER)

Rotation speed: 0.1-2 r.p.m.

Cam Range: 0-7" (0-178 mm)

Cutting Diameter:

For Square Cut Holes: 4"-48" (102-1219 mm)

For Bevel Cut Holes: 1.5"-42" (38-1067 mm)

Height: 34.5" (876 mm)

Net Weight: 125 lbs. (56.7 kg)

Shipping weight: 230 lbs. (104 kg)

DIMENSIONS:

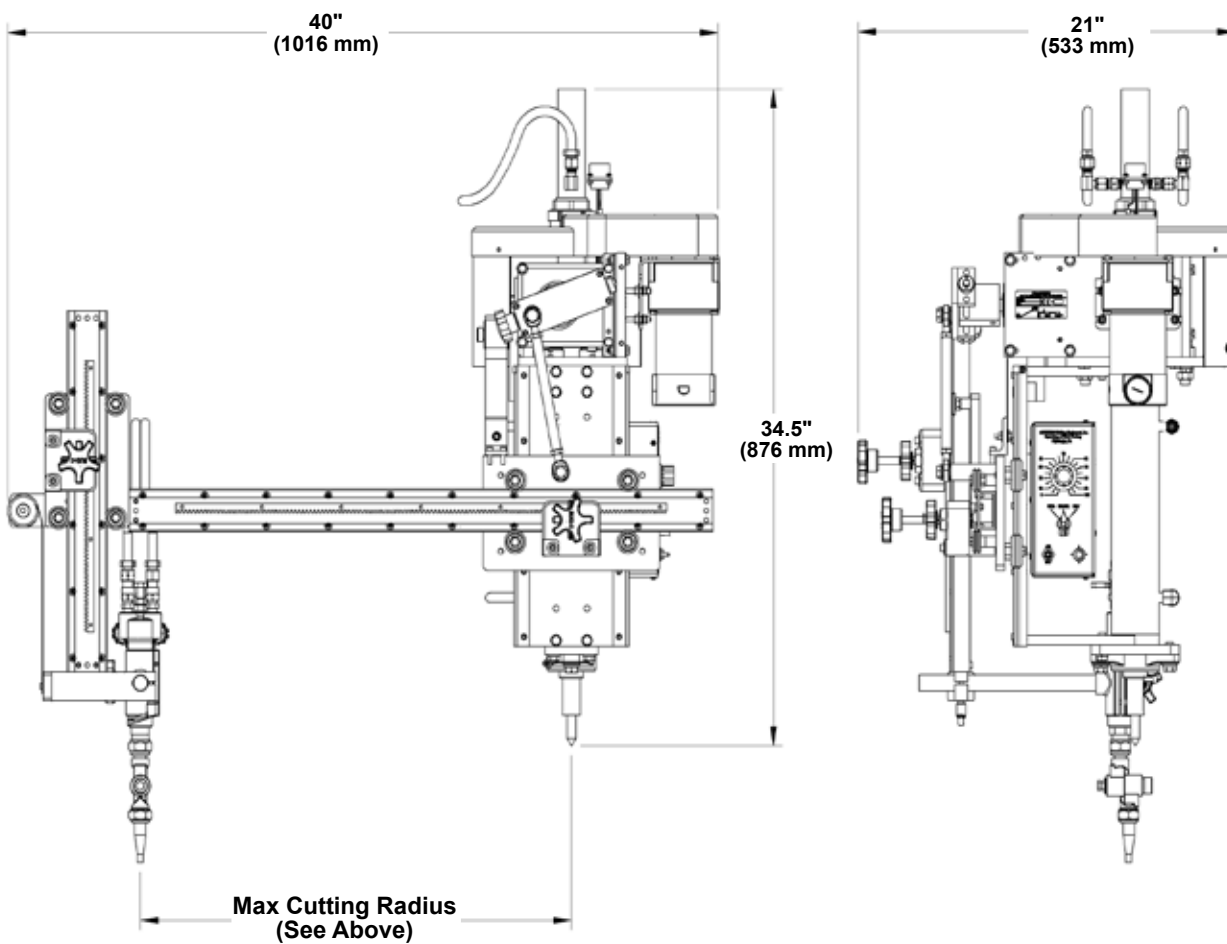

(CBO-2000) CB-2 CIRCLE BURNER / EXPLODED VIEW / PARTS LIST

ITEM QTY	PART NUMBER	DESCRIPTION
1	BUG-1259	Adjustable Tip Adaptor
1	BUG-1298	2-Hose Machine Torch
3	CWO-1635	Racking System CB-2, CB-3
4	CWO-1690	Large Horizontal Racker
5	CWO-3137	CB-2, CB-3 Guard Assy.
6	CWO-3193	CB-2, CB-3 Housing Assy.
7	CWO-3205	7" Cam Assembly
8	CWO-3358	CB-2, CB-3 Motor & Transmission Plt. Assy.
9	CWO-3359	Transmission SW 5:1 Assy.
10	CWO-3361	P.M. Motor Assembly #147
11	CWO-3366	CB-2, CB-3 Collector Ring Assy.
12	CWO-3425	CB-2, CB-3 Camshaft & Spacer Assy.
13	CWO-3445	Top Gear, Alum, CB-2
14	CWO-3501	CB-2, CB-3 Shaft Assy.
15	CWO-3920	Slide Bar Mounting Assy.
16	CWO-3935	Terminal Block Assy.
17	CWO-3960	CB-2, CB-3 Small Brush Retainer
18	CWO-3996	28" Oxygen Hose Assy.
19	CWO-3997	28" Fuel Hose Assy.
20	CWO-4050	1" Bearing w/Fasteners
21	CWO-4340	1-1/2" Flange Bearing
22	CWO-4910	16.5# Load Spring Assy.
23	CWO-5074	1-1/2" I.D. Trantorque
24	CWO-6116-K	Rotation Control Mounting Kit
25	CWO-3073	CB-2 Frame
26	CWO-3365	CB-2 Rotation Control
26	CWO-3365-240	CB-2 Rotation Control

(CBO-2000) CB-2 CIRCLE BURNER / WIRING DIAGRAM

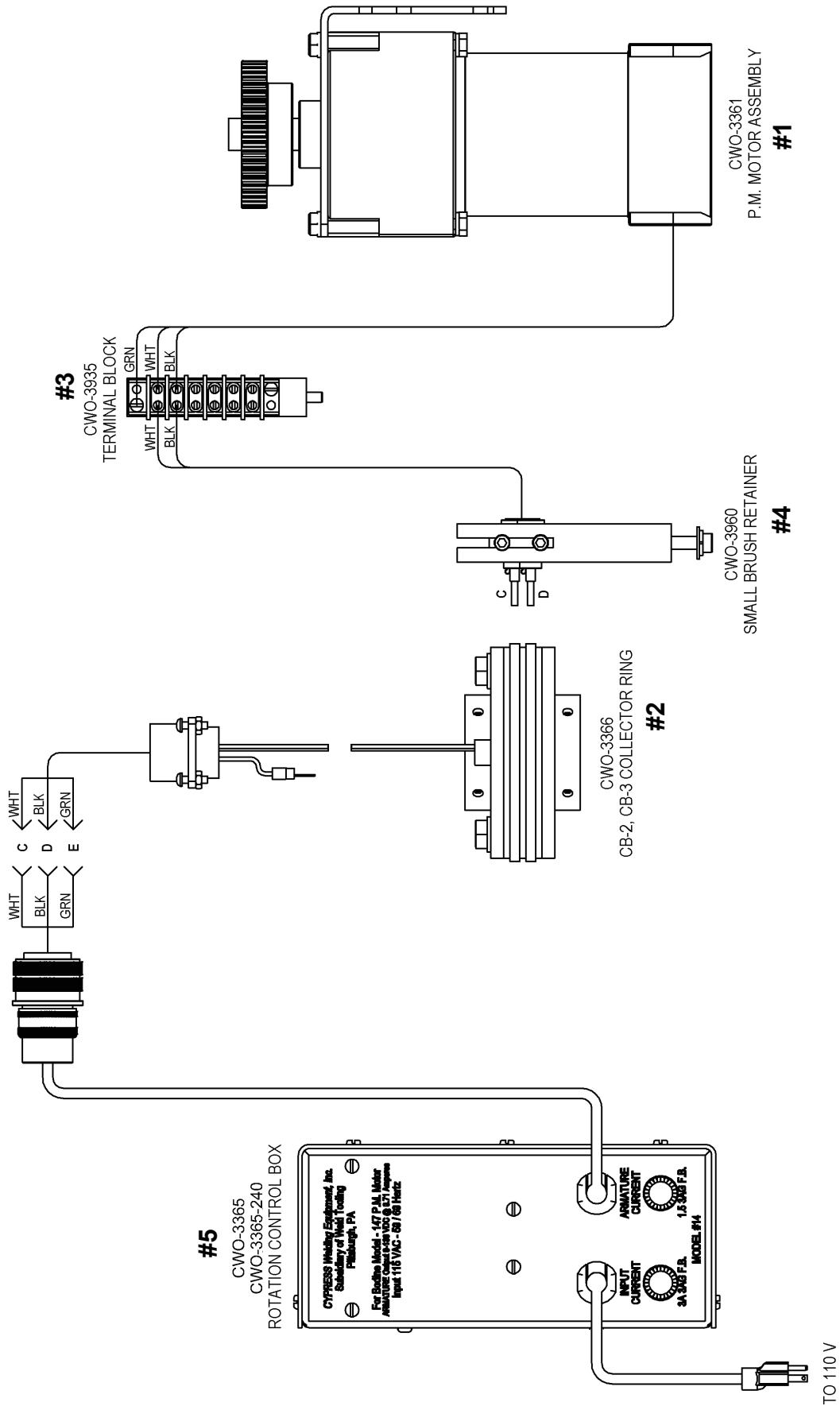

(CBO-3000 CBO-3002) CB-3 CIRCLE BURNER / EXPLODED VIEW / PARTS LIST

ITEM	QTY	PART NUMBER	DESCRIPTION
1	1	BUG-1259	Adjustable Tip Adaptor
2	1	BUG-1298	2-Hose Mechanical Torch
3	1	CWO-1635	Racking System CB-2, CB-3
4	1	CWO-1690	Large Horizontal Racker
5	1	CWO-3137	CB-2, CB-3 Plastic Guard Assy.
6	1	CWO-3193	CB-2, CB-3 Housing Assy.
7	1	CWO-3205	7" Cam Assy.
8	1	CWO-3358	CB-2, CB-3 Motor & Transmission PLT. Assy.
9	1	CWO-3359	Transmission SW 5:1 Assy.
10	1	CWO-3361	P.M. Motor Assy. #147
11	1	CWO-3366	CB-2, CB-3 Collector Ring Assy.
12	1	CWO-3425	CB-2, CB-3 Camshaft & Spacer Assy.
13	1	CWO-3445	Top Gear, Alum, CB-2
14	1	CWO-3501	CB-2, CB-3 Shaft Assy.
15	1	CWO-3920	Slide Bar Mounting Assy.
16	1	CWO-3935	Terminal Block Assy.
17	1	CWO-3960	CB-2, CB-3 Small Brush Retainer
18	1	CWO-3996	28" Oxygen Hose Assy.
19	1	CWO-3997	28" Fuel Hose Assy.
20	1	CWO-4050	1" Bearing w/Fasteners
21	1	CWO-4340	1/1/2" Flange Bearing
22	1	CWO-4910	16.5# Load Spring Assy.
23	1	CWO-5074	1/1/2" I.D. Trantorque
24	1	CWO-6110	Rotation Control
24	1	CWO-6110-240	Rotation Control
25	1	CWO-6116-K	Rotation Control Mounting Kit

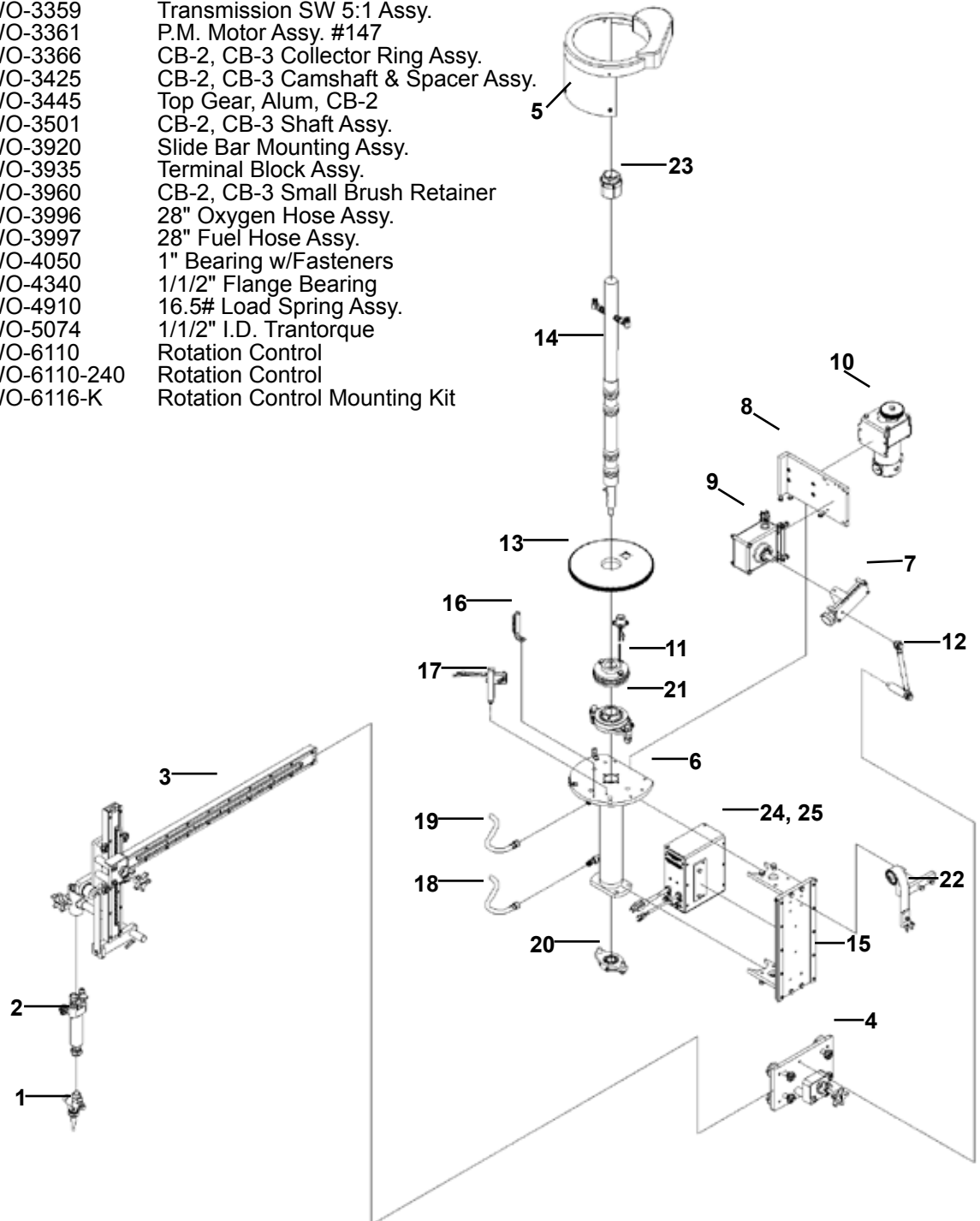

(CBO-3000) CB-3 CIRCLE BURNER / WIRING DIAGRAM

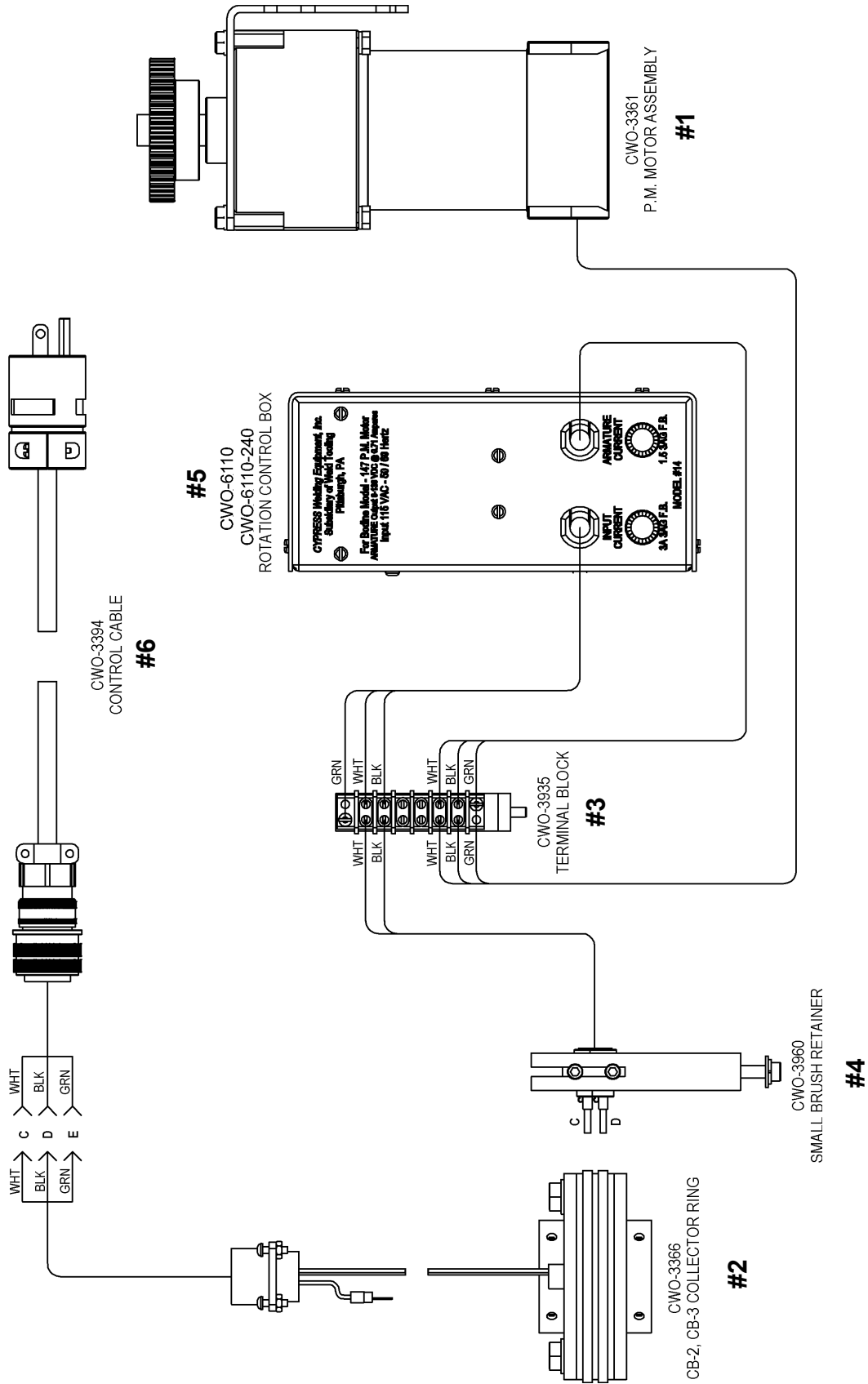

(CWO-1635) RACKING SYSTEM CB-2, CB-3 / EXPLODED VIEW / PARTS LIST

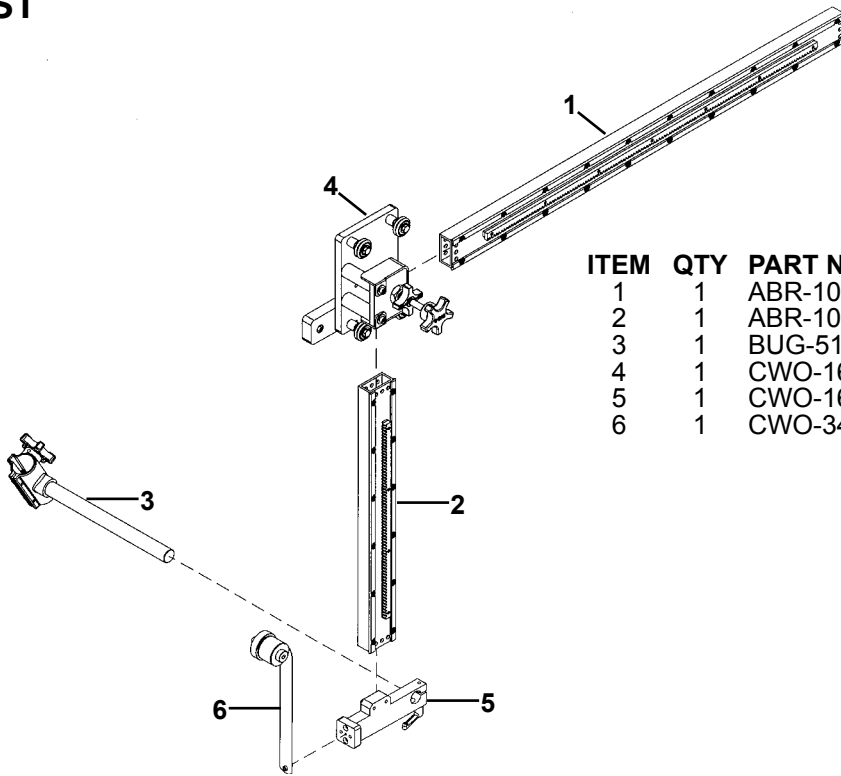

ITEM	QTY	PART NUMBER	DESCRIPTION
1	1	ABR-1060	V-Guide Ways 33"
2	1	ABR-1070	V-Guide Ways 19"
3	1	BUG-5188-10	Torch Holder Assy. w/10" Rod
4	1	CWO-1675	Vertical Racker
5	1	CWO-1695	Attachment Block
6	1	CWO-3450	10.6# Load Spring Assy.

(CWO-1690) LARGE HORIZONTAL RACKER / EXPLODED VIEW / PARTS LIST

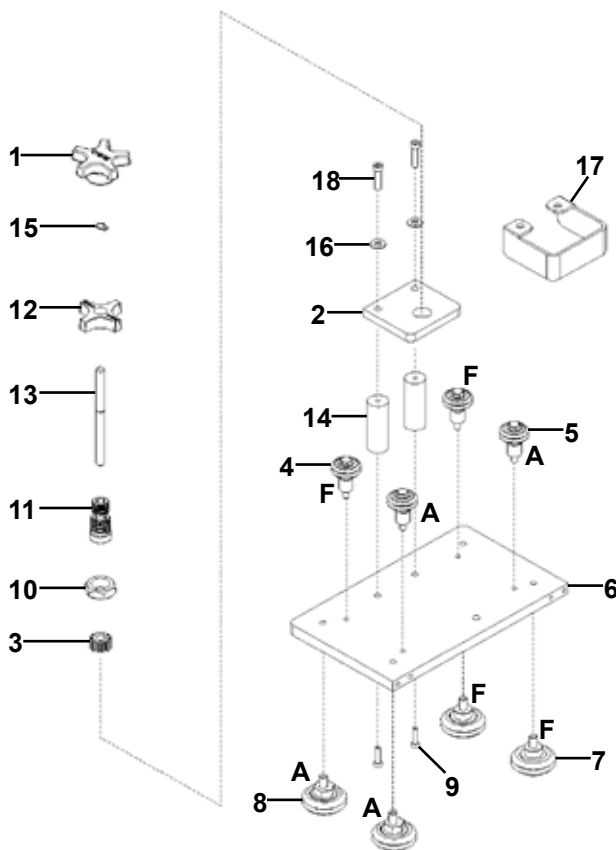

ITEM	QTY	PART NUMBER	DESCRIPTION
1	1	BUG-2032	Knob, Black
2	1	CWO-1678	Racker Plate
3	1	CWO-1679	Pinion 11T
4	2	CWO-1680	W2 Fixed Leg & Wheel Assy.
5	2	CWO-1681	W2 Adj. Leg & Wheel Assy.
6	1	CWO-1687	Mount Plate (Large Racker)
7	2	CWO-4326	Fixed Leg & Wheel Assy.
8	2	CWO-4326	Adj. Leg & Wheel Assy.
9	2	FAS-0557	Soc Hd Cap Scr 1/4-20 x 3/4"
10	1	FAS-1307	Hex Jam Nut 3/4-16
11	1	MUG-1141	Bearing Collet
12	1	MUG-1142	Knob, Locking
13	1	MUG-1144	Shaft
14	2	MUG-1453	Stand-Off
15	1	MUG-1579	Retaining Ring
16	3	WAS-0204	1/4" SAE Washer
17	1	CWO-1671	Racker Shield
18	2	FAS-0559	Soc Hd Cap Scr 1/4-20 x 1"

A = Adjustable Leg & Wheel Assembly

F = Fixed Leg & Wheel Assembly

(CWO-3193) CB-2, CB-3 HOUSING ASSEMBLY / EXPLODED VIEW / PARTS LIST

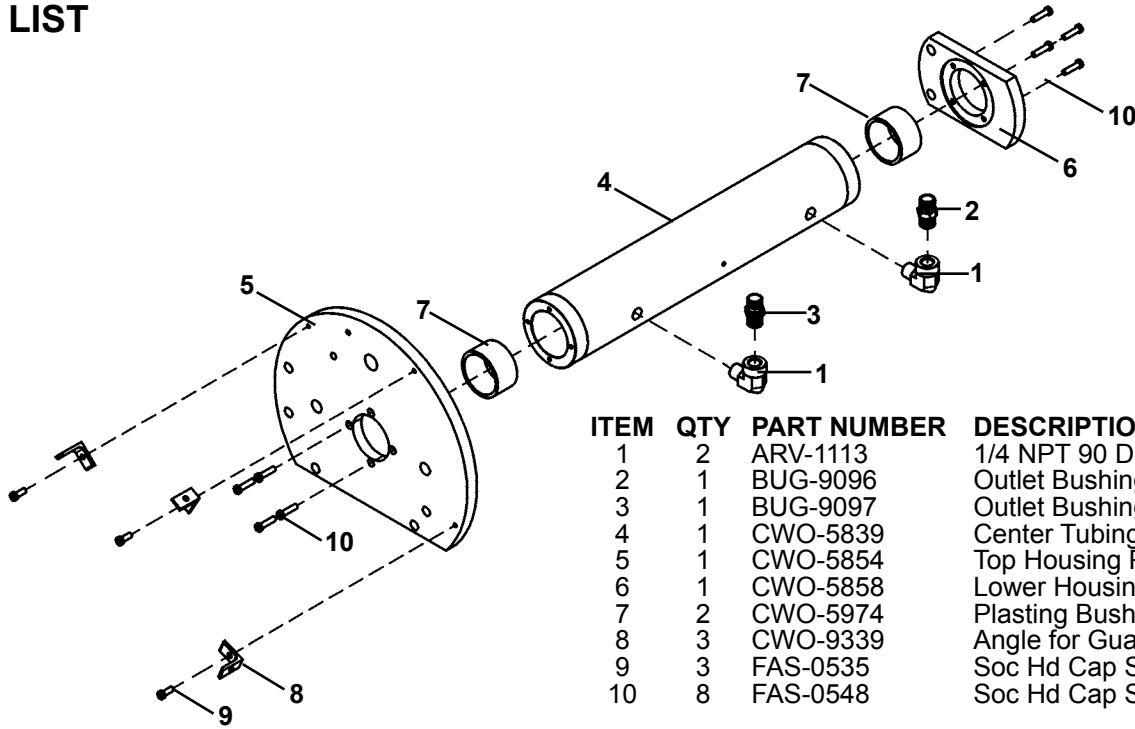

ITEM	QTY	PART NUMBER	DESCRIPTION
1	2	ARV-1113	1/4 NPT 90 Degree St. Elbow
2	1	BUG-9096	Outlet Bushing, Oxygen
3	1	BUG-9097	Outlet Bushing, Fuel Gas
4	1	CWO-5839	Center Tubing Housing CB-2
5	1	CWO-5854	Top Housing Plate CB-2
6	1	CWO-5858	Lower Housing Plate CB-2, CB-3
7	2	CWO-5974	Plasting Bushing
8	3	CWO-9339	Angle for Guard
9	3	FAS-0535	Soc Hd Cap Scr 10-24 x 1/2"
10	8	FAS-0548	Soc Hd Cap Scr 10-32 x 3/4"

(CWO-3205) 7" CAM ASSEMBLY / EXPLODED VIEW / PARTS LIST

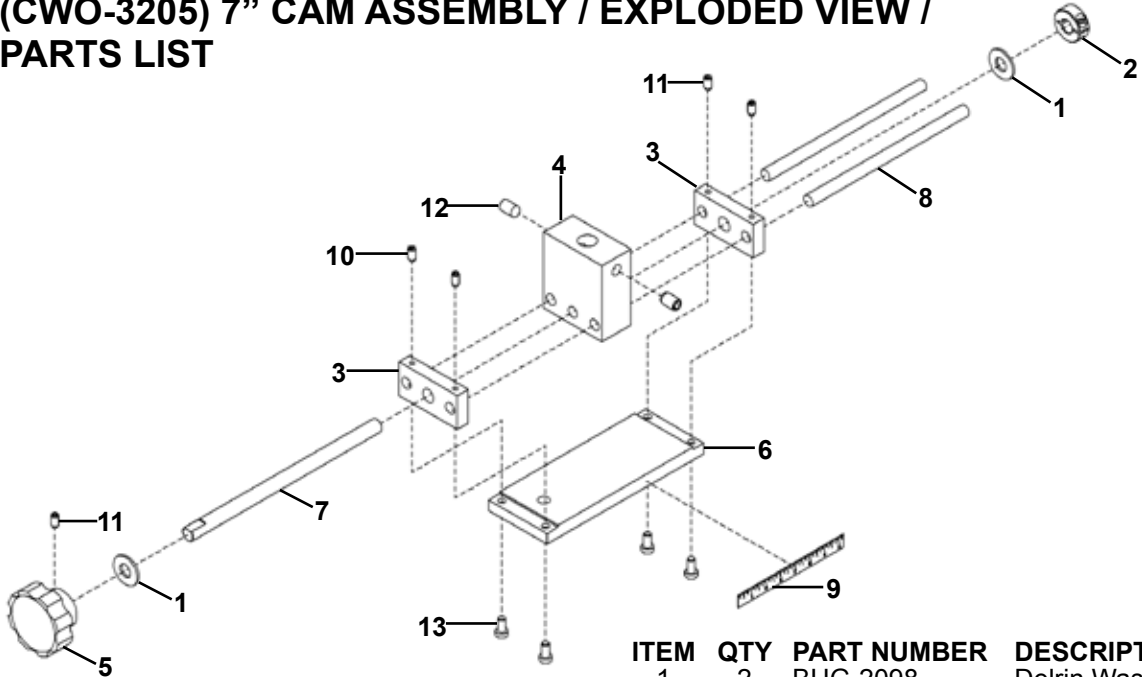

ITEM	QTY	PART NUMBER	DESCRIPTION
1	2	BUG-2098	Delrin Washer 3/8"
2	1	BUG-9012	Locking Collar
3	2	CWO-4027	End Plate 5" Cam
4	1	CWO-4028	Center Plate 5" Cam
5	1	CWO-4032	Knob
6	1	CWO-4328	Base Plate 7" Cam
7	1	CWO-4331	Screw 7" Cam
8	2	CWO-4332	Rod 7" Cam
9	1	CWO-5199	Scale
10	4	FAS-0434	Set Scr #10-24 x 3/8"
11	1	FAS-0444	Set Scr #10-32 x 3/8"
12	2	FAS-0495	Set Scr 3/8"-16 x 1/2"
13	4	FAS-0534	Soc Hd Cap Scr #10-24 x 3/8"

(CWO-3358) CB-2, CB-3 MOTOR & TRANSMISSION PLATE / EXPLODED VIEW / PARTS LIST

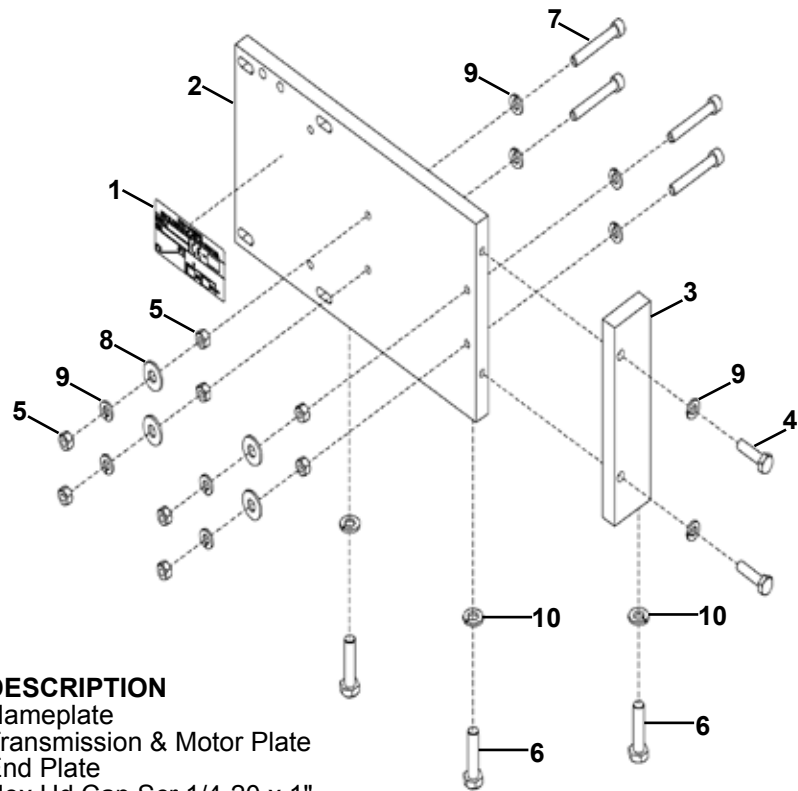

ITEM	QTY	PART NUMBER	DESCRIPTION
1	1	BUG-1338	Nameplate
2	1	CWO-5885	Transmission & Motor Plate
3	1	CWO-5886	End Plate
4	2	FAS-0359	Hex Hd Cap Scr 1/4-20 x 1"
5	8	FAS-1351	Hex Nut 1/4-20
6	3	FAS-2372	Hex Hd Cap Scr 5/16-18 x 1-1/4"
7	4	FAS-2554	Soc Hd Cap Scr 1/4-20 x 1-3/4"
8	4	WAS-0241	1/4" USS Zinc Flat Washer
9	10	WAS-0243	1/4" Split Lockwasher
10	3	WAS-0251	5/16" Split Lockwasher

(CWO-3359) TRANSMISSION SW 5:1 / EXPLODED VIEW / PARTS LIST

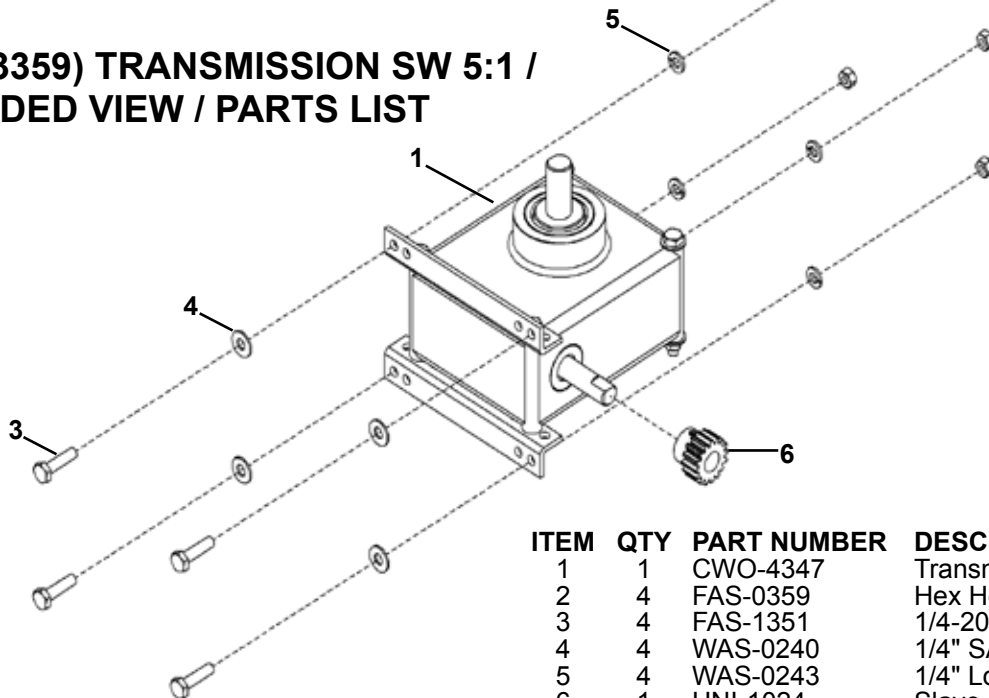

ITEM	QTY	PART NUMBER	DESCRIPTION
1	1	CWO-4347	Transmission 5:1
2	4	FAS-0359	Hex Hd Cap Scr 1/4-20 x 1"
3	4	FAS-1351	1/4-20 Hex Nut
4	4	WAS-0240	1/4" SAE Washer
5	4	WAS-0243	1/4" Lock Washer
6	1	UNI-1024	Slave Pinion

(CWO-3361) P.M. MOTOR ASSEMBLY #147 / EXPLODED VIEW / PARTS LIST

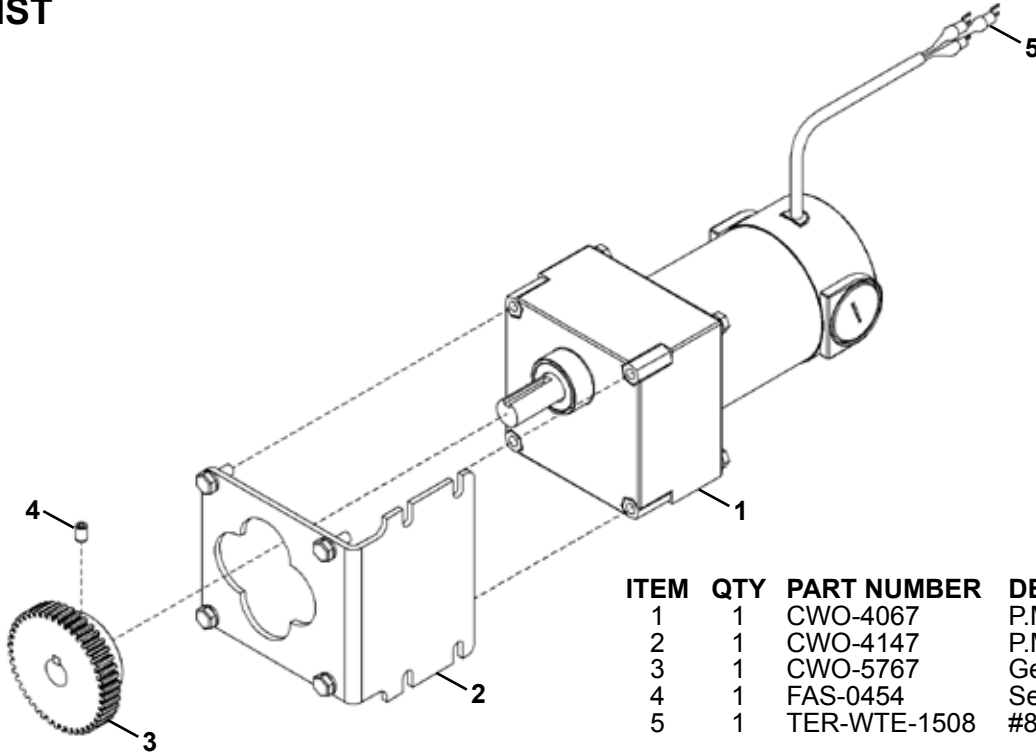

ITEM	QTY	PART NUMBER	DESCRIPTION
1	1	CWO-4067	P.M. Motor #147
2	1	CWO-4147	P.M. Motor Bracket #970
3	1	CWO-5767	Gear, P.M. Motor #147
4	1	FAS-0454	Set Scr 1/4-20 x 3/8"
5	1	TER-WTE-1508	#8 Fork Blue 14RB-8FL-T&B

(CWO-3425) CB-2, CB-3 CAMSHAFT & SPACER ASSEMBLY / EXPLODED VIEW / PARTS LIST

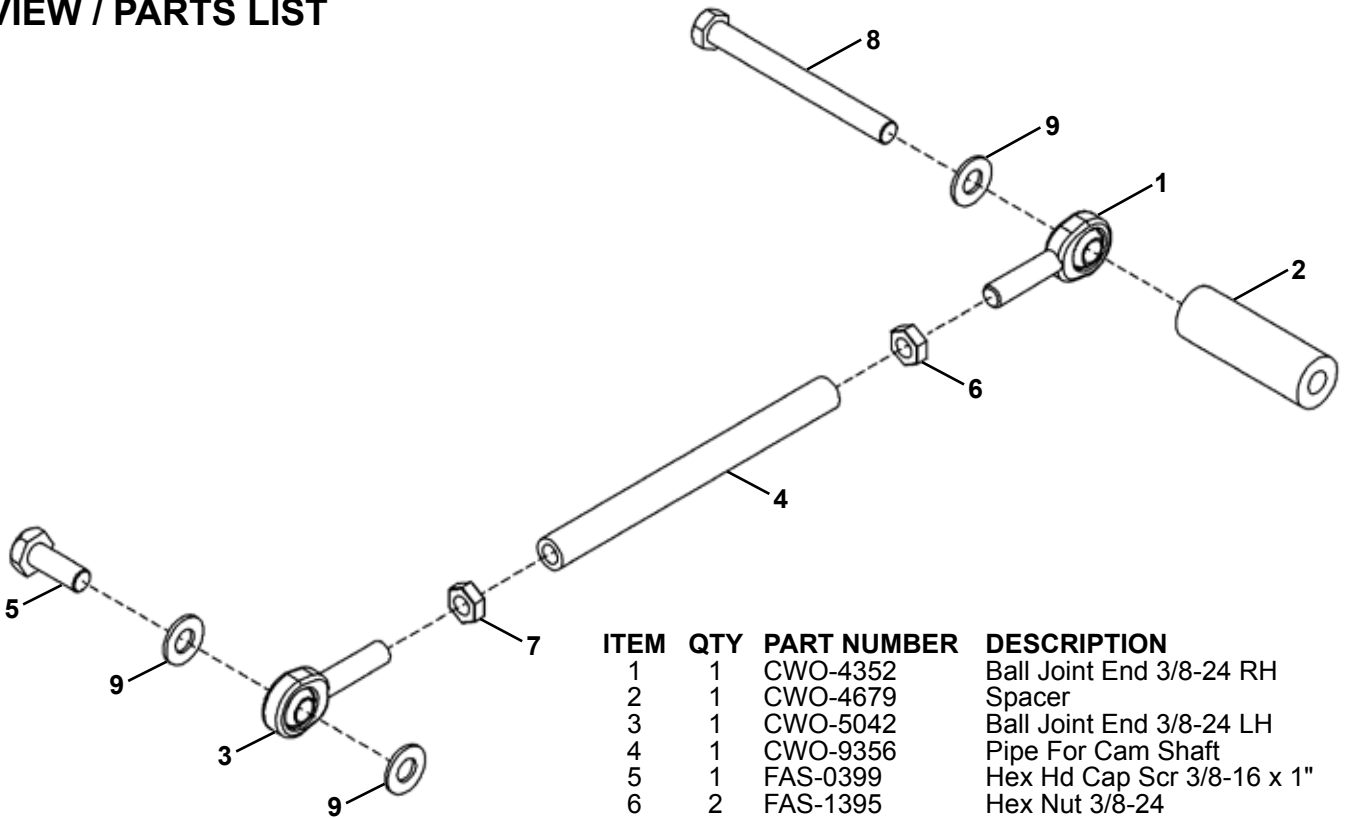

ITEM	QTY	PART NUMBER	DESCRIPTION
1	1	CWO-4352	Ball Joint End 3/8-24 RH
2	1	CWO-4679	Spacer
3	1	CWO-5042	Ball Joint End 3/8-24 LH
4	1	CWO-9356	Pipe For Cam Shaft
5	1	FAS-0399	Hex Hd Cap Scr 3/8-16 x 1"
6	2	FAS-1395	Hex Nut 3/8-24
7	1	FAS-1396	Hex Nut 3/8-24 Left Handed
8	1	FAS-2401	Hex Hd Cap Scr 3/8-16 x 3-3/4"
9	3	WAS-0260	3/8" SAE Washer

(CWO-3501) CB-2, CB-3 SHAFT ASSEMBLY / EXPLODED VIEW / PARTS LIST

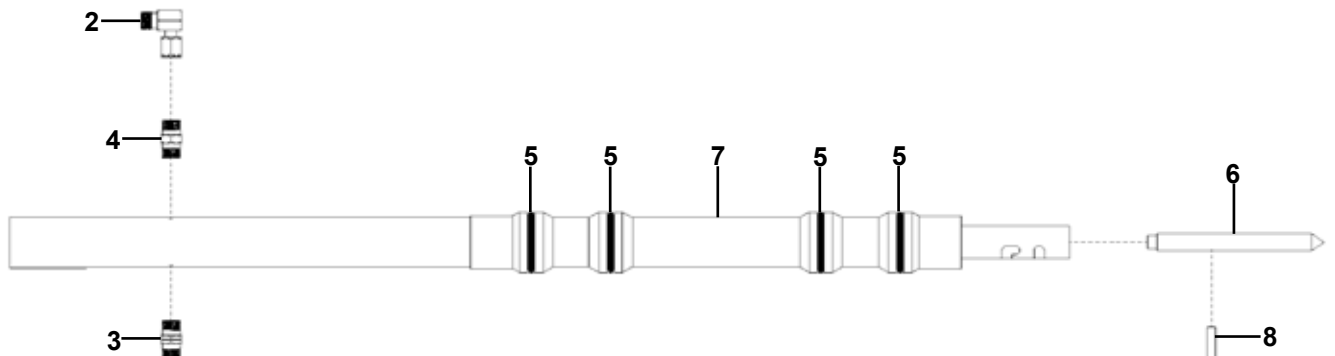

ITEM	QTY	PART NUMBER	DESCRIPTION
1	1	BUG-1296	90° Hose Adaptor, Oxygen
2	1	BUG-1297	90° Hose Adaptor, Fuel
3	1	BUG-9096	Outlet Bushing, Oxygen
4	1	BUG-9097	Outlet Bushing, Fuel
5	4	CWO-4049	O-Ring, Oxygen, Fuel
6	1	CWO-3502	CB-1P, CB-2 Pointer
7	1	CWO-5577	CB-2, CB-3 Shaft
8	1	FAS-0539	Soc Hd Cap Scr 10-24 x 1"

(CWO-3920) SLIDE BAR MOUNTING ASSEMBLY / EXPLODED VIEW / PARTS LIST

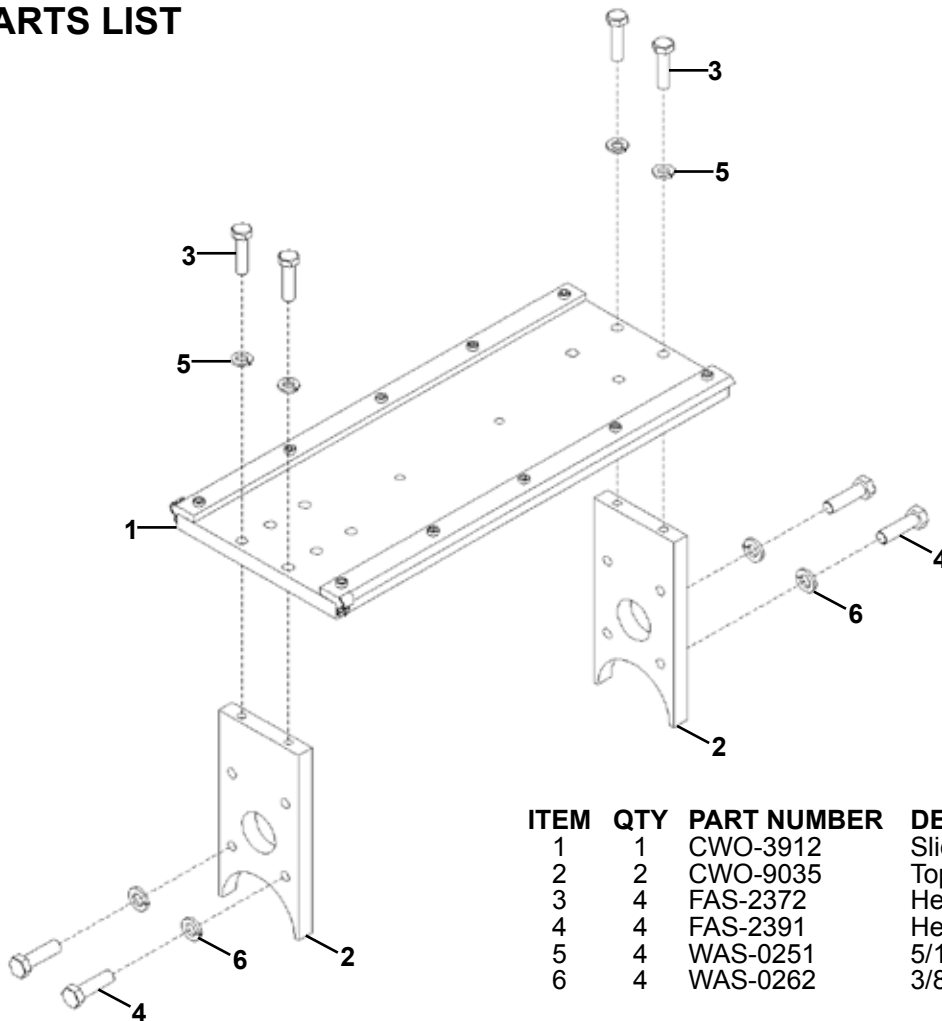

ITEM	QTY	PART NUMBER	DESCRIPTION
1	1	CWO-3912	Slide Bar Assy.
2	2	CWO-9035	Top/Bottom Vert Slide Plate
3	4	FAS-2372	Hex Hd Cap Scr 5/16-18 x 1-1/4"
4	4	FAS-2391	Hex Hd Cap Scr 3/8-16 x 1-1/4"
5	4	WAS-0251	5/16" Split Lock Washer
6	4	WAS-0262	3/8" Split Lock Washer

(CWO-3960) CB-2, CB-3 SMALL BRUSH ASSEMBLY / EXPLODED VIEW / PARTS LIST

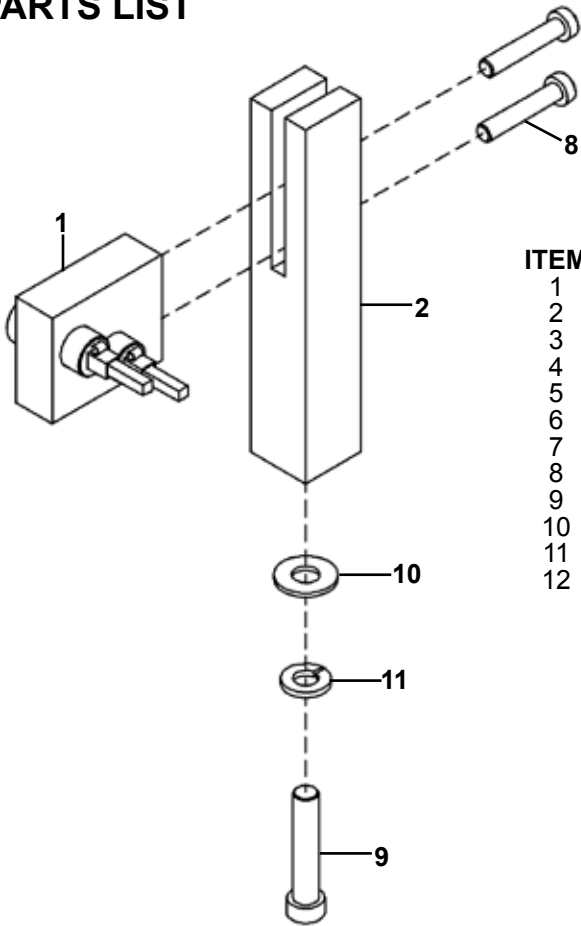

ITEM	QTY	PART NUMBER	DESCRIPTION
1	1	CWO-3961	CB-2 Small Retainer Block
2	1	CWO-9076	Small Retainer Support
3	2	CWO-5831	1/8" x 1/8" x 7/8" Brush
4	2	CWO-5874	1/8" Brush Holder
5	2	CWO-5875	Cap
6	2	CWO-5876	Clip
7	1	CWO-9108	CB-2 Small Brush Block
8	2	FAS-0539	Soc Hd Cap Scr 10-24 x 1"
9	1	FAS-2551	Soc Hd Cap Scr 1/4-20 x 1-1/4"
10	1	WAS-0240	1/4" SAE Washer
11	1	WAS-0243	1/4" Split Lock Washer
12	2	TERM WTE-0602	#6 Fork Blue

(CWO-3961) CB-2. CB-3 SMALL RETAINER BLOCK / DETAIL VIEW

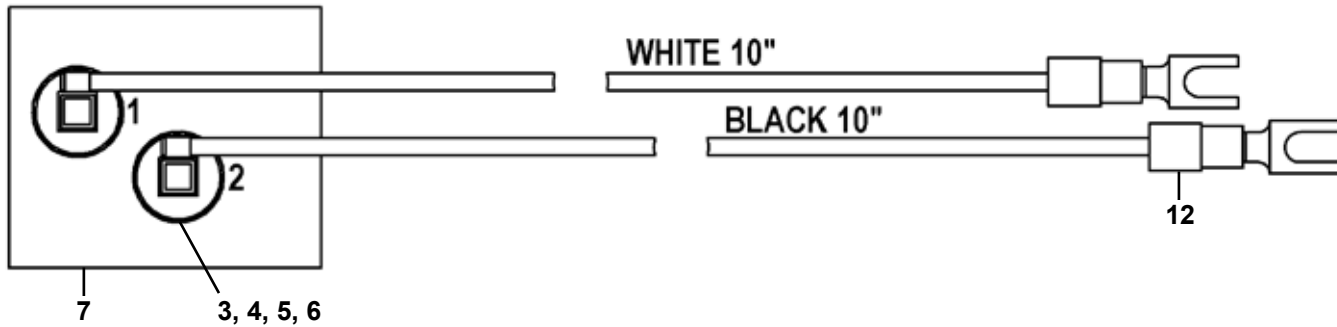

(CWO-6110) ROTATION CONTROL / EXPLODED VIEW / PARTS LIST

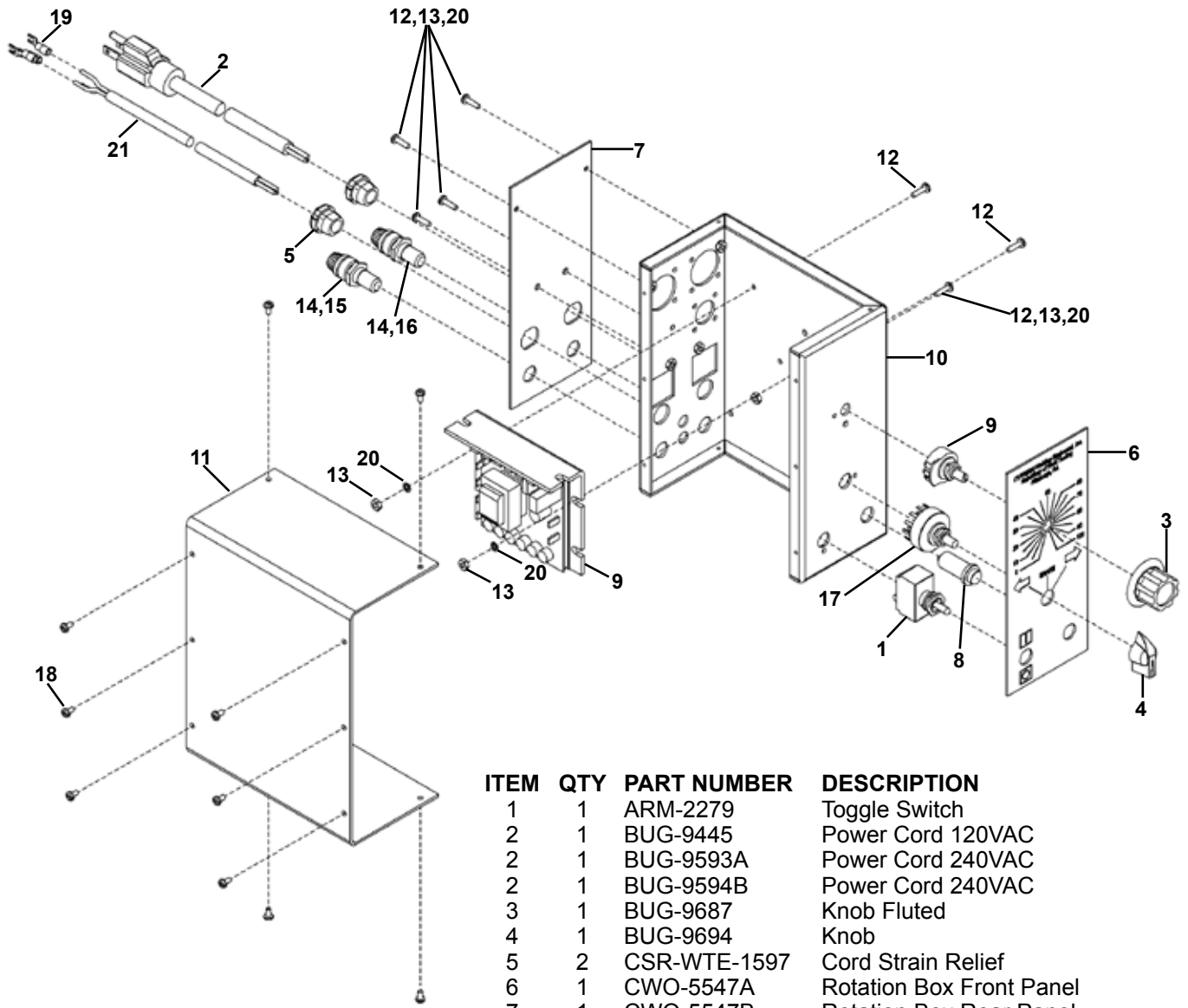

ITEM	QTY	PART NUMBER	DESCRIPTION
1	1	ARM-2279	Toggle Switch
2	1	BUG-9445	Power Cord 120VAC
2	1	BUG-9593A	Power Cord 240VAC
2	1	BUG-9594B	Power Cord 240VAC
3	1	BUG-9687	Knob Fluted
4	1	BUG-9694	Knob
5	2	CSR-WTE-1597	Cord Strain Relief
6	1	CWO-5547A	Rotation Box Front Panel
7	1	CWO-5547B	Rotation Box Rear Panel
7	1	CWO-5547C	Rotation Box Rear Panel 240VAC
8	1	CWO-6206	Indicator Light 120 VAC
8	1	BUG-1428	Indicator Light 240 VAC
9	1	CWO-6525	MTR Control Board w/Pot
10	1	CWO-6801	Rotation Control Case
11	1	CWO-6802	Rotation Box Cover
12	7	FAS-0115	#6-32 x 1/2" Pan Head Zinc
13	7	FAS-1310	Hex Nut 6-32
14	2	FHO-0188	Fuse Holder
15	1	FUS-0190	Fuse 1.5 Amp
16	1	FUS-0257	Fuse 3 Amp
17	1	MUG-1258-1	Rotary Switch Assembly
18	10	SCW-WTE-0264	#6-32 x 1/4" Sht Mt Scr
19	3	TERM-WTE-0439	#10 20 AWG Connector
20	7	WAS-0211	#6 Internal Star Washer
21	42"	WRE-WTE-0501	18/3 SJO 300V Cord
22	1	CWO-6524	Pot

(CWO-6110) ROTATION CONTROL / WIRING DIAGRAM

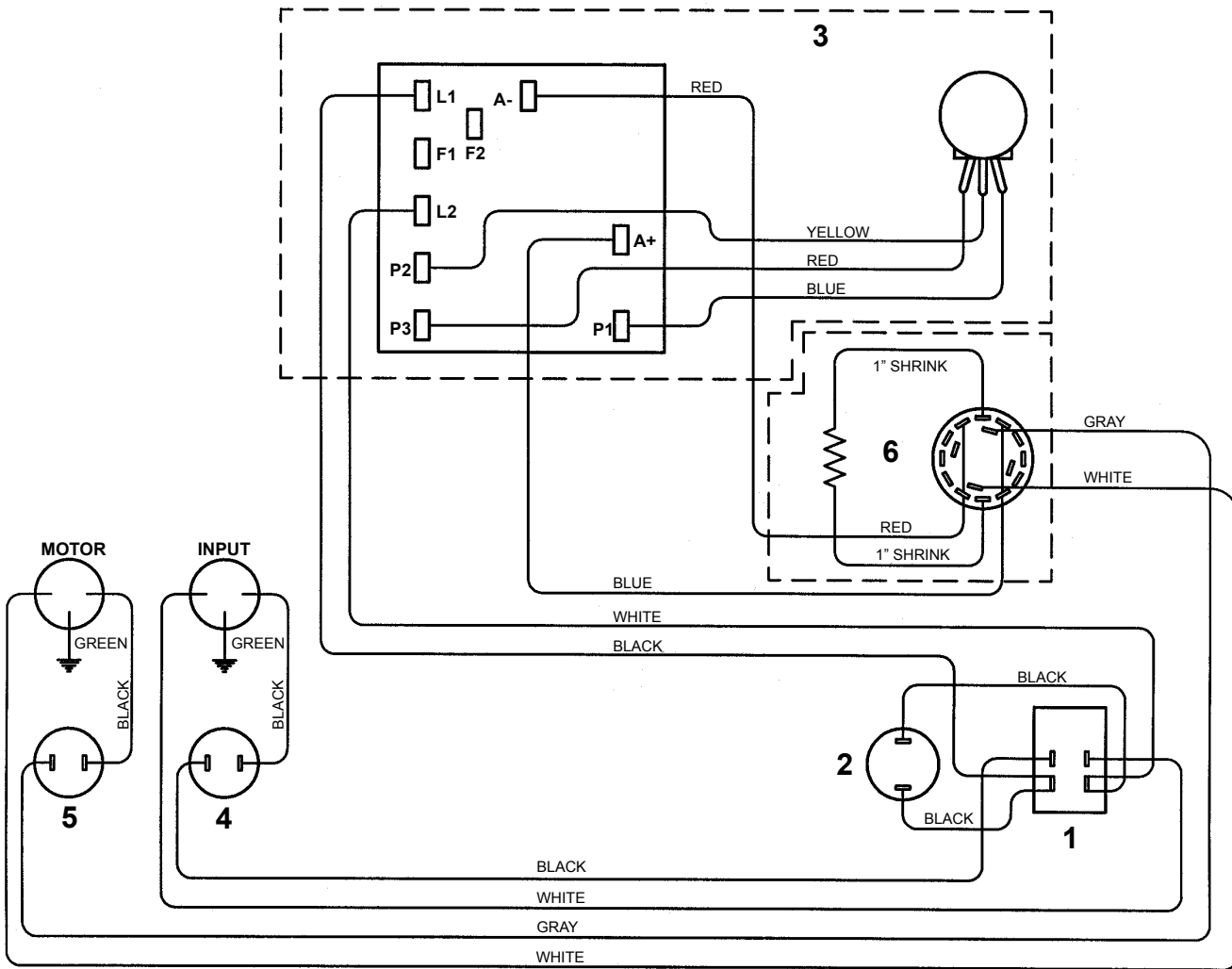

--- = INDICATES ITEMS THAT ARE SUPPLIED TOGETHER.

ELECTRICAL COMPONENT CHART

ITEM	DESCRIPTION	PART NUMBER
1	Toggle Switch	ARM-2279
2	Red Neon Lamp	CWO-6206 120V BUG-1428 240V
3	Speed Control Board w/Resistor	CWO-6525
4	Fuse 1.5 amp	FUS-0190
5	Fuse 3 amp	FUS-0257
6	Rotary Switch	MUG-1258-1

(CWO-3073) CB-2 FRAME / EXPLODED VIEW / PARTS LIST

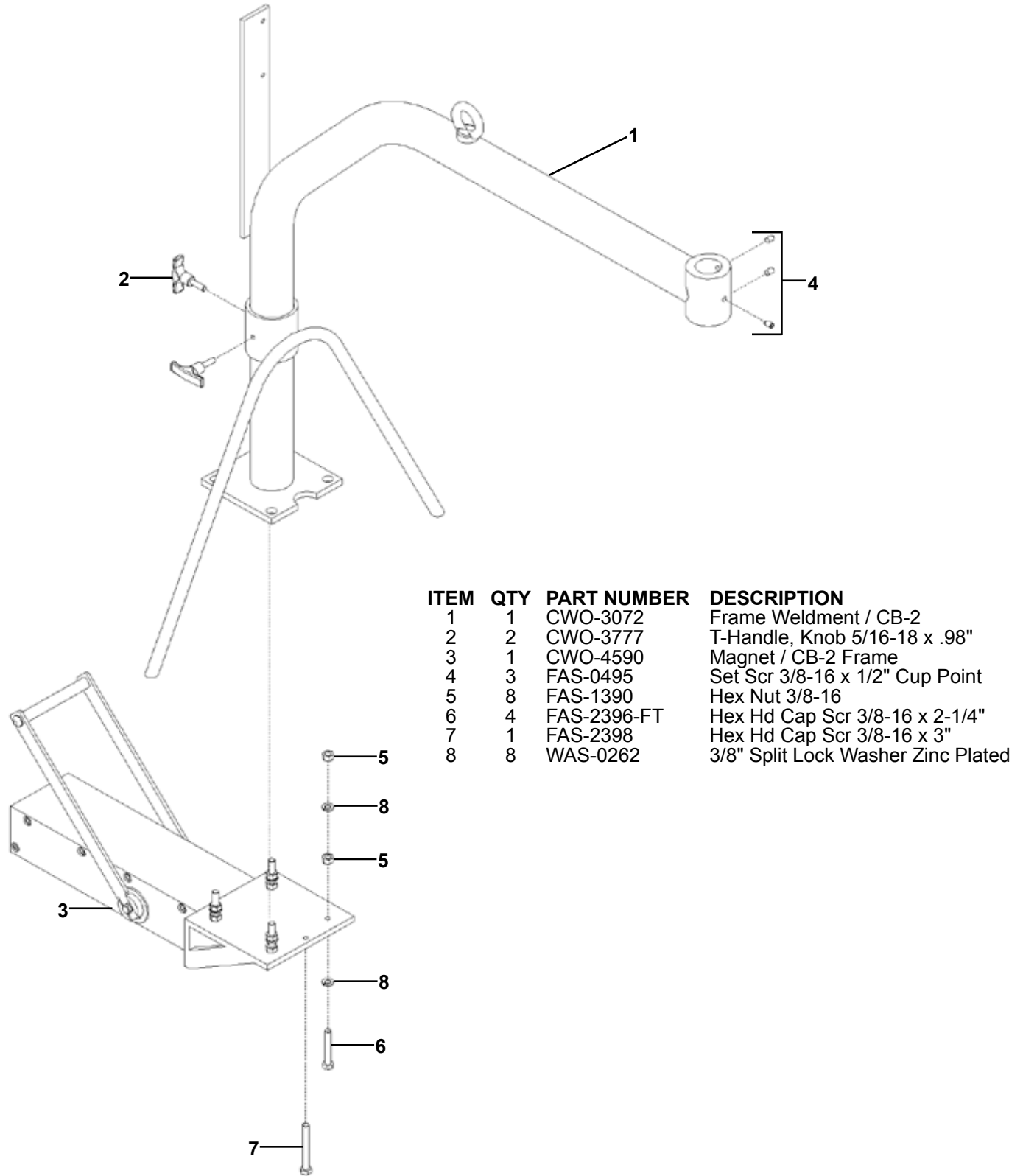

ITEM	QTY	PART NUMBER	DESCRIPTION
1	1	CWO-3072	Frame Weldment / CB-2
2	2	CWO-3777	T-Handle, Knob 5/16-18 x .98"
3	1	CWO-4590	Magnet / CB-2 Frame
4	3	FAS-0495	Set Scr 3/8-16 x 1/2" Cup Point
5	8	FAS-1390	Hex Nut 3/8-16
6	4	FAS-2396-FT	Hex Hd Cap Scr 3/8-16 x 2-1/4"
7	1	FAS-2398	Hex Hd Cap Scr 3/8-16 x 3"
8	8	WAS-0262	3/8" Split Lock Washer Zinc Plated

ACCESSORIES:

CWO-3744 Manipulator Bracket

The Manipulator Bracket is a mounting device that was designed to be used on some Circle Welders and Circle Burners. It attaches to an existing fixture and can be easily adjusted to make sure that the Circle Welder/Burner remains square on the work piece.

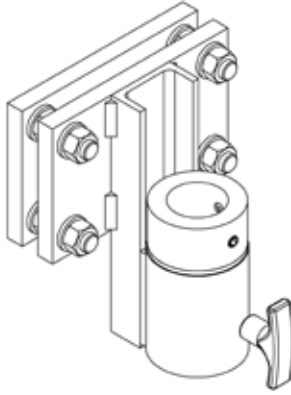

CWO-3895 Hillside Kit

The CWO-3895 Hillside Kit provides a *single* rise and fall motion per revolution of the machine to provide the motion required to follow the contour of an *offset* pipe-to-pipe weld.

During standard operation, the cam mechanism of all Cypress Welders provides a *dual* rise and fall action per revolution to follow the contour of a pipe-to-pipe weld. Once the Hillside Kit is installed on a Cypress circle welder, the operator can easily engage or disengage it to switch between single or dual rise and fall operation.

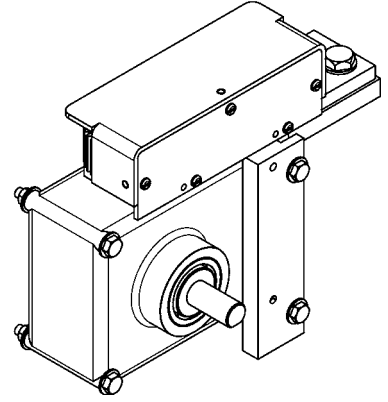

(CWO-3744) MANIPULATOR BRACKET / EXPLODED VIEW / PARTS LIST

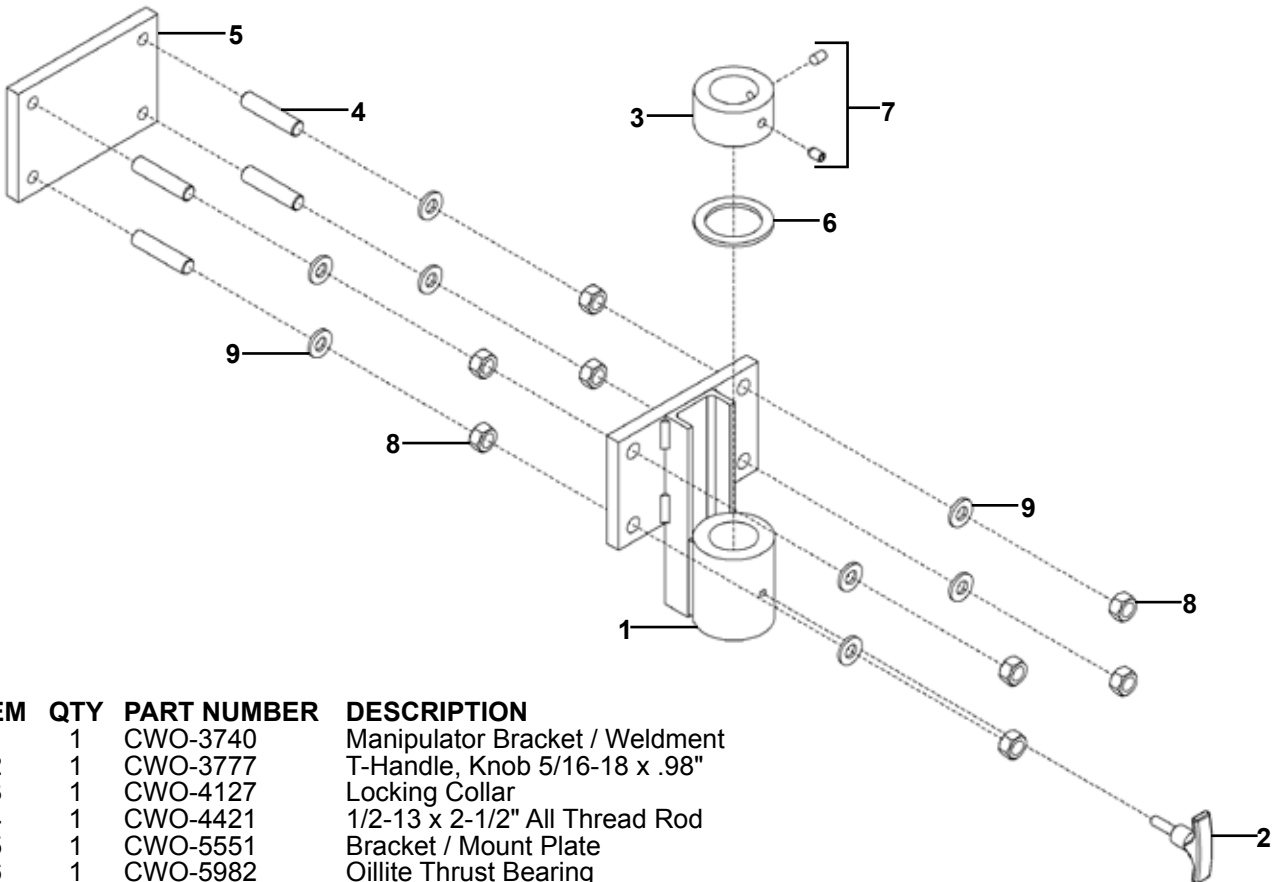

ITEM	QTY	PART NUMBER	DESCRIPTION
1	1	CWO-3740	Manipulator Bracket / Weldment
2	1	CWO-3777	T-Handle, Knob 5/16-18 x .98"
3	1	CWO-4127	Locking Collar
4	1	CWO-4421	1/2-13 x 2-1/2" All Thread Rod
5	1	CWO-5551	Bracket / Mount Plate
6	1	CWO-5982	Oillite Thrust Bearing
7	2	FAS-0495	Set Scr 3/8-16 x 1/2"
8	8	FAS-1301	Hex Nut 1/2-13
9	12	WAS-0280	1/2" Washer

PREVENTIVE MAINTENANCE / CB-2, CB-3 CIRCLE BURNER

CAUTION: Make sure the input power (110v) from the Rotation Control is disconnected from the power source.

AFTER DAILY USE:

Refer to CB-2, CB-3 Exploded View Parts List. (CB-2 page 11; CB-3 page 13)

Racking System (Item #3): Inspect gear rack; hardened ways and wheels remove all dirt, grease, and rust. Check hardened ways for nicks and replace if necessary. Lubricate with a dry spray lubricant. Adjust wheels for snug fit and smooth operation. Lubricate racker pinion with a dry teflon or graphite spray lubricant.

Large Vertical Racker (Item #4): Inspect wheels and remove all dirt, grease, and rust. Adjust wheels for snug fit and smooth operation. Lubricate racker pinion and wheels with a dry Teflon or graphite spray lubricant.

Slide Bar Mounting Assembly (Item #15): Inspect hardened ways remove all dirt, grease, and rust. Check hardened ways for nicks and replace if necessary. Lubricate the hardened ways with a dry Teflon or graphite spray lubricant.

Refer to CB-2, CB-3 Electrical Wiring Diagram. (CB-2 page 12; CB-3 page 14)

CB-2, CB-3 Collector Ring (Item #2): Inspect cable connections for damages and that the connector is not cracked. Ensure that the connector is fastened properly to the Top Aluminum Gear (Item #13) on the CB-2, CB-3 Exploded View Parts List.

EVERY SIX MONTHS:

Refer to CB-2, CB-3 Exploded View Parts List. (CB-2 page 11; CB-3 page 13)

Top Aluminum Gear (Item # 13): Do not grease this gear. Inspect gear teeth remove all dirt, grease, and rust. Lubricate with a dry Teflon or graphite spray lubricant. Replace gear if excessively worn.

P.M. Motor Assembly (Item #10): Do not grease this pinion. Inspect the drive pinion remove all dirt, grease, and rust. Lubricate with a dry Teflon or graphite spray lubricant. Replace pinion if excessively worn. Check set screw and tighten if necessary. Adjust motor assembly using the four adjustable mounting fasteners so that proper gear mesh is achieved between the Top Aluminum Gear (Item # 15) and the motor drive pinion.

7" Cam Assembly (Item # 7): Inspect the slide rails and the cam pinion. Remove all dirt, grease, and rust. Do not grease slide rails or cam pinion. Lubricate with a dry Teflon or graphite spray lubricant. Replace cam pinion if excessively worn. Tighten all fasteners as needed.

PREVENTIVE MAINTENANCE / CB-2, CB-3 CIRCLE BURNER

Refer to CB-2, CB-3 Electrical Component Chart. (CB-2 page 12; CB-3 page 14)

M-14 Rotation Control (Item #5): Open control box use an air hose to blow out dust and dirt. Check all wires for breaks and replace if necessary. Check all electrical connectors and plugs if an electrical component fails refer to CWO-6110 Rotation Control electrical component chart for replacement parts or return for service.

Small Brush Retainer Assembly (Item #4): Inspect black brush holders for cracks and replace if needed. Check and make sure all wires are soldered properly to the holders. Replace the brushes when their length is less than ½ inch long. Remove the brushes and sand them to ensure a smooth contact surface. Make sure all fasteners are tight.

Terminal Block (Item #3): Inspect the plastic terminal strip make sure it is not cracked, replace if necessary. Make sure all terminal connections are tight. Make sure all ground wires are connected to the mounting screws of the terminal strip.

EVERY TWELVE MONTHS:

Refer to CB-2, CB-3 Exploded View Parts List. (CB-2 page 11; CB-3 page 13)

1" Bearing with Fasteners (Item #20): Do not grease the bearing it is greased for life by the manufacturer. If the grease fitting has not been removed and plugged we suggest that you do so now. Earlier models may not have been plugged at time of assembly.

1-1/2" Bearing with Fasteners (Item # 21): Do not grease the bearing it is greased for life by the manufacturer. If the grease fitting has not been removed and plugged we suggest that you do so now. Earlier models may not have been plugged at time of assembly.

P.M. Motor Assembly (Item #10): Bodine gear motor lubrication. Fill gear motor to oil level indicator with worm gear oil conforming to AGMA#5EP compounded (SAE#90) oil or Bodine lubricant #LO-23. Do not overfill.

Transmission 5:1 Assembly (Item #9): Inspect for excessive wear and tear. Keep the transmission assembly clean and lubricate with Lubriplate #630-AA.

Refer to CB-2 CB-3 Electrical Component Chart. (CB-2 page; CB-3 page 14)

CB-1P Collector (Item # 2): The collector ring should be sanded once a year. If the collector ring is pitted too badly it should be replaced. Inspect all wires coming out of the collector ring for cut or missing insulation. All wires should be fastened to the center shaft with a nylon cable tie. Tighten four set screws if needed.

WARRANTY

Limited 3-Year Warranty

Model _____
Serial No. _____
Date Purchased: _____
Where Purchased: _____

For a period ending one (1) year from the date of invoice, Manufacturer warrants that any new machine or part is free from defects in materials and workmanship and Manufacturer agrees to repair or replace at its option, any defective part or machine. HOWEVER, if the invoiced customer registers the Product Warranty by returning the Warranty Registration Card supplied with the product within 90 days of the invoice date, or by registering on-line at www.bugo.com, Manufacturer will extend the warranty period an additional two (2) years which will provide three (3) total years from the date of original invoice to customer. This warranty does not apply to machines which, after Manufacturer's inspection are determined by Manufacturer to have been damaged due to neglect, abuse, overloading, accident or improper usage. All shipping and handling charges will be paid by the customer.

The foregoing express warranty is exclusive and Manufacturer makes no representation or warranty (either express or implied) other than as set forth expressly in the preceding sentence. Specifically, Manufacturer makes no express or implied warranty of merchantability or fitness for any particular purpose with respect to any goods. Manufacturer shall not be subject to any other obligations or liabilities whatsoever with respect to machines or parts furnished by Manufacturer.

Manufacturer shall not in any event be liable to Distributor or any customer for any loss of profits, incidental or consequential damages or special damages of any kind. Distributor's or customer's sole and exclusive remedy against Manufacturer for any breach of warranty, negligence, strict liability or any other claim relating to goods delivered pursuant hereto shall be for repair or replacement (at Manufacturer's option) of the machines or parts affected by such breach.

Distributor's Warranty:

In no event shall Manufacturer be liable to Distributor or to any customer thereof for any warranties, representations or promises, express or implied, extended by Distributor without the advance written consent of Manufacturer, including but not limited to any and all warranties of merchantability or fitness for a particular purpose and all warranties, representations or promises which exceed or are different from the express limited warranty set forth above. Distributor agrees to indemnify and hold Manufacturer harmless from any claim by a customer based upon any express or implied warranty by Distributor which exceeds or differs from Manufacturer's express limited warranty set forth above.

HOW TO OBTAIN SERVICE:

If you think this machine is not operating properly, re-read the instruction manual carefully, then call your Authorized BUG-O dealer/distributor. If they cannot give you the necessary service, write or phone us to tell us exactly what difficulty you have experienced. BE SURE to mention the MODEL and SERIAL numbers.